

User Manual

M3000[®] Automation System

MSC II (Moog Servo Controller)

CONTROL MODULE FOR DIN TOP-HAT RAIL MOUNTING

Copyright

© 2008 Moog GmbH
Hanns-Klemm-Strasse 28
71034 Böblingen (Germany)
Telephone: +49 7031 622-0
Fax: +49 7031 622-100
E-Mail: Info.germany@moog.com
M3000-Support@moog.com
Internet: <http://www.moog.com/industrial>

All rights reserved.

Neither this manual nor parts of it may be reproduced in any form (print, photocopy, microfilm, or any other process) or processed, duplicated, or distributed through the use of electronic systems without Moog's written approval.

Offenders will be held liable for the payment of damages.

Subject to changes without prior notice.

 All M3000® modules comply with the standards specified in their relevant declaration of conformity. CE labeling of the M3000® modules is based on proper installation of the automation system with proven electromagnetic compatibility (EMC).

Table of Contents

List of Tables	vi
List of Figures	viii
1 General Information	1
1.1 About this Manual	1
1.1.1 Reservation of Changes and Validity	1
1.1.2 Exclusion of Liability	1
1.1.3 Completeness	1
1.1.4 Place of Storage.....	1
1.2 Selection and Qualification of Personnel.....	2
1.3 Proper Use	2
1.3.1 Safety Related Systems	2
1.4 Warranty and Liability	3
1.5 Inspection of Delivery	3
1.6 Environmental Protection	4
1.6.1 Emissions	4
1.6.2 Disposal.....	4
1.7 Standards	4
1.7.1 CE Labeling of M3000® Modules	4
1.7.2 IEC 61131-2	4
1.7.3 Electromagnetic Compatibility (EMC).....	4
1.8 Trademarks	5
1.9 Software Copyrights	5
2 Safety Instructions	6
2.1 Typographical Conventions	6
2.2 Safety Instructions	6
2.2.1 Safety Related Systems	6
2.2.2 Environmental Conditions	7
2.2.3 ESD	7
2.2.4 Project Planning and Installation	8
2.2.5 Shutdown and Service	9
2.2.6 Transportation and Storage.....	10
2.2.7 Communication Between MSC II and MACS	11
2.2.8 License Key of the MSC II.....	11
2.2.9 Run/Stop/Reset.....	12
2.2.10 Switching Back on or Resetting the MSC II.....	12
2.2.11 'Outputs Enabled' Output of the MSC II	12
3 Short M3000® System Overview	13
3.1 M3000® System Architecture.....	14
3.2 MSC II Starter Kit	15
3.3 M3000® Modules	16
3.3.1 MSC I	16
3.3.2 MSC II	17
3.3.3 Q-Modules.....	17
3.3.4 R-Modules (Remote Modules)	19
3.3.5 MSD Motion Controller	22
3.3.6 MSD Servodrive	23
3.3.7 Identification	23

3.4 License Key	24
3.5 Application Programs	25
3.6 MACS Development Environment	25
3.6.1 MACS HMI Visualization Package	26
4 Environmental Conditions	27
4.1 Requirements of IEC 61131-2	27
4.2 Use in Special Environments	28
5 Mechanical Installation	29
5.1 DIN Rail Modules	29
5.1.1 Views of the Module	29
5.1.2 Dimensions.....	30
5.1.3 Arrangement on DIN Top-Hat Rails	31
5.1.4 Mounting and Removing	33
6 Project Planning and Installation	37
6.1 Grounding Concept.....	38
6.1.1 Front Panel Connectors' Grounding.....	38
6.2 Power Supply.....	39
6.2.1 Power Supply Characteristics	39
6.2.2 Power Consumption	40
6.2.3 Connecting the Power Supply	40
6.2.4 Connecting Sensors	43
6.3 Connecting Signal Cables	46
6.3.1 Plug-In Terminal Strips.....	46
7 Networking M3000[®] Modules	47
7.1 Ethernet.....	47
7.1.1 Peer-to-Peer Connections.....	47
7.1.2 Networking of More Than 2 Network Stations.....	48
7.1.3 Ethernet Interface Cables.....	48
7.2 EtherCAT	49
7.2.1 Bus Topology	49
7.2.2 EtherCAT Interface Cables	49
7.3 Profibus	50
7.3.1 Overview	50
7.3.2 M3000 [®] Modules with Profibus DP Interfaces	50
7.3.3 Profibus Networks	50
7.3.4 Profibus Interface Cable.....	52
7.4 Serial TIA/EIA Interface Cables	54
7.4.1 TIA/EIA 232 Interface Cables.....	54
7.5 CAN Bus and CANopen	55
7.5.1 CAN Bus.....	55
7.5.2 CAN Bus Characteristics.....	55
7.5.3 CANopen.....	56
7.5.4 M3000 [®] Modules with CAN Bus Interfaces.....	56
7.5.5 CAN Bus Networks.....	57
7.5.6 CAN Bus Interface Cable	59

7.6 E-Bus	60
7.6.1 E-Bus Interface.....	60
7.6.2 E-Bus Communication.....	61
7.6.3 MSC II as E-Bus Master.....	61
7.7 Networking DIN Rail Modules	64
7.7.1 CAN and E-Bus Interfaces	64
7.7.2 E-Bus Groups.....	65
7.7.3 LocalCAN Bus Groups	66
7.7.4 WideCAN Bus Groups.....	67
8 Shutdown and Service	69
8.1 Shutdown	69
8.2 Service	70
8.2.1 Maintenance/Serviceing	70
8.2.2 Repair.....	70
9 Transportation and Storage	71
9.1 Environmental Conditions	71
10 MSC II (Moog Servo Controller)	72
10.1 Performance Characteristics	72
10.1.1 Interfaces.....	72
10.1.2 I/Os (Inputs/Outputs).....	73
10.1.3 Safety Functions.....	73
10.2 General Specifications	73
10.2.1 Dimensions.....	74
10.2.2 Environmental Conditions	74
10.3 Block Diagram	76
10.4 View of the Module and Terminal Assignment	77
10.4.1 Terminal Assignment.....	78
10.4.2 LEDs.....	81
10.5 Programming and Configuration	84
10.5.1 Communication Between MSC II and MACS	84
10.6 License Key	85
10.6.1 Run-Time License and Accessible Libraries	85
10.6.2 CANopen Node-ID and IP Address.....	86
10.6.3 Mounting and Removing	86
10.7 Run/Stop/Reset Switch	88
10.8 Power Supply	89
10.8.1 Behavior at Switching on and Switching off	89
10.9 Basetick	90
10.9.1 Characteristics.....	90
10.9.2 Timing Diagram	91
10.10 Digital I/Os	93
10.10.1 Display of the Operational State.....	93
10.10.2 Power Supply	93
10.10.3 Digital Outputs.....	95
10.10.4 Digital Inputs.....	97

10.11 Profibus DP Interface	100
10.11.1 Profibus Termination	100
10.11.2 Shielding.....	100
10.11.3 Profibus Slave Address.....	100
10.11.4 Profibus Baud Rate	100
10.12 EtherCAT	101
10.13 Digital Sensor Interfaces	101
10.13.1 Termination Resistors	101
10.13.2 Wire Fault Monitoring	102
10.13.3 Connecting SSI Sensors	102
10.13.4 Connecting Incremental Sensors	105
10.14 E-Bus Interface	108
10.14.1 Configuration of the E-Bus Interface	108
10.15 CAN Bus Interfaces	109
10.15.1 CAN Bus Termination Resistor	110
10.15.2 Setting the CANopen Node-ID	110
10.15.3 Setting the CAN Bus Baud Rate	110
10.16 Serial Interfaces	111
10.17 Safety Functions	111
10.17.1 Watchdog	111
10.17.2 'Outputs Enabled' Output (LED «OutEN»)	111
10.17.3 Stopping the Application Program.....	112
10.18 Nameplate	113
11 Product Range	114
11.1 M3000® Starter Kits	114
11.2 M3000® Modules	115
11.2.1 Controller.....	115
11.2.2 Q-Modules.....	116
11.2.3 R-Modules (Remote Modules)	117
11.3 Power Supply for M3000® Modules	117
11.4 License Keys	118
11.5 Software	119
11.5.1 MACS (Moog Axis Control Software)	119
11.5.2 Software for R-Modules.....	119
11.6 Interface Cables	120
11.7 CAN Bus Accessories	120
11.8 Plug-In Terminal Strips	121
11.8.1 Number of Required Plug-In Terminal Strips	122
11.9 Training Programs	123
12 Appendix	124
12.1 Typographical Conventions	124
12.2 Abbreviations	125
12.3 Quoted Standards	127
12.3.1 CiA DS.....	127
12.3.2 DIN	127
12.3.3 DIN EN	127
12.3.4 IEC	128
12.3.5 ISO/DIS	128
12.3.6 TIA/EIA.....	129

13 Index	130
A...C	130
D...G	131
I...L	132
M...O	133
P...R	134
S...S	135
T...Z	136

List of Tables

Table 1: Dimensions of DIN Rail Modules	30
Table 2: Power Consumption	40
Table 3: Power Supply Conditions of the Module's Internal Electronics and the Sensors	41
Table 4: Connector Pin out.....	52
Table 5: Maximum Cable Lengths in Profibus Networks (Depending on the Transmission Rate)	53
Table 6: Maximum Permissible Stub Cable Length in Profibus Networks (Depending on the Transmission Rate)	53
Table 7: Suitable Cables for Profibus Interface Cables	53
Table 8: M3000® Modules with CAN Bus Interfaces	56
Table 9: Maximum Cable Lengths in CAN Bus Networks (Depending on the Transmission Rate).....	59
Table 10: Maximum Permissible Stub Cable Lengths in CAN Bus Networks	59
Table 11: Suitable Cables for CAN Bus Interface Cables	60
Table 12: Permissible Masters and Slaves in E-Bus Groups	61
Table 13: Update Rate of E-Bus Messages	62
Table 14: Update Order for Inputs and Outputs of QDIO and QAIO 16/4	63
Table 15: DIN Rail Modules with CAN and E-Bus Interfaces	64
Table 16: Terminal Assignment of MSC II's Connectors	78
Table 17: LEDs of the MSC II	81
Table 18: LEDs for Displaying Elementary Operational States and Errors after Switching on or Resetting the MSC II	83
Table 19: Behavior of the Run/Stop/Reset Switch	88
Table 20: U/I Working Ranges of MSC II control module's Digital Inputs (Current Consuming)	99
Table 21: Designations of Incremental Sensor Terminals (MSC II and Incremental Sensors from Various Manufacturers)	105
Table 22: Timing of incremental encoders	106
Table 23: Product Range – M3000® Starter Kits	114
Table 24: Product Range Motion Controller	115
Table 25: Product Range – Q-Modules	116
Table 26: Product Range – R-Modules (Remote Modules).....	117
Table 27: Product Range – Power Supply for M3000® Modules.....	117
Table 28: Product Range – License Keys	118
Table 29: Features Provided by the License Keys	118
Table 30: Product Range – Software – MACS	119
Table 31: Product Range – Software for R-Modules	119
Table 32: Product Range – Interface Cables	120
Table 33: Product Range – CAN Bus Accessories	120
Table 34: Product Range – Plug-In Terminal Strips	121
Table 35: Number of Plug-In Terminal Strips	122

Table 36: Product Range – Training Programs	123
Table 37: Abbreviations	125

List of Figures

Figure 1: MSC II Starter Kit.....	15
Figure 2: MSC I Control Module	16
Figure 3: MSC II Control Module	17
Figure 4: QDIO 16/16	18
Figure 5: QAIO 2/2.....	18
Figure 6: QAIO 16/4.....	18
Figure 7: QEBUS-CAN Extension Module.....	19
Figure 8: RDIO 16/16-0,5 Remote I/O Module	20
Figure 9: RDISP 22 Display and Operating Terminal	20
Figure 10: DialogController	21
Figure 11: MSD Motion Controller	22
Figure 12: MSD Servodrive	23
Figure 13: License Key	24
Figure 14: Front View of DIN Rail Modules	29
Figure 15: Side View of DIN Rail Modules.....	29
Figure 16: Dimensions of DIN Rail Modules.....	30
Figure 17: Arrangement of DIN Rail Modules on a Vertical Mounting Plate.....	31
Figure 18: Arrangement of DIN Rail Modules between Cable Conduits.....	32
Figure 19: Using a Shielding Bar when Connecting a Signal Cable to the MSC II.....	32
Figure 20: Unlocking a DIN Rail Module.....	33
Figure 21: Placing a DIN Rail Module onto a DIN Top-Hat Rail	34
Figure 22: Sliding a DIN Rail Module on a DIN Top-Hat Rail	34
Figure 23: DIN Rail Modules Joined Without Gaps on a DIN Top-Hat Rail.....	34
Figure 24: Fixing and Locking a DIN Rail Module	35
Figure 25: Unlocking a DIN Rail Module.....	36
Figure 26: Pulling apart DIN Rail Modules.....	36
Figure 27: Lifting off a DIN Rail Module from the DIN Top-Hat Rail	36
Figure 28: Grounding Concept	38
Figure 29: Correct Connection of DIN Rail Modules to Several Power Supplies	42
Figure 30: Correct Connection of DIN Rail Modules to a Single Power Supply	42
Figure 31: Correct Power Supply Connection of Sensors via a QDIO	44
Figure 32: Wrong Power Supply Connection of Sensors via a QDIO.....	45
Figure 33: Ethernet Network with exactly 2 Network Stations	47
Figure 34: Ethernet Network with more than 2 Network Stations	48
Figure 35: 100BaseT Cable with Crossed Twisted Pair Wires (Crossover Cable).....	48
Figure 36: 100BaseT Cable with Non-Crossed Twisted Pair Wires (Patch Cable)	48
Figure 37: EtherCAT Bus Topology.....	49

Figure 38: 100BaseT Cable with Non-Crossed Twisted Pair Wires (Patch Cable)	49
Figure 39: Linear Structure of the Profibus with Termination Resistors	51
Figure 40: 9 Pole D-sub Mating Connector with switchable termination according to IEC 61158/EN 50170.....	52
Figure 41: Profibus Interface - Connector with internal longitudinal inductivity according to IEC 61158/EN 50170.....	52
Figure 42: TIA/EIA 232 Null Modem Cable.....	54
Figure 43: TIA/EIA 232 Interface Cable with 1:1 Connection	54
Figure 44: Linear Structure of the CAN Bus	58
Figure 45: CAN Bus Interface Cable	59
Figure 46: E-Bus Group (MSC II as E-Bus Master).....	66
Figure 47: E-Bus Group (RDIO as E-Bus Master).....	66
Figure 48: LocalCAN Bus Group (MSC IIs as CAN Bus Network Stations)	67
Figure 49: WideCAN Bus Group (MSC IIs and R-Modules as CAN Bus Network Stations)	68
Figure 50: Repair Seal.....	70
Figure 51: Dimensions of the MSC II.....	74
Figure 52: Block Diagram of the MSC II	76
Figure 53: Front View of the MSC II	77
Figure 54: Front Panel of the MSC II	77
Figure 55: License Key of the MSC II control module with Attachment Screws	86
Figure 56: Timing diagram of the MSC II control module	91
Figure 57: Basic Wiring Diagram of a Digital Open Emitter/Collector Output of the MSC II.....	95
Figure 58: Basic Wiring Diagram of a Digital Input of the MSC II (Current Consuming).....	97
Figure 59: U/I Working Ranges of MSC II control module's Digital Inputs (Current Consuming).....	99
Figure 60: Profibus DP Interface of the MSC II	100
Figure 61: Connection Diagram of the MSC II in Master Mode	103
Figure 62: Connection Diagram of the MSC II in Slave Mode.....	104
Figure 63: Signals Between the MSC II and a 16 Bit SSI Sensor (Example).....	104
Figure 64: Connection Diagram of the MSC II with an Incremental Sensor	105
Figure 65: Timing requirements of incremental encoder signals	106
Figure 66: Timing of Standard Incremental Encoder	106
Figure 67: Timing of Pulse Train Incremental Encoder with positive logic	107
Figure 68: Timing of Pulse Train Incremental Encoder with negative logic.....	107
Figure 69: Timing of Frequency Modulation Incremental Encoder with positive logic.....	107
Figure 70: Timing of Frequency Modulation Incremental Encoder with negative logic.....	107
Figure 71: CAN Bus Interfaces of the MSC II.....	109
Figure 72: Position of the Nameplate on the MSC II	113

1 General Information

1.1 About this Manual

This manual is valid only for the M3000[®] automation system and M3000[®] modules. It contains most important instructions that must be observed in order to operate the M3000[®] automation system and M3000[®] modules in a safe manner.

Every person responsible for machinery planning, mounting, and operation must read, understand, and follow all points covered in this manual. This applies especially to the safety instructions. Following the safety instructions helps to avoid accidents, faults, and material damage!

The following items must be observed as fundamental elements of safety when using the M3000[®] automation system and M3000[®] modules:

- All safety instructions contained in this manual
- All safety instructions contained in the documentation of the M3000[®] modules
- All safety instructions contained in the product related hardware and software documentation required for the relevant application
- All relevant nationally and internationally applicable safety and accident prevention regulations and standards

1.1.1 Reservation of Changes and Validity

The information contained in this manual is valid at the time of this version's release. See footer for version number and release date of this manual. Moog reserves the right to make changes to this manual at any time without specified reasons.

1.1.2 Exclusion of Liability

This manual was prepared with great care and the contents reflect the authors' best knowledge. However, the possibility of error remains and improvements are possible.

Please feel free to submit any comments regarding errors or incomplete information to Moog.

Moog does not offer any guarantee that the contents conform to applicable legal regulations nor does Moog accept any liability for incorrect or incomplete information and the consequences thereof.

1.1.3 Completeness

This manual is complete only when used in conjunction with the product related hardware and software documentation required for the relevant application.

1.1.4 Place of Storage

This manual and all other associated documentation for hardware and software must always be kept in a location where they will be readily accessible and close to the M3000[®] automation system and M3000[®] modules or the equipment in which they are installed.

About this Manual

Using M3000[®] Safely (Prerequisites)

Reservation of Changes and Validity for this Manual

Exclusion of Liability for this Manual

Completeness of this Manual

Place of Storage for this Manual

1.2 Selection and Qualification of Personnel

Only qualified users may work with and on the M3000[®] automation system or M3000[®] modules.

Qualified users are properly trained experts with the required knowledge and experience. In particular, these experts must have the authorization to bring into operation, ground, and label devices, systems, and power circuits in accordance with safety engineering standards. Those people working on a project must be familiar with safety concepts common in automation.

Qualified Users

1.3 Proper Use

The M3000[®] modular automation system is suitable for control applications in the medium to high end performance ranges.

M3000[®] is designed for use within the overvoltage category defined by IEC 60364-4-44 for controlling machines and industrial processes in low voltage systems in which the rated supply voltage does not exceed 1,000 V alternating current (50/60 Hz) or 1,500 V direct current.

Qualified project planning and design, proper transportation, storage, installation, and use are required to ensure fault-free, reliable, and safe operation of M3000[®].

M3000[®] and M3000[®] modules must not be brought into operation until it has been ensured that the equipment in which they are installed complies with the current version of the EU machinery directive.

The M3000[®] automation system and M3000[®] modules may be used only under the conditions and situations specified in this manual and in the documentation of the M3000[®] modules.

Any other or more extensive use is not permissible.

The following are also required for proper use:

- Compliance with the requirements detailed in this manual
- Compliance with the requirements of individual M3000[®] module documentation
- Compliance with all of the product related hardware and software documentation required for the relevant application
- Compliance with the relevant nationally and internationally applicable regulations, standards, and directives, e.g., the regulations specified by a professional organization, such as TÜV or VDE

Proper Use

1.3.1 Safety Related Systems

WARNING



As with any electronic automation system, the failure of certain components when using M3000[®] or M3000[®] modules might lead to an uncontrolled and/or unpredictable operational condition. The user should take into consideration the system level effects of all types of failures and implement corresponding safety measures.

Safety Related Systems

Special measures are required to use control technology in safety related systems.

When planning to use control technology in a safety related system, the user should seek detailed advice in addition to any available standards or guidelines for safety installations.

1.4 Warranty and Liability

Moog's standard delivery and payment conditions apply. The owner/operator will have access to these by the time the contract is closed at the latest.

Warranty and liability claims for personal and material damage will be excluded when they are the result of the following, among others:

- Improper use of the M3000[®] automation system or M3000[®] modules
⇒ "1.3 Proper Use" on page 2
- Use of the M3000[®] automation system or M3000[®] modules in a technically imperfect condition
- Use of the M3000[®] automation system or M3000[®] modules by unqualified users
⇒ "1.2 Selection and Qualification of Personnel" on page 2
- Failure to comply with this manual, the documentation of the M3000[®] modules, or the product related hardware and software documentation required for the relevant application
- Failure to comply with the relevant nationally and internationally applicable regulations such as the regulations of a professional association, the TÜV, or the VDE
- Improper deployment of the M3000[®] automation system or M3000[®] modules, such as in a potentially explosive, excessively warm, or excessively cold environment
- Improper storage, transportation, mounting, removing, connection, bringing into operation, operation, cleaning, or maintenance of the M3000[®] automation system or M3000[®] modules
- Storage or transportation of M3000[®] modules or accessories outside of the original packaging
⇒ "9 Transportation and Storage" on page 71
- Unauthorized or improperly executed structural changes to the M3000[®] automation system or M3000[®] modules
- Unauthorized or improperly executed repairs on the M3000[®] automation system or M3000[®] modules
⇒ "8.2.2 Repair" on page 70
- Damage due to the intrusion of foreign objects or acts of God.

Exclusion of Warranty and Liability

1.5 Inspection of Delivery

After receiving the delivery, please check the original packaging and its contents for any damage.

If the packaging or contents exhibit any damage, do not bring the items into operation. In this case, immediately notify Moog or the responsible supplier. In addition, the packaging should be retained. The packaging might be needed to enforce damage compensation claims on the transport company.

After taking the delivery, please check whether all items listed on the delivery docket are present. If anything is missing, immediately notify Moog or the responsible supplier.

It is advisable to retain the original packaging for any future transport or storage needs.

Inspection of Delivery

Retain the Original Packaging

1.6 Environmental Protection

1.6.1 Emissions

M3000[®] modules do not have any harmful emissions when used properly.

**Environmental Protection:
Emissions**

1.6.2 Disposal

 The applicable disposal regulations must be observed when disposing of M3000[®] modules!

**Environmental Protection:
Disposal**

1.7 Standards

1.7.1 CE Labeling of M3000[®] Modules



All M3000[®] modules comply with the standards specified in their relevant declaration of conformity. CE labeling of the M3000[®] modules is based on proper installation of the automation system with proven electromagnetic compatibility (EMC).

**CE Labeling of M3000[®]
Modules**

1.7.2 IEC 61131-2

The M3000[®] automation system and M3000[®] modules comply with the requirements of IEC 61131-2.

**M3000[®] and M3000[®]
Modules Comply with
IEC 61131-2**

 Where technical requirements lead to deviations from the standard, these are specified in this manual or in the documentation of the relevant M3000[®] modules.

1.7.3 Electromagnetic Compatibility (EMC)

M3000[®] modules comply with the requirements and protection targets of the EU directive 89/336/EEC "Electromagnetic Compatibility" (EMC directive) and comply with the harmonized European standards (EN) that were published in the Official Journals of the European Union for programmable controllers.

**Electromagnetic
Compatibility (EMC)**

Especially important are the rules for proper EMC wiring in cabinets and buildings according to IEC 61131-4. Installation in metal, grounded cabinets is preferred.

M3000[®] modules are designed for use under normal operating conditions in industrial environments and comply with the following standards:

- DIN EN 61000-6-2
- DIN EN 61000-6-4

If suitable additional measures are taken, M3000[®] modules may also be employed in residential, commercial and light-industrial environments in compliance with the following standards:

- DIN EN 61000-6-1
- DIN EN 61000-6-3

Suitable additional measures:

⇒ ["4.2 Use in Special Environments" on page 28](#)

If the system does not comply with the requirements of DIN EN 61000-6-1 and DIN EN 61000-6-3, despite the additional measures, M3000[®] modules must not be used in residential, commercial and light-industrial environments.

EMC conformity may be presumed only under the following conditions:

- Sufficient shielding
- Mounting of the DIN rail module onto a DIN top-hat rail that is attached to an electrically conductive, grounded mounting plate
⇒ [figure 17 on page 31](#)

MSC II and extension modules must be powered from a power supply with SELV (Safety Extra-Low Voltage) according to DIN EN 60950-1. Therefore the EU low voltage directive is not relevant for the M3000[®] automation system because the specified voltage levels lie below the limits.

1.8 Trademarks

Moog and Moog Authentic Repair are registered trademarks of Moog Inc. and its subsidiaries.

M3000[®] is a trademark of Moog GmbH that is registered in the EU.

-  All product and company names mentioned in this manual might be protected trademarks or brands of the relevant manufacturer. The absence of the symbols [®] or [™] does not indicate that the name is free from trademark protection.

1.9 Software Copyrights

The software that is installed on M3000[®] products at the time of delivery is the property of the manufacturer. At the time of delivery, every piece of installed software is covered by copyright protection. It may be reproduced only with the approval of the manufacturer or in accordance with the license agreements.

Trademarks

Software Copyrights

2 Safety Instructions

This chapter summarizes the most important safety instructions. When handling the M3000[®] automation system or M3000[®] modules the safety instructions in the other chapters of this manual must be followed as well as the safety instructions in the product related hardware and software documentation required for the specific application.

Following the safety instructions helps to avoid accidents, faults, and material damage!

2.1 Typographical Conventions

The following symbols and styles are used for identifying the different types of safety instructions:

**Safety Instructions:
Typographical
Conventions**

DANGER



Identifies safety instructions that are intended to warn of an immediate and impending danger to life and limb or major property damage.

Failure to observe these safety instructions will lead inevitably to death, serious personal injury (disablement) or major property damage!

WARNING



Identifies safety instructions that are intended to warn of potential danger to life and limb or the potential for major property damage.

Failure to observe these safety instructions might lead to death, serious personal injury (disablement) or major property damage!

CAUTION



Identifies safety instructions that are intended to warn of slight personal injury or minor property damage.

Failure to observe these safety instructions might lead to slight personal injury or minor property damage.

Additional typographical conventions:

⇒ ["12.1 Typographical Conventions" on page 124](#)

2.2 Safety Instructions

2.2.1 Safety Related Systems

WARNING



As with any electronic automation system, the failure of certain components when using M3000[®] or M3000[®] modules might lead to an uncontrolled and/or unpredictable operational condition. The user should take into consideration the system level effects of all types of failures and implement corresponding safety measures.

**Safety Instructions: Safety
Related Systems**

More on this subject: ⇒ ["1.3.1 Safety Related Systems" on page 2](#)

2.2.2 Environmental Conditions

WARNING

Maintain under all circumstances the required environmental conditions specified for the M3000[®] automation system or M3000[®] modules.

This ensures fault-free, reliable, and safe operation.

**Safety Instructions:
Environmental Conditions**

WARNING

The PC on which tools such as MACS development environment are installed must be suitable for the environmental conditions in which it will operate.

This ensures fault-free, reliable, and safe operation.

WARNING

It is not permissible to operate the M3000[®] automation system or M3000[®] modules in a potentially explosive environment.

WARNING

The M3000[®] automation system and M3000[®] modules must not come into direct contact with liquids, except where explicitly specified. **Danger of short-circuit!**

If they do come into direct contact with a liquid, immediately disconnect the power supply! Before bringing the system back into operation, it is essential that all affected components are completely dry and have been inspected by a suitably qualified technician.

More on this subject:

⇒ ["4 Environmental Conditions" on page 27](#)

⇒ ["10.2.2 Environmental Conditions" on page 74](#)

2.2.3 ESD

WARNING

Protect the M3000[®] automation system, M3000[®] modules, and the license key from electrostatic discharges!

Electrostatic discharges might damage the device's internal components or delete the device's internal memory.

Safety Instructions: ESD

2.2.4 Project Planning and Installation

WARNING

The vent holes of M3000[®] modules facilitate convection cooling and must never be covered! Covered vent holes might result in overheating and fire.

**Safety Instructions:
Project Planning and
Installation**

WARNING

No work of any kind, such as mounting, removing, wiring, or repairs to the M3000[®] automation system or M3000[®] modules may be performed while the automation system or the modules are in operation!

There is a danger of:

- Uncontrolled movements
- Permanent damage
- Malfunctions

Before performing any work on the M3000[®] automation system or M3000[®] modules, it is essential that the system is stopped and the power supply is disconnected.

Therefore, all power supplies must be switched off, including those from attached peripherals such as externally supplied transmitters, programming devices, etc.!

WARNING

M3000[®] modules must be protected from overvoltages and/or reverse energization from the sensor to the module!

There is a danger of:

- Permanent damage by overheating or fire
- Malfunctions

M3000[®] modules must have the correct voltage, polarity, and terminal assignments.

WARNING

The internal electronics of M3000[®] modules and attached sensors must be supplied with power from a permanently connected (unswitched) power supply that cannot be individually switched off, without switching off the module's power supply.

If a switched power supply is used, such as when there are intermediate switching devices (emergency stops, manual operators, etc.), the following problems might arise, depending on the state of the power supply for the internal electronics of the module and sensors (⇒ [table 3 on page 41](#)):

- Reverse energization from sensor to module
- Invalid sensor data

WARNING

Sensors that are connected to digital inputs of M3000® modules with several I/O groups, such as MSC I, QDIO, or RDIO, must under all conditions be supplied from the same power supply as the corresponding I/O group to which the sensor is connected!

Otherwise, if the power supply for the internal electronics of the module is switched off, there might be reverse energization from the sensor to the module.

There is a danger of:

- Uncontrolled movements
- Fault or failure of a manual control
- Permanent damage to the module
- Malfunctions

Digital I/Os of MSC II and MSD Motion Controller are protected against reverse energization.

More on these subjects:

⇒ "5 Mechanical Installation" on page 29 or

⇒ "6 Project Planning and Installation" on page 37

2.2.5 Shutdown and Service

WARNING

To avoid damage to M3000® modules or accessories, cleaning, maintenance, and repair tasks may be performed only by Moog or Moog's authorized service agents.

Warranty and liability claims for personal and material damage are excluded when, among other reasons, they are due to unauthorized repairs or other unauthorized interventions.

⇒ "1.4 Warranty and Liability" on page 3

**Safety Instructions:
Shutdown and Service**

WARNING

No work of any kind, such as mounting, removing, wiring, or repairs to the M3000® automation system or M3000® modules may be performed while the automation system or the modules are in operation!

There is a danger of:

- Uncontrolled movements
- Permanent damage
- Malfunctions

Before performing any work on the M3000® automation system or M3000® modules, it is essential that the system is stopped and the power supply is disconnected.

Therefore, all power supplies must be switched off, including those from attached peripherals such as externally supplied transmitters, programming devices, etc.!

WARNING

The M3000[®] automation system and M3000[®] modules must not come into direct contact with liquids, except where explicitly specified. Danger of short-circuit!

If they do come into direct contact with a liquid, immediately disconnect the power supply! Before bringing the system back into operation, it is essential that all affected components are completely dry and have been inspected by a suitably qualified technician.

WARNING

If an M3000[®] module is to be taken out of operation, the entire system must always be shut down and disconnected from all power supplies.

Therefore, all power supplies must be switched off, including those from attached peripherals such as externally supplied transmitters, programming devices, etc.! The M3000[®] module must be protected against unintentional restarting!

If the M3000[®] module is connected to other devices and/or facilities, always consider the full consequences and take appropriate precautions before switching off the module.

More on these subjects:

⇒ ["8 Shutdown and Service" on page 69](#)

2.2.6 Transportation and Storage

WARNING

Maintain, under all circumstances, the required environmental conditions specified for transportation and storage of the M3000[®] automation system or M3000[®] modules.

⇒ ["9.1 Environmental Conditions" on page 71](#)

This ensures fault-free, reliable, and safe operation.

**Safety Instructions:
Transportation
and Storage**

More on this subject: ⇒ ["9 Transportation and Storage" on page 71](#)

2.2.7 Communication Between MSC II and MACS

WARNING



The MSC II control module's operational state can be altered with the MACS development environment when the MSC II control module is connected online with MACS.

This can be done by means of the following actions, for example:

- Stopping or resetting the program
- Setting breakpoints
- Activating the single step mode
- Downloading application programs
- Writing or forcing values

Therefore, the operator must always consider the effects and take appropriate precautions before altering the operational state of the MSC II control module with MACS.

More on this subject:

⇒ ["10.5 Programming and Configuration"](#) on page 84

Safety Instructions:
Communication Between
MSC II and MACS

2.2.8 License Key of the MSC II

WARNING



The license key of the MSC II control module must be protected from electrostatic discharges!

Electrical discharges might damage the license key or delete the contents of the license key's memory.

WARNING



The license key may be inserted or removed only when the MSC II control module is powered down!

Attempting to insert or remove the license key during operation might damage the license key or the MSC II control module permanently.

WARNING



The license key must always remain inserted while the MSC II control module is in operation. Otherwise, the MSC II control module will not work.

If the license key is removed during operation, the application program will stop after a few minutes. If the MSC II control module is connected online to the MACS development environment, a corresponding error message will appear in MACS.

In addition, the digital output 'Outputs Enabled' will be switched to the 0 state, thereby disabling all of the MSC II control module's digital outputs and terminating fieldbus communication and E-bus communication.

⇒ ["10.17.2 'Outputs Enabled' Output \(LED «OutEN»\)"](#) on page 111

After switching off the MSC II control module and inserting the license key, the MSC II control module can be brought back into operation.

More on this subject: ⇒ ["10.6 License Key"](#) on page 85

Safety Instructions:
License Key of the
MSC II

2.2.9 Run/Stop/Reset

WARNING

If the most recent status in the online mode (MACS logged in) was 'Run' before the MSC II control module was switched off or reset, the boot project will always be started after the MSC II control module is switched back on or reset.

This will occur regardless of which application program was previously running.

In other words, the application program that will be started automatically after the MSC II control module is switched on or reset might be different from the application program that was executing immediately prior.

Safety Instructions:
Run/Stop/Reset

More on this subject: ⇒ ["10.7 Run/Stop/Reset Switch" on page 88](#)

2.2.10 Switching Back on or Resetting the MSC II

WARNING

If the most recent status in the online mode (MACS logged in) was 'Run' before the MSC II control module was switched off or reset, the boot project will always be started after the MSC II control module is switched back on or reset.

This will occur regardless of which application program was previously running.

In other words, the application program that will be started automatically after the MSC II control module is switched on or reset might be different from the application program that was executing immediately prior.

Safety Instructions:
Switching Back on or
Resetting the MSC II

More on this subject:

⇒ ["10.8.1 Behavior at Switching on and Switching off" on page 89](#)

2.2.11 'Outputs Enabled' Output of the MSC II

WARNING

If there is a defect in an output stage, the 'Outputs Enabled' signal will not necessarily shut down all of the outputs securely.

Safety Instructions:
'Outputs Enabled' Output
of the MSC II

More on this subject:

⇒ ["10.17.2 'Outputs Enabled' Output \(LED «OutEN»\)" on page 111](#)

3 Short M3000® System Overview

The M3000® automation system comprises the following hardware and software components:

**Short M3000®
System Overview**

- **MSC II starter kit**
Complete package including everything needed to get started with MSC II
⇒ "3.2 MSC II Starter Kit" on page 15
- **M3000® modules**
 - **MSC I (Moog Servo Controller)**
Control module for DIN top-hat rail mounting
⇒ "3.3.1 MSC I" on page 16
 - **MSC II (Moog Servo Controller)**
Control module for DIN top-hat rail mounting
⇒ "3.3.2 MSC II" on page 17
 - **QDIO 16/16**
Digital I/O extension module for local extension of the inputs and outputs of MSC I or MSC II (connection over E-bus)
⇒ "3.3.3.1 QDIO and QAIO" on page 18
 - **QAIO 2/2**
Analog I/O extension module for local extension of the inputs and outputs of MSC I or MSC II (connection over E-bus)
⇒ "3.3.3.1 QDIO and QAIO" on page 18
 - **QAIO 16/4**
Analog I/O extension module for local extension of the inputs and outputs of MSC I or MSC II (connection over E-bus)
⇒ "3.3.3.1 QDIO and QAIO" on page 18
 - **QEBUS-CAN**
CAN extension module for MSC II which can be used to make available the LocalCAN bus of an E-bus group for external CAN bus network stations (over a D-sub front panel connector)
⇒ "3.3.3.2 QEBUS-CAN" on page 19
 - **RDIO**
Remote module with digital I/Os and CANopen interface (connection over CAN bus)
⇒ "3.3.4.1 RDIO" on page 20
 - **RDISP**
Display and operating terminal with TIA/EIA 232 and CANopen interface (connection over CAN bus)
⇒ "3.3.4.2 RDISP" on page 20
 - **DialogController**
Displays with TFT technology and touch screen. Programmable with MACS development environment. Data exchange via Ethernet with MSC II or MSD Motion Controller.
⇒ "3.3.4.3 DialogController" on page 21
 - **MSD Motion Controller**
Motion control module for MSD Servodrives
⇒ "3.3.5 MSD Motion Controller" on page 22
 - **MSD Servodrive**
Modular Multi-Axis Programmable Motion Control Servodrive
⇒ "3.3.6 MSD Servodrive" on page 23
- **License keys**
Hardware keys necessary for the operation of the MSC I, MSC II and MSD Motion Controller.
⇒ "3.4 License Key" on page 24

- **MACS (Moog Axis Control Software)**
Development environment according to IEC 61131 for solving complex control tasks
⇒ ["3.5 Application Programs" on page 25](#)
- **MACS HMI (Moog Axis Control Software Human Machine Interface)**
Visualization package which can be run without MACS
⇒ ["3.6.1 MACS HMI Visualization Package" on page 26](#)

i The M3000® modules mentioned here represent only a part of Moog's current product range. In addition to other M3000® modules, Moog's product range includes a large variety of accessories.
⇒ ["11 Product Range" on page 114](#)

3.1 M3000® System Architecture

The M3000® automation system has the hardware and software structure necessary for modular and flexible automation solutions with distributed intelligence.

The MSC II control module can use an Ethernet connection (LAN, company network, peer-to-peer connection) to communicate with another controller, development environment, or visualization package.

- ⇒ ["7.1 Ethernet" on page 47](#)
- ⇒ ["10.5.1 Communication Between MSC II and MACS" on page 84](#)
- ⇒ ["10.5.1.1 Ethernet Communication Interface" on page 84](#)

To create real time capable applications, even in distributed systems and to give the application a better structure, M3000® can also be divided hierarchically.

- ⇒ ["7.5 CAN Bus and CANopen" on page 55](#)

WideCAN and LocalCAN are two equal, mutually independent CAN bus interfaces. In a typical application they are used as follows:

- **WideCAN** can be used for networking of individual control groups or remote modules. Usually, WideCAN is used for synchronization and data exchange between the control groups and operating stations of a machine or system.
⇒ ["3.3.4 R-Modules \(Remote Modules\)" on page 19](#)
⇒ ["7.7.4 WideCAN Bus Groups" on page 67](#)
In addition, the WideCAN network can integrate other components with a CAN bus or CANopen interface, such as motor controllers, hydraulic valves, and radial piston pumps.
- **LocalCAN** connects the DIN rail modules within a LocalCAN bus group and, if applicable, the QEBUS-CAN to the connected LocalCAN bus groups or CAN sensors/actuators.
⇒ ["3.3.3.2 QEBUS-CAN" on page 19](#)
⇒ ["7.7.3 LocalCAN Bus Groups" on page 66](#)

M3000® System Architecture

Ethernet

CAN Bus

WideCAN

LocalCAN

3.2 MSC II Starter Kit

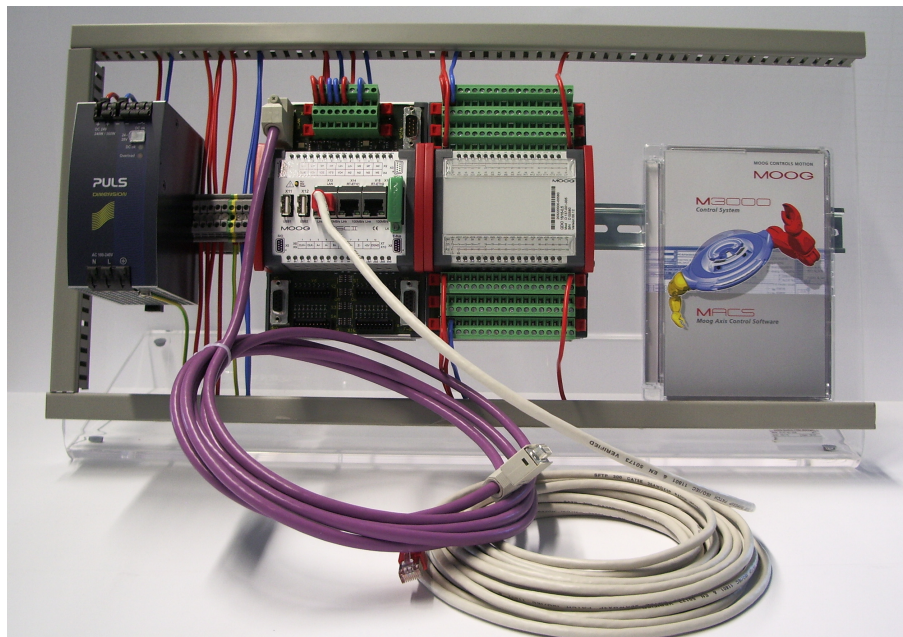

MSC II Starter Kit

Figure 1: MSC II Starter Kit

The MSC II starter kit is available in two versions:

- MSC II with Profibus-DP slave
- MSC II with dual EtherCAT master

It includes everything needed to get started:

- MSC II
- Power supply 24 V 10 A
- License key, green
- QDIO 16/16-0,5
- MACS development environment
- Software maintenance contract
- Crossed Ethernet interface cable, 10 m (10.94 yd)
- CAN bus interface cable, 3 m (3.28 yd)
- 6 Plug-in terminal strips with screw terminals, 18 pole
- 2 Plug-in terminal strip with screw terminals, 9 pole
- 4 Plug-in terminal strips with spring power clamp, 10 pole

The included DIN rail modules MSC II and QDIO are mounted (together with the power supply) on a single mounting plate.

A suitable power cord is the only additional item required to facilitate connection to the power source.

3.3 M3000® Modules

- i** The M3000® modules mentioned here represent only a part of Moog's current product range. In addition to other M3000® modules, Moog's product range includes a large variety of accessories.
 ⇒ "11 Product Range" on page 114

3.3.1 MSC I

MSC I

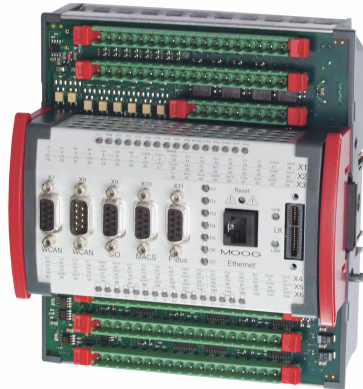

Figure 2: MSC I Control Module

The MSC I digital control module is a fully programmable multi-axis controller. The inputs and outputs of the MSC I can be extended locally by attaching Q-modules. The MSC I and the attached modules then form an E-bus group. MSC I and Q-modules within E-bus groups communicate over the internal E-bus.

The MSC I is programmed and configured with the MACS development environment (complies with IEC 61131).

⇒ "3.5 Application Programs" on page 25

3.3.2 MSC II

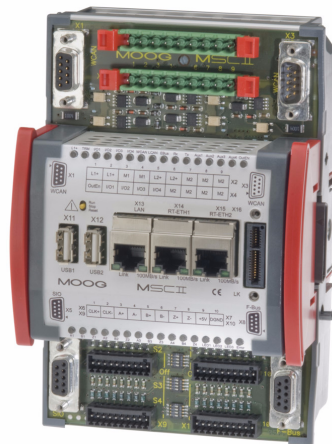

MSC II

Figure 3: MSC II Control Module

The MSC II digital control module is a fully programmable multi-axis controller.

The inputs and outputs of the MSC II can be extended locally by attaching Q-modules. The MSC II and the attached modules then form an E-bus group. MSC IIs and Q-modules within E-bus groups communicate over the internal E-bus.

⇒ ["7.7.2 E-Bus Groups" on page 65](#)

The MSC II is programmed and configured with the MACS development environment (complies with IEC 61131).

⇒ ["3.5 Application Programs" on page 25](#)

i Detailed information about the MSC II:
 ⇒ ["10 MSC II \(Moog Servo Controller\)" on page 72](#)

3.3.3 Q-Modules

Q-Modules are I/O extension modules for MSC I and MSC II.

Q-Modules

The following Q-modules are available from Moog:

- QDIO 16/16 (digital I/O extension module)
 ⇒ ["3.3.3.1 QDIO and QAIO" on page 18](#)
- QAIO 2/2 (analog I/O extension module)
 ⇒ ["3.3.3.1 QDIO and QAIO" on page 18](#)
- QAIO 16/4 (analog I/O extension module)
 ⇒ ["3.3.3.1 QDIO and QAIO" on page 18](#)
- QEBUS-CAN (CAN extension module)
 ⇒ ["3.3.3.2 QEBUS-CAN" on page 19](#)

Q-modules can be used only as E-bus slaves within E-bus groups.

⇒ ["7.7.2 E-Bus Groups" on page 65](#)

When using an RDIO as E-bus master, only QDIOs can be used as E-bus slaves.

⇒ ["7.6.2.1 E-Bus Master and E-Bus Slaves" on page 61](#)

i Refer to the Q-modules' documentation for more detailed information.

3.3.3.1 QDIO and QAIO

QDIO and QAIO

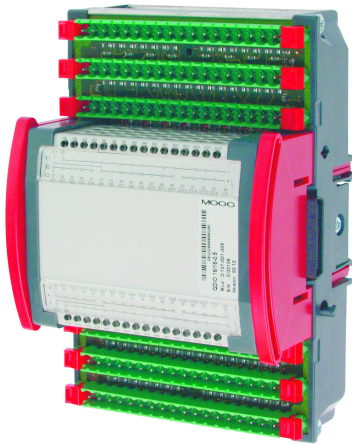

Figure 4: QDIO 16/16

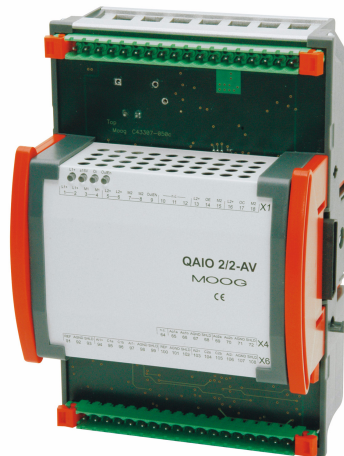

Figure 5: QAIO 2/2

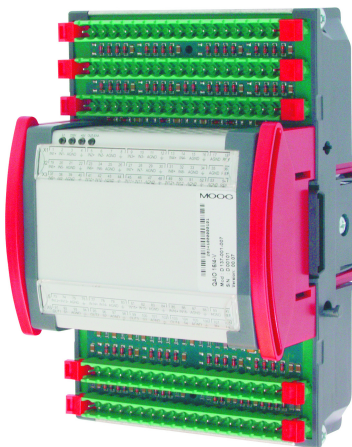

Figure 6: QAIO 16/4

QDIO and QAIO I/O extension modules can be used to locally extend the inputs and outputs of an MSC I or MSC II. They have no internal intelligence. Instead, the MSC I or MSC II actuates them via I/O operation directly over the internal E-bus.

QDIO 16/16-0,5 is a digital I/O extension module with 16 digital inputs and 16 individually configurable digital I/Os.

QDIO 16/16-0,5 provides positive switching inputs and I/Os.

QDIO 16/16-0,5N provides zero switching inputs and I/Os.

QAIO 2/2 is an analog I/O extension module with 2 analog inputs (each configurable as ± 10 V, ± 10 mA, 4-20 mA) and 2 analog voltage outputs (± 10 V additionally each configurable as ± 10 mA, 4-20 mA, ± 50 mA).

QAIO 16/4 is an analog I/O extension module with 16 analog inputs and 4 analog voltage outputs (± 10 V).

QAIO 16/4-V provides 16 voltage inputs (± 10 V).

QAIO 16/4-A provides 16 current inputs (0–20 mA).

QDIO 16/16-0,5

QAIO 2/2

QAIO 16/4

3.3.3.2 QEBUS-CAN



Figure 7: QEBUS-CAN Extension Module

QEBUS-CAN

QEBUS-CAN is a CAN extension module which can be used to make the LocalCAN bus of an E-bus group available for external CAN bus network stations (over a D-sub front panel connector).

3.3.4 R-Modules (Remote Modules)

R-Modules are extension modules with CANopen interface.

The following R-modules are available from Moog:

- RDIO (remote module with digital I/Os and CANopen interface)
⇒ "3.3.4.1 RDIO" on page 20
- RDISP (display and operating terminal)
⇒ "3.3.4.2 RDISP" on page 20

IEC 61131 application programs cannot run on R-modules.

R-modules connect to other network stations over the CAN bus.

⇒ "7.4.1 TIA/EIA 232 Interface Cables" on page 54

i Refer to the R-modules' documentation for more detailed information.

R-Modules (Remote Modules)

3.3.4.1 RDIO

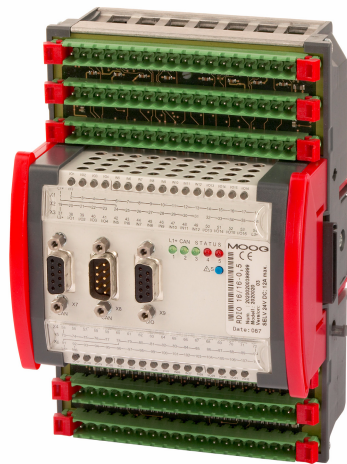

Figure 8: RDIO 16/16-0,5 Remote I/O Module

RDIO

RDIO is a remote module with digital I/Os and CANopen interface. RDIOs can be parameterized as a CANopen slave according to CiA DS 401.

RDIO 16/16-0,5 provides 16 positive switching digital inputs and 16 positive switching digital I/Os.

RDIO 16/16-0,5

3.3.4.2 RDISP



Figure 9: RDISP 22 Display and Operating Terminal

RDISP

RDISP is a versatile display and operating terminal with TIA/EIA 232 and CANopen interface as well as a graphical LCD display and function keys which can be labelled. A slip of paper can be inserted below the keys for labelling purposes.

RDISP 22 provides 22 function keys and a display with max. 8 lines of 40 characters each or random graphics.

RDISP 22

Dimensions of RDISP 22:

187 mm × 120 mm × 56 mm (7.36 in × 4.72 in × 2.2 in)

i The CPRDISP software (needed to program and configure the RDISP) is not included with RDISP. CPRDISP is available from Moog as an accessory.

CPRDISP

⇒ ["11.5.2 Software for R-Modules" on page 119](#)

3.3.4.3 DialogController



DialogController

Figure 10: DialogController

The DialogController is freely programmable with the Moog Axis Control Software (MACS) development environment. The predefined visualization elements such as buttons, bar graphs, meters, tables and histograms makes it easy to create visualization screens.

In addition it offers TFT technology for brilliant colors, fanless operation, Ethernet communication for programming and operation.

It is available in three sizes:

- DialogController 5.7 "
Color TFT, ¼ VGA resolution, 320 x 240 pixels with touch screen
Dimensions: W x D x H: 194 x 172 x 52 mm / 7.6 x 6.8 x 2.0 inch
- DialogController 10.4 "
Color TFT, VGA resolution, 640 x 480 pixels with touch screen
Dimensions: W x D x H: 360 x 260 x 77 mm / 14.2 x 10.2 x 3.0 inch
- Display 12.1 "
Color TFT, SVGA resolution, 800 x 600 pixels with touch screen
Dimensions: W x D x H: 440 x 300 x 77 mm / 17.3 x 11.8 x 3.0 inch

3.3.5 MSD Motion Controller

MSD Motion Controller



Figure 11: MSD Motion Controller

Motion control module for MSD Servodrives.

The MSD Motion Controller digital control module is a fully programmable multi-axis controller.

It can coordinate and synchronize multiple axis e.g. of MSD Servodrives and handle the communication to host computers and other PLC's.

The MSD Motion Controller is programmed and configured with the MACS development environment (complies with IEC 61131).

3.3.6 MSD Servodrive



MSD Servodrive

Figure 12: MSD Servodrive

Modular Multi-Axis Programmable Motion Control Servodrive.

A family of electrical servo drives, available in 6 sizes for currents from 4 to 170 A.

Main features are:

- Controls synchronous motors, asynchronous motors and linear motors.
- Controls current loops (PWM frequencies: 4, 8, 12 and 16 kHz).
- Can close velocity and position control loops.
- Communicates with the MSD Motion Controller via EtherCAT.
- Supports different sensor interfaces.
- Digital I/O's.

3.3.7 Identification

M3000® modules can be identified by their nameplate.

Nameplate of the MSC II: ⇒ ["10.18 Nameplate" on page 113](#)

The module's I/O designations are located on the front panel.

Terminal assignment of the MSC II:

⇒ ["10.4 View of the Module and Terminal Assignment" on page 77](#)

- ❗ Refer to the relevant documentation for detailed information about the nameplate and terminal assignment of the other M3000® modules.

Identification of
M3000® Modules

3.4 License Key

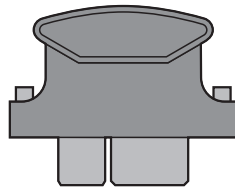

Figure 13: License Key

License Key

The license key has to be inserted into the license key slot «LK» of the MSC II.

The MSC II control module does not work without license key.

⇒ ["10.6 License Key" on page 85](#)

The following information is saved in the license key:

- Run-time license of the MSC II and list of accessible MACS libraries
⇒ ["10.6.1 Run-Time License and Accessible Libraries" on page 85](#)
- CANopen node-ID of the MSC II's CAN bus interfaces
⇒ ["10.6.2 CANopen Node-ID and IP Address" on page 86](#)
- IP address, subnet mask and gateway address of the MSC II's Ethernet interface
⇒ ["10.6.2 CANopen Node-ID and IP Address" on page 86](#)

If the MSC II is replaced, this information will remain saved in the license key.

If the license key is inserted into a different MSC II, the run-time license, CANopen node-ID and IP address can be used from that MSC II.

 The extent of the MSC II's features depends on the license key used.
⇒ ["11.4 License Keys" on page 118](#)

3.5 Application Programs

Application programs have to be downloaded onto the MSC II and started to be executed by the MSC II.

The MACS development environment is needed to create executable IEC 61131 application programs for the MSC II. With MACS, the application program can be programmed, compiled, downloaded and started.

⇒ "3.6 MACS Development Environment" on page 25

⇒ "10.5.1 Communication Between MSC II and MACS" on page 84

Application programs can be saved and executed in the MSC II in the following manner:

- As a boot project in the flash EEPROM
- In RAM

An application program saved as a boot project will be loaded into RAM whenever the MSC II's power supply is switched on or when the MSC II is reset.

i An application program that is only executed in RAM without being saved as a boot project will **not** be saved in the MSC II when it is switched off or when the power supply fails or the Run/Stop/Reset switch is moved to the Reset position.

After the power supply is switched back on or the Run/Stop/Reset switch is released from the Reset position, the application program must be downloaded again from the MACS development environment!

Behavior of the MSC II at switching on and switching off the power supply:

⇒ "10.8.1 Behavior at Switching on and Switching off" on page 89

3.6 MACS Development Environment

WARNING



The PC on which tools such as MACS development environment are installed must be suitable for the environmental conditions in which it will operate.

This ensures fault-free, reliable, and safe operation.

MACS must be installed on a personal computer (PC). This PC then represents the PADT (programming and diagnostic tool) specified in IEC 61131.

Scope of functionality of MACS

- Programming, testing, and optimization of IEC 61131 application programs
- Documentation of IEC 61131 application programs
- Visualization of IEC 61131 application programs
- Hardware configuration of M3000® modules

MACS supports the following programming languages:

- Instruction List (IL)
- Structured Text (ST)
- Ladder Diagram (LD)
- Function Block Diagram (FBD)
- Sequential Function Chart (SFC)
- Continuous Function Chart (CFC)

Application Programs

Scope of Functionality of MACS

Programming Languages of MACS

- ① Refer to the documentation for the MACS development environment for more detailed information.
- ① The MACS development environment is available from Moog as an accessory.
⇒ "11.5 Software" on page 119

3.6.1 MACS HMI Visualization Package

MACS is also available from Moog as a MACS HMI visualization package.
⇒ "11.5 Software" on page 119

**MACS HMI
Visualization Package**

MACS HMI can be used only for the visualization of an application program. It does not include any functionality for creating or editing application programs.

4 Environmental Conditions

WARNING



Maintain under all circumstances the required environmental conditions specified for the M3000[®] automation system or M3000[®] modules.

This ensures fault-free, reliable, and safe operation.

**Environmental
Conditions:
Safety Instructions**

WARNING



The PC on which tools such as MACS development environment are installed must be suitable for the environmental conditions in which it will operate.

This ensures fault-free, reliable, and safe operation.

WARNING



It is not permissible to operate the M3000[®] automation system or M3000[®] modules in a potentially explosive environment.

WARNING



The M3000[®] automation system and M3000[®] modules must not come into direct contact with liquids, except where explicitly specified. Danger of short-circuit!

If they do come into direct contact with a liquid, immediately disconnect the power supply! Before bringing the system back into operation, it is essential that all affected components are completely dry and have been inspected by a suitably qualified technician.

4.1 Requirements of IEC 61131-2

The M3000[®] automation system and M3000[®] modules comply with the requirements of IEC 61131-2.

- ① Where technical requirements lead to deviations from the standard, these are specified in this manual or in the documentation of the relevant M3000[®] modules.

Environmental conditions for the MSC II:

⇒ "[10.2.2 Environmental Conditions](#)" on page 74

- ① Refer to the relevant documentation for the specified environmental conditions for the other M3000[®] modules.

**Environmental
Conditions: Requirements
of IEC 61131-2**

4.2 Use in Special Environments

In the following cases, M3000® modules must **not** be used without taking additional measures:

- At sites with difficult operating conditions, like those caused by
 - Large amounts of dust
 - Elevated air humidity
 - Aggressive vapors or gases
 - Corrosive atmospheres
 - Potentially explosive environments

In these cases, the suitable additional measures to be taken may include, for example, installation in specially designed cabinets.

- In systems that require special monitoring, such as:
 - Elevators
 - Electrical systems located in particularly (potentially) hazardous environments
 - In residential, commercial, and light-industrial environments
 - In medical environments

Examples of suitable additional measures in these cases may include:

- Installation in grounded, shielded metal cabinets
- Installation of filters in the power supply cables
- Use of shielded cables outside of cabinets

Limitations of Using M3000® Modules

5 Mechanical Installation

M3000® modules are divided according to their mechanical construction into the following categories:

- DIN rail modules (such as MSC I, MSC II, QAIO, or QDIO)
- Other M3000® modules (such as RDISP)

Information about the DIN rail modules:

⇒ ["5.1 DIN Rail Modules" on page 29](#)

i Refer to the relevant documentation for the dimensions of the other M3000® modules and information about their mounting/removing.

Categories of M3000® Modules

5.1 DIN Rail Modules

5.1.1 Views of the Module

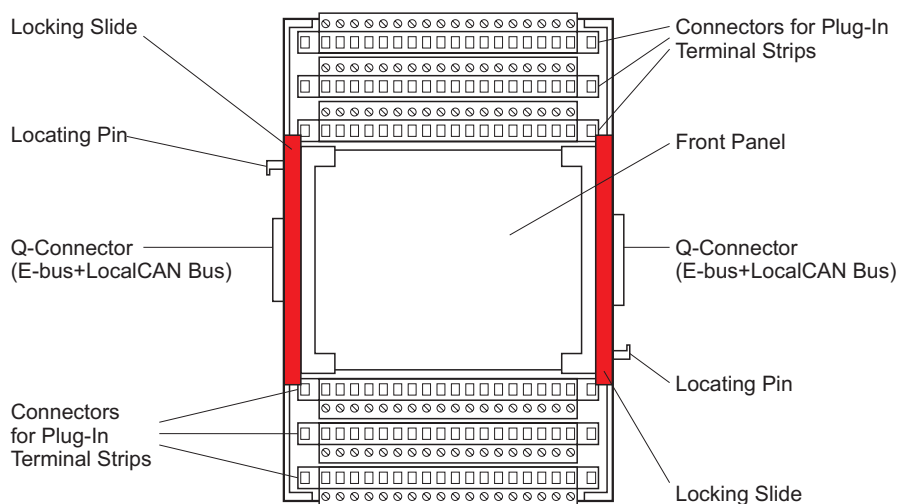

Figure 14: Front View of DIN Rail Modules

Front View of DIN Rail Modules

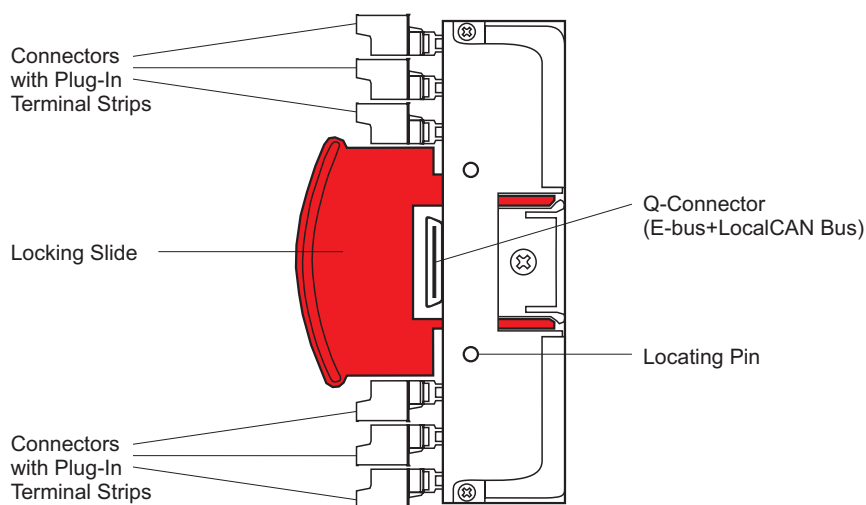

Figure 15: Side View of DIN Rail Modules

Side View of DIN Rail Modules

5.1.2 Dimensions

Due to the lateral locating pins, the DIN rail module's installation width will depend on whether it will be installed as a single module, row module, or end module.

Dimensions of DIN Rail Modules

	Installed As		
	Individual Module	Row Module	End Module
Installation Width	Module width + 11 mm (0.43 in) (locating pins protrude at the left and right)	Module width (locating pins disappear into the adjacent modules)	Module width + 5.5 mm (0.22 in) (locating pins protrude on only one side)
Height	170 mm (6.69 in)		
Depth	85.5 mm (3.37 in) (without accessories like mating connectors or plug-in terminal strips) When accessories like mating connectors or plug-in terminal strips are used, an installation depth of 50 mm (2 in) is usually required.		

Table 1: Dimensions of DIN Rail Modules

i Refer to the relevant documentation for the overall widths of the various DIN rail modules.

Dimensions of the MSC II:

⇒ "10.2 General Specifications" on page 73

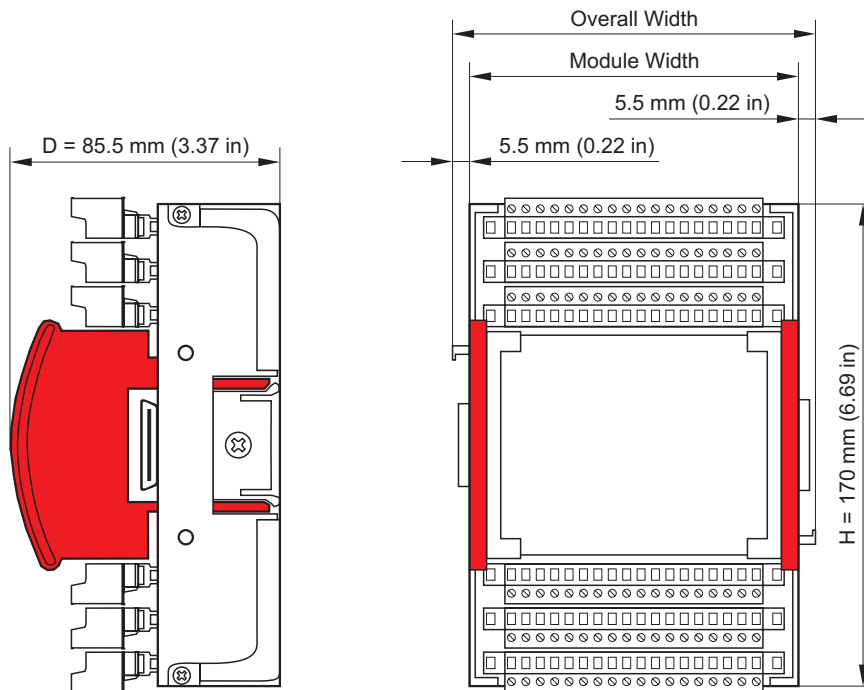

Figure 16: Dimensions of DIN Rail Modules

5.1.3 Arrangement on DIN Top-Hat Rails

WARNING



The vent holes of DIN rail modules facilitate convection cooling and must never be covered! Covered vent holes might result in overheating and fire.

DIN rail modules must be arranged next to each other on a DIN top-hat rail TH 35-7.5 in accordance with DIN EN 60715.

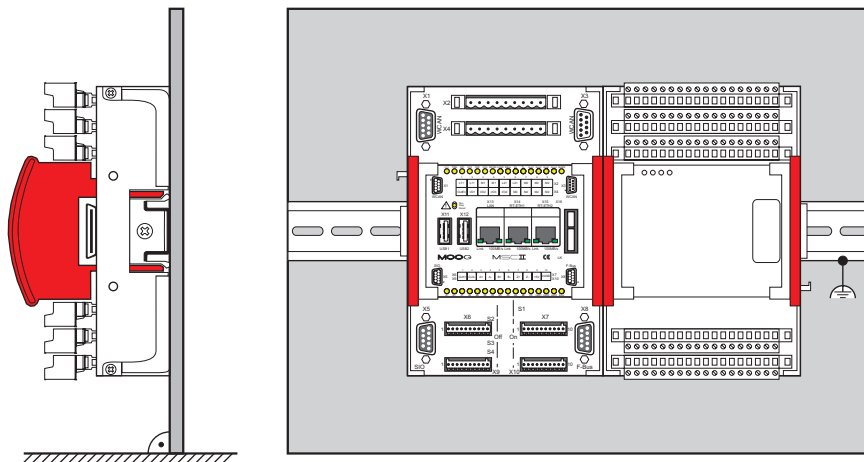

**Arrangement of
DIN Rail Modules on a
Vertical Mounting Plate**

Figure 17: Arrangement of DIN Rail Modules on a Vertical Mounting Plate

The DIN top-hat rail must be attached to a vertical, metal mounting plate and connected to the protective earth conductor.

Additional information about the grounding concept for DIN rail modules:

⇒ "6.1 Grounding Concept" on page 38

Information about mounting/removing DIN rail modules:

⇒ "5.1.4 Mounting and Removing" on page 33

Maintain the minimum distances shown in figure 18 on page 32 to ensure:

- Sufficient room for connecting the supply and signal cables
- Sufficient room for mounting or removing the DIN rail modules
- Convection cooling

If operational reasons force the selection of other arrangements, the performance ratings of the DIN rail modules will decrease or forced cooling measures will be needed.

Additional information about arranging DIN rail modules:

⇒ "7.7.2 E-Bus Groups" on page 65

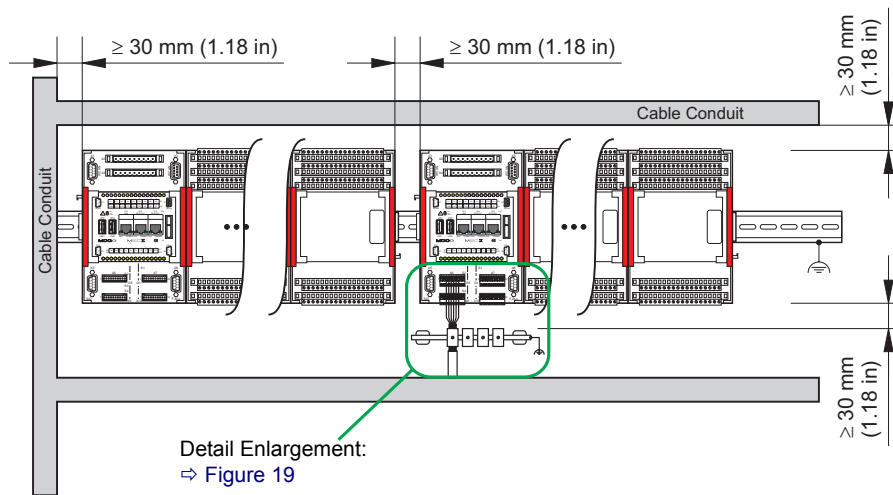

**Arrangement of
DIN Rail Modules
between Cable Conduits**

Figure 18: Arrangement of DIN Rail Modules between Cable Conduits

If shielding is required for the signal cables, make sure the distance between the DIN rail modules and the cable conduit is sufficiently large.

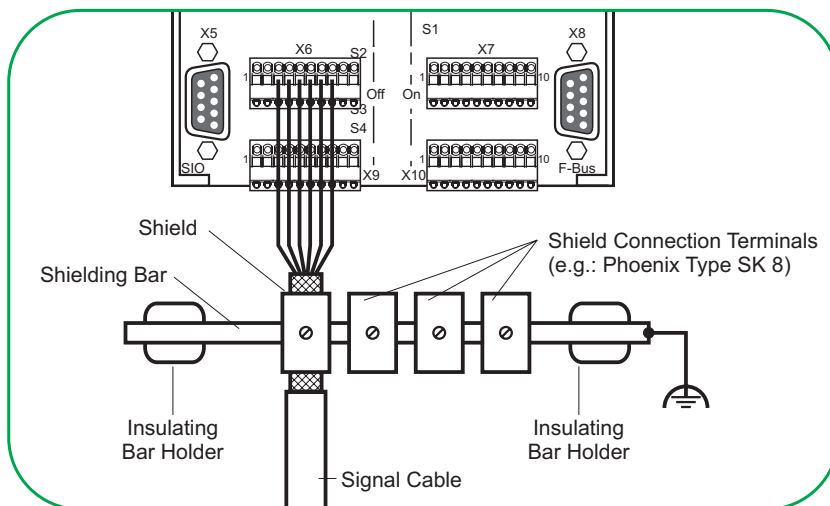

**Using a Shielding Bar
when Connecting a
Signal Cable to the
MSC II**

Figure 19: Using a Shielding Bar when Connecting a Signal Cable to the MSC II
(Detail from figure 18)

5.1.4 Mounting and Removing

5.1.4.1 Mounting DIN Rail Modules

WARNING



No work of any kind, such as mounting, removing, wiring, or repairs to the M3000[®] automation system or DIN rail modules may be performed while the automation system or the modules are in operation!

There is a danger of:

- Uncontrolled movements
- Permanent damage
- Malfunctions

Before performing any work on the M3000[®] automation system or DIN rail modules, it is essential that the system is stopped and the power supply is disconnected.

Therefore, all power supplies must be switched off, including those from attached peripherals such as externally supplied transmitters, programming devices, etc.!

Mounting
DIN Rail Modules:
Safety Instructions

No tools are needed to mount DIN rail modules.

Procedure for mounting DIN rail modules:

1. Unlock the module to be mounted by pulling out the two red locking slides.

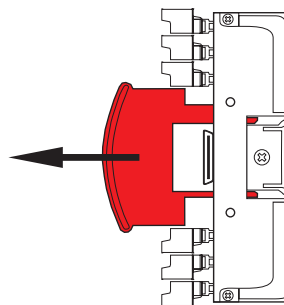

Figure 20: Unlocking a DIN Rail Module

2. If you wish to attach the module next to the right of a previously mounted DIN top-hat rail, then follow step 1 to also unlock the module that is already located on DIN top-hat rail.

Additional information about arranging the modules:

⇒ ["5.1.3 Arrangement on DIN Top-Hat Rails" on page 31](#)

⇒ ["7.7.2 E-Bus Groups" on page 65](#)

CAUTION



To avoid damaging the locating pins of the DIN rail modules, make sure the modules are at least 1 cm apart when placing them on the DIN top-hat rail.

Mounting
DIN Rail Modules

- Place the module to be mounted on the DIN top-hat rail and carefully push the module towards the DIN top-hat rail until the module engages.

i Do **not yet** push the red locking slides back into the module! If you do push them back in, you will no longer be able to slide the module on the DIN top-hat rail.

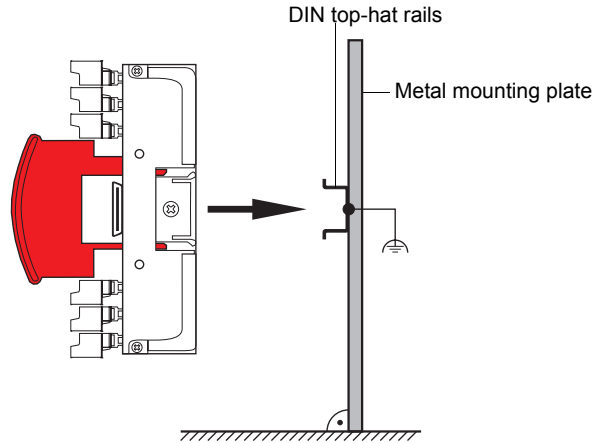

Figure 21: Placing a DIN Rail Module onto a DIN Top-Hat Rail

- Additional modules can be attached to the right as needed. Follow step 1 through step 3 to attach the additional modules.
- Slide the modules to the left on the DIN top-hat rail until the modules are joined **with no gaps**. This establishes contact between the Q-connectors and pushes the locating pins into their mating sockets.

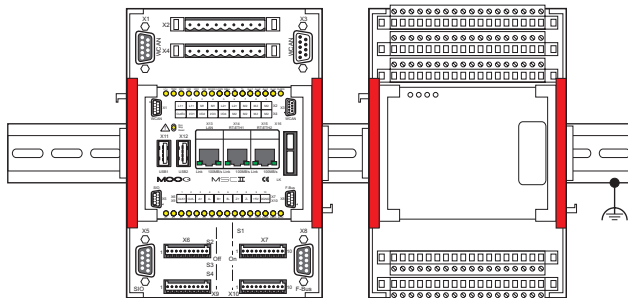

Figure 22: Sliding a DIN Rail Module on a DIN Top-Hat Rail

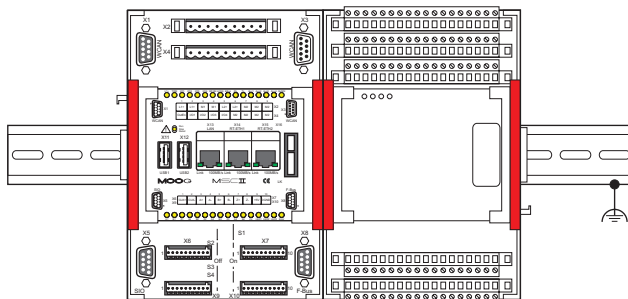

Figure 23: DIN Rail Modules Joined Without Gaps on a DIN Top-Hat Rail

Mounting DIN Rail Modules

6. Push the two red locking slides back into all of the modules. This fixes the modules onto the DIN top-hat rail, establishes an electrical connection with the top-hat rail, and locks the modules together with a secure contact.

Mounting DIN Rail Modules

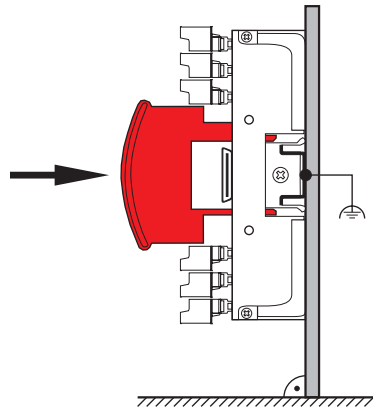

Figure 24: Fixing and Locking a DIN Rail Module

5.1.4.2 Removing DIN Rail Modules

WARNING



No work of any kind, such as mounting, removing, wiring, or repairs to the M3000[®] automation system or DIN rail modules may be performed while the automation system or the modules are in operation!

There is a danger of:

- Uncontrolled movements
- Permanent damage
- Malfunctions

Before performing any work on the M3000[®] automation system or DIN rail modules, it is essential that the system is stopped and the power supply is disconnected.

Therefore, all power supplies must be switched off, including those from attached peripherals such as externally supplied transmitters, programming devices, etc.!

Removing DIN Rail Modules: Safety Instructions

No tools are needed to remove DIN rail modules.

Procedure for removing DIN rail modules:**Removing
DIN Rail Modules**

1. Unlock the module to be removed and, if needed, adjacent modules, by pulling out the two red locking slides.

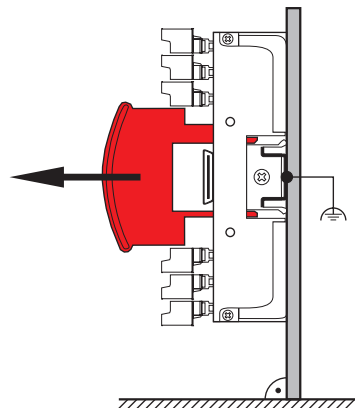

Figure 25: Unlocking a DIN Rail Module

2. Pull the modules at least 1 cm apart.

CAUTION

To avoid damaging the locating pins of the modules, make sure the DIN rail modules are at least 1 cm apart when removing them from the DIN top-hat rail.

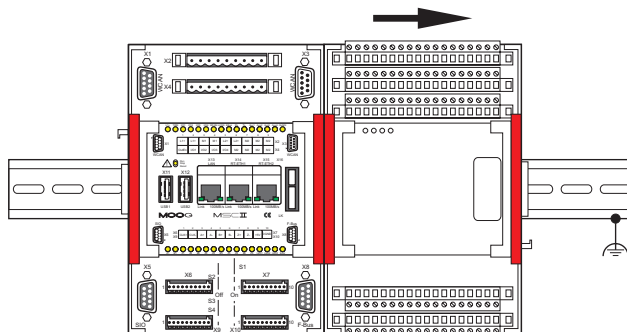

Figure 26: Pulling apart DIN Rail Modules

3. Lift off the module from the DIN top-hat rail.

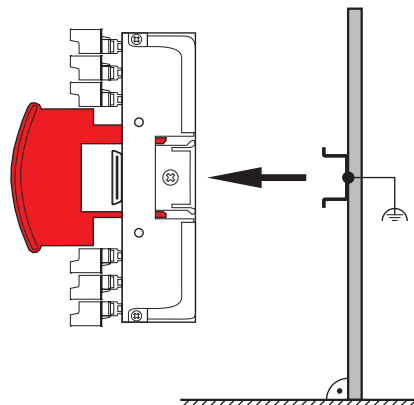

Figure 27: Lifting off a DIN Rail Module from the DIN Top-Hat Rail

6 Project Planning and Installation

The following instructions must be observed in order to ensure that the M3000[®] automation system will be safely integrated into its application environment:

Project Planning and Installation

- **IEC 61131**
Especially the information contained in IEC 61131-4
- **Safety**
All safety and accident prevention regulations applicable to the specific application (such as machinery directives, safety instructions contained in documentation, etc.)
- **Emergency stop**
The emergency stop devices (DIN EN 60204) must remain in effect during all of the system's or facility's operational modes.
- **Restarting**
Unlocking of the emergency stop devices must not lead to uncontrolled or undefined restarting.
Dangerous operational conditions of any kind must not arise following interruption or failure of the power supply.
- **Voltage**
Deviations and fluctuations of the supply and load voltages must not fall below or exceed the specified tolerances.
Deviations outside the specified operating range might lead to dangerous conditions and functional disturbances in the automation system.
- **Power supply 24 V DC**
M3000[®] modules must be supplied only with 24 V DC SELV (Safety Extra-Low Voltage) according to DIN EN 60950-1.
⇒ "6.2.1 Power Supply Characteristics" on page 39
- **Wire fault**
A cable or wire fault must not lead to undefined conditions. All necessary safety precautions must be taken in the hardware and software.
- **Connection**
All connection and signal cables must be installed in such a way that inductive or capacitive interferences will not impair the M3000[®] automation system.

6.1 Grounding Concept

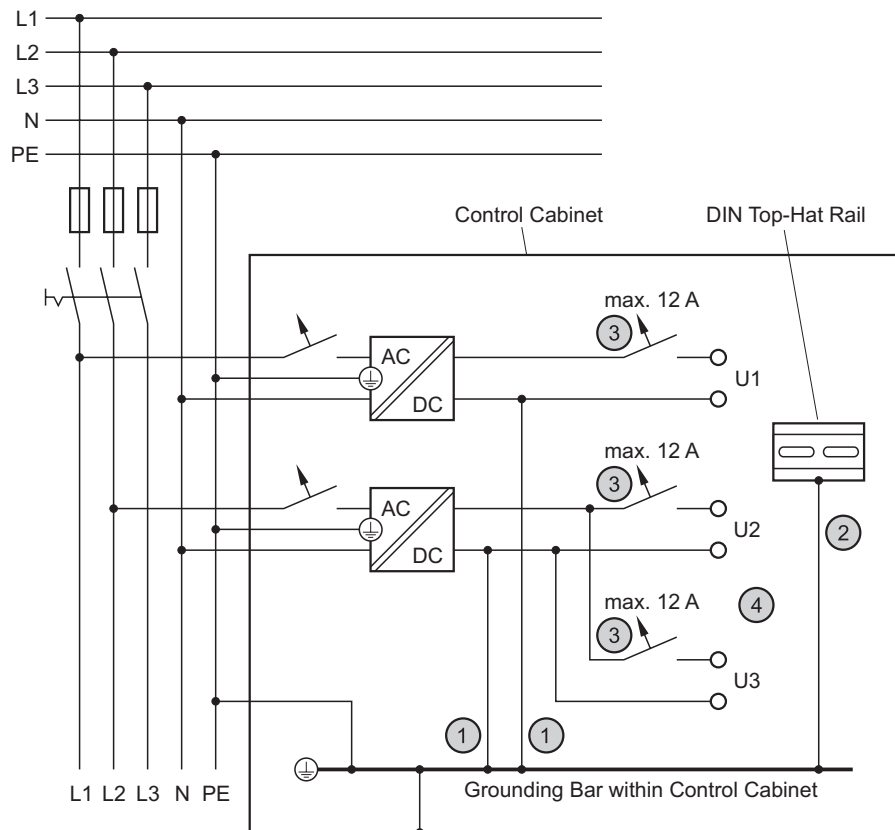

Figure 28: Grounding Concept

- ① For reasons of functional safety, all circuits must be grounded at a centralized point.
- ② The DIN top-hat rail must have a low resistance connection to the protective earth conductor (PE). It is essential that the DIN top-hat rail is grounded over a connection with the largest possible cross section.
- ③ Every circuit must be fused (maximum 12 A).
- ④ Load-controlled distribution of the circuits (U1...U3)

6.1.1 Front Panel Connectors' Grounding

The metal housings of all front panel connectors of the MSC II and the extension modules are connected internally to the grounding of the DIN top-hat rail.

Grounding Concept

Front Panel Connectors' Grounding

6.2 Power Supply

The internal electronics of M3000® modules is usually supplied with power via the power supply terminals of the connectors of the M3000® modules.

Connecting the power supply for the internal electronics:

⇒ "6.2.3 Connecting the Power Supply" on page 40

Power supply terminals of the MSC II:

⇒ "10.4.1 Terminal Assignment" on page 78

i Refer to the relevant documentation for the exact designations of the power supply terminals of the other M3000® modules.

Power Supply for M3000® Modules

6.2.1 Power Supply Characteristics

Output voltage

Rated voltage: 24 V DC, operates at no-load
SELV according to DIN EN 60950-1
⇒ "6.2.1.1 Safety Extra-Low Voltage (SELV)" on page 39

Run-up time (10–90 %): ≤ 0.2 sec.

i To ensure compatibility with other components, Moog recommends maintaining the power supply tolerance band specified in IEC 61131-2 (19.2 V to 30 V).

i Refer to the relevant documentation for the specified voltage ranges of the M3000® modules.

i Besides the specified voltage ranges, a total alternating voltage component with a peak value of 5 % of the rated voltage is also permitted.

Power Supply Characteristics of M3000® Modules

Output current

If the output current of the power supply is greater than 12 A, the power cable to each M3000® module must be fused to ≤ 12 A or the current must be limited in another way.

Maximum permissible duration of power interruptions

Under full load (PS1 intensity): ≤ 1 ms
(duration of interruption during voltage drops and interruptions to the input voltage)

i During primary side voltage drops that are 1 ms or shorter in duration, the output voltage must not fall under 19.2 V when under full load. In addition, the interval between the primary side drops must not be shorter than 1 s.

6.2.1.1 Safety Extra-Low Voltage (SELV)

The safety extra-low voltage is a voltage that will not, under any operating conditions, exceed 25 V AC or 60 V DC peak or direct voltage as measured between conductors or between a conductor and ground. The circuit in which SELV is used must be separated from the mains power supply by a safety transformer or something of equal functionality. Always observe national regulations when choosing the rated insulation voltage.

Safety Extra-Low Voltage (SELV)

6.2.2 Power Consumption

DIN Rail Module	Power Consumption ¹⁾	
	From 24 V DC (No-Load ²⁾)	From 24 V DC (Full Load)
MSC II	Internal Electronics	about 0.3 A
	Digital Outputs	-
RDIO	max. 0.3 A	max. 10 A
QDIO	-	max. 10 A
QAIO 16/4	about 0.15 A	max. 0.3 A

Table 2: Power Consumption

¹⁾ These values are provided only as guidelines for estimating the amount of current required. Refer to the relevant documentation for the exact power consumption by DIN rail modules.

²⁾ No-load, i.e., there are no loads, external to the module, drawing current.

Power Consumption

6.2.3 Connecting the Power Supply

DANGER



The 24 V power supply terminals of all M3000[®] modules are protected against reverse polarity. If the polarity of these power supply terminals is reversed, the modules will not work.

Connecting the Power Supply: Safety Instructions

WARNING



No work of any kind, such as mounting, removing, wiring, or repairs to the M3000[®] automation system or M3000[®] modules may be performed while the automation system or the modules are in operation!

There is a danger of:

- Uncontrolled movements
- Permanent damage
- Malfunctions

Before performing any work on the M3000[®] automation system or M3000[®] modules, it is essential that the system is stopped and the power supply is disconnected.

Therefore, all power supplies must be switched off, including those from attached peripherals such as externally supplied transmitters, programming devices, etc.!

WARNING



M3000[®] modules must be protected from overvoltages and/or reverse energization from the sensor to the module!

There is a danger of:

- Permanent damage by overheating or fire
- Malfunctions

M3000[®] modules must have the correct voltage, polarity, and terminal assignments.

WARNING

The internal electronics of M3000® modules and attached sensors must be supplied with power from a permanently connected (unswitched) power supply that cannot be individually switched off, without switching off the module's power supply.

If a switched power supply is used, such as when there are intermediate switching devices (emergency stops, manual operators, etc.), the following problems might arise, depending on the state of the power supply for the internal electronics of the module and sensors (⇒ [table 3 on page 41](#)):

- Reverse energization from sensor to module
- Invalid sensor data

	Power Supply	
	Internal Electronics	Sensors
Module and sensors are in operation	on	on
Reverse energization from sensor to module	off	on
Invalid sensor data	on	off
Module and sensors are not in operation	off	off

Power Supply for the Module's Internal Electronics and the Sensors

Table 3: Power Supply Conditions of the Module's Internal Electronics and the Sensors

Power supply terminals of the MSC II:

⇒ ["10.4.1 Terminal Assignment" on page 78](#)

- ① Refer to the relevant documentation for information about the power supply terminals of the other M3000® modules.
- ① Internal module capacities might cause power spikes of up to 50 A when switching on the power supply for the internal electronics of the M3000® module. The duration of these spikes is strongly dependent on the internal resistance of the power supply.

6.2.3.1 Connecting to Several Power Supplies

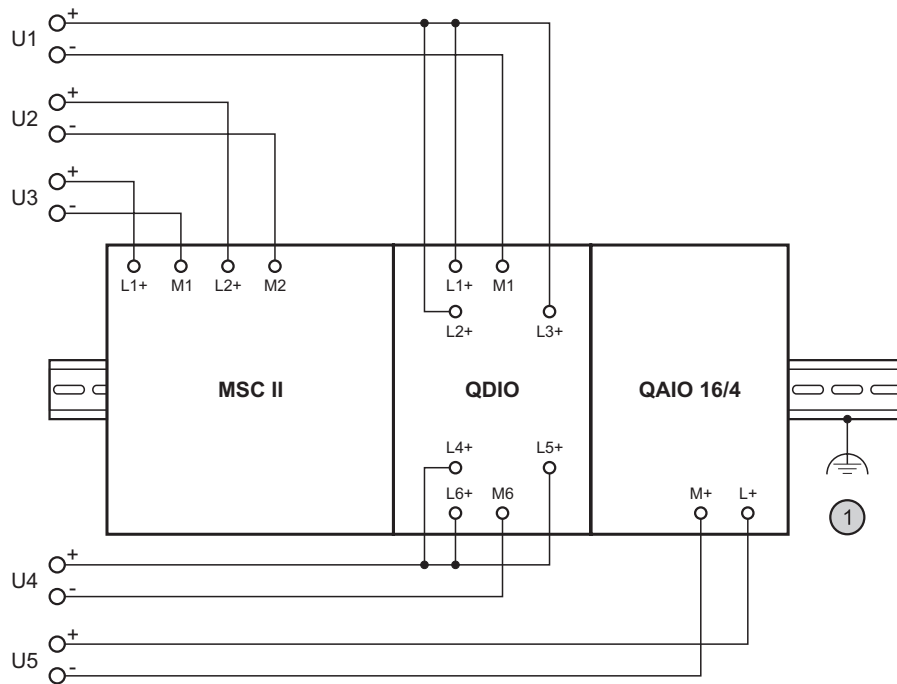

Correct Connection of
DIN Rail Modules to
Several Power Supplies

Figure 29: Correct Connection of DIN Rail Modules to Several Power Supplies

- ① DIN rail modules do not have any protective earth conductor terminals. However they are conductively connected to the DIN top-hat rail after they are engaged and locked onto it. The DIN rail modules thereby receive signal grounding. ⇒ ["6.1 Grounding Concept" on page 38](#)

6.2.3.2 Connecting to a Single Power Supply

Assuming that the power limits are observed, the internal electronics of DIN rail modules and the attached sensors may also be supplied from a single power supply.

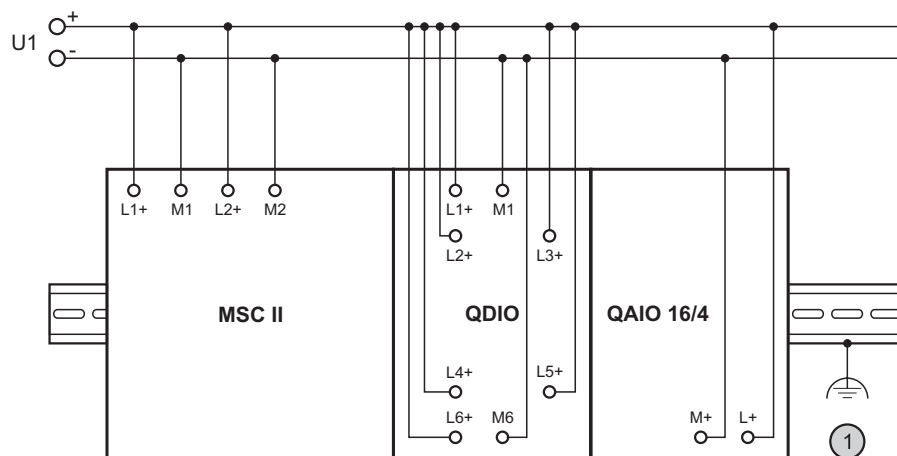

Correct Connection of
DIN Rail Modules to a
Single Power Supply

Figure 30: Correct Connection of DIN Rail Modules to a Single Power Supply

- ① DIN rail modules do not have any protective earth conductor terminals. However they are conductively connected to the DIN top-hat rail after they are engaged and locked onto it. The DIN rail modules thereby receive signal grounding. ⇒ ["6.1 Grounding Concept" on page 38](#)

6.2.3.3 Maximum Admissible Current

All of the power supply terminals of M3000[®] modules and the associated internal connections are designed for a maximum current of 12 A.

If the current is greater than the maximum current, the following must be employed:

- Several separately fused circuits or
- Several separate power supplies in separated circuits

Maximum Admissible Current for M3000[®] Modules

6.2.4 Connecting Sensors

WARNING



The internal electronics of M3000[®] modules and attached sensors must be supplied with power from a permanently connected (unswitched) power supply that cannot be individually switched off, without switching off the module's power supply.

If a switched power supply is used, such as when there are intermediate switching devices (emergency stops, manual operators, etc.), the following problems might arise, depending on the state of the power supply for the internal electronics of the module and sensors (⇒ table 3 on page 41):

- Reverse energization from sensor to module
- Invalid sensor data

Connecting Sensors: Safety Instructions

WARNING



Sensors that are connected to digital inputs of M3000[®] modules with several I/O groups, such as MSC I, QDIO, or RDIO, must under all conditions be supplied from the same power supply as the corresponding I/O group to which the sensor is connected!

Otherwise, if the power supply for the internal electronics of the module is switched off, there might be reverse energization from the sensor to the module.

There is a danger of:

- Uncontrolled movements
- Fault or failure of a manual control
- Permanent damage to the module
- Malfunctions

Digital I/Os of MSC II and MSD Motion Controller are protected against reverse energization.

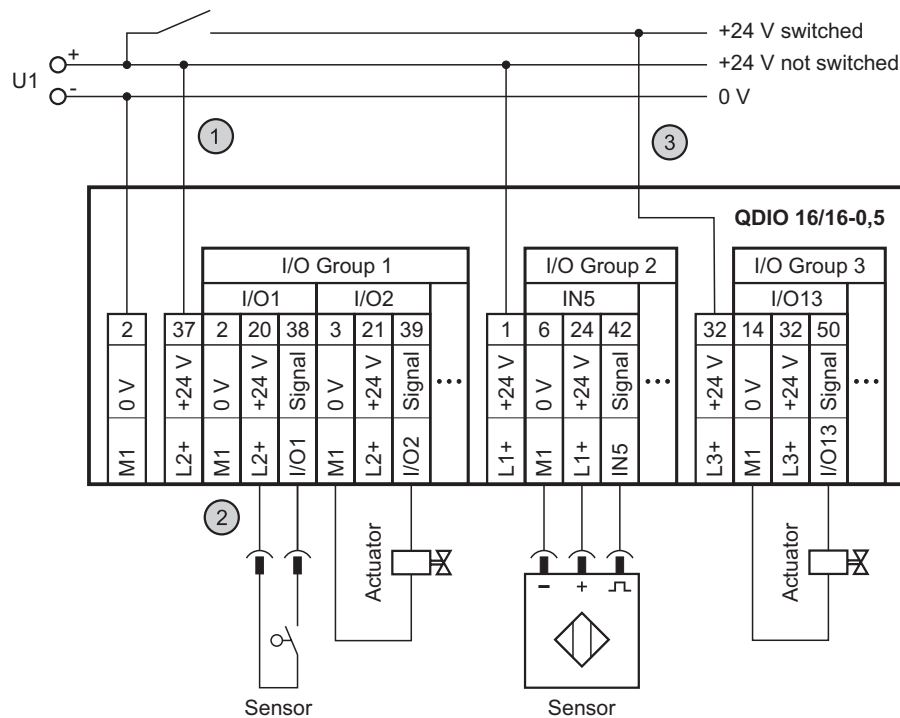

Correct Power Supply Connection of Sensors via a QDIO

Figure 31: Correct Power Supply Connection of Sensors via a QDIO

- ① The attached sensors must be supplied with power from a permanently connected (unswitched) power supply that cannot be individually switched off, without switching off the module's power supply. Power must not, as shown in [figure 32 on page 45](#), be supplied from switched power circuits!
- ② The sensors within an I/O group must always be supplied with power from the same power supply that supplies the relevant I/O group. They must not, as shown in [figure 32 on page 45](#), be supplied from a separate power supply (due to the danger of reverse energization)!
- ③ Outputs may be supplied with power from a switched power supply, for example with intermediate devices (emergency stop, manual operation, etc.).

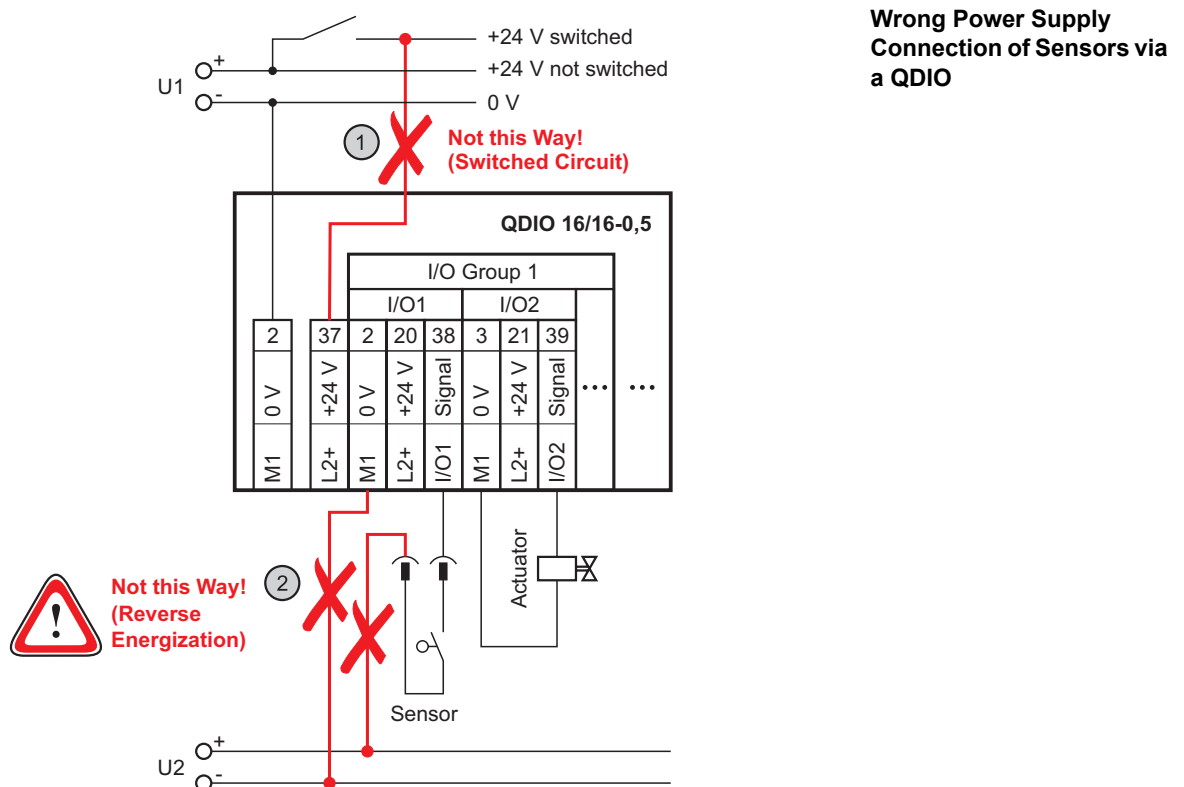

Figure 32: Wrong Power Supply Connection of Sensors via a QDIO

- ① The attached sensors must be supplied with power from a permanently connected (unswitched) power supply that cannot be individually switched off, without switching off the module's power supply. Power must not, as shown here, be supplied from switched power circuits!
- ② The sensors within an I/O group must always be supplied with power from the same power supply that supplies the relevant I/O group. They must not, as shown here, be supplied from a separate power supply (due to the danger of reverse energization)!

6.3 Connecting Signal Cables

WARNING



No work of any kind, such as mounting, removing, wiring, or repairs to the M3000[®] automation system or M3000[®] modules may be performed while the automation system or the modules are in operation!

There is a danger of:

- Uncontrolled movements
- Permanent damage
- Malfunctions

Before performing any work on the M3000[®] automation system or M3000[®] modules, it is essential that the system is stopped and the power supply is disconnected.

Therefore, all power supplies must be switched off, including those from attached peripherals such as externally supplied transmitters, programming devices, etc.!

The signal cables of M3000[®] modules are connected over plug-in terminal strips that are inserted into the relevant connectors on the front of the module.

6.3.1 Plug-In Terminal Strips

Plug-in terminal strips for the following methods are available from Moog:

- Screw terminals
- Spring loaded terminals

All plug-in terminal strips are suitable for wire cross sections of up to 2.5 mm² (14 AWG).

⇒ "11.8 Plug-In Terminal Strips" on page 121

6.3.1.1 Spring Loaded Terminals

CAUTION



When connecting a wire, insert the screwdriver only into the rectangular opening of the spring loaded terminal. If a screwdriver is inserted into the round opening for the wire, the spring loaded terminal might be destroyed.

Spring loaded terminals make it easy to rapidly connect supply and signal cables.

Procedure for connecting a wire:

1. Insert the tip of a screwdriver into the rectangular opening of the spring loaded terminal and press the screwdriver downward.
2. Insert the wire into the corresponding round opening.
3. Remove the screwdriver from the opening.
The spring will hold the wire in place.

**Connecting Signal Cables:
Safety Instructions**

**Connecting Signal Cables
over Plug-In Terminal
Strips**

**Connection Methods for
Plug-In Terminal Strips
of M3000[®] Modules**

Spring Loaded Terminals

7 Networking M3000® Modules

7.1 Ethernet

WARNING



Do not connect EtherCAT to any other Ethernet networks. The high rate of telegrams which are transmitted by EtherCAT will prevent other devices like computers and servers on the network from transmitting data.

There is a danger of

- Network overload/breakdown
- Malfunction of connected devices
- Data loss at connected devices

It is strongly recommended to use cables of a special color only for EtherCAT connections.

Refer to the following for information about using the Ethernet interface to facilitate communication between the MSC II control module and the MACS development environment:

⇒ "3.1 M3000® System Architecture" on page 14

⇒ "10.5.1 Communication Between MSC II and MACS" on page 84

⇒ "10.5.1.1 Ethernet Communication Interface" on page 84

7.1.1 Peer-to-Peer Connections

To establish a peer-to-peer connection between 2 stations in an Ethernet network, 100BaseT cables with twisted pair wires are needed.

⇒ Figure 35 on page 48

Peer-to-Peer Connection of 2 Network Stations

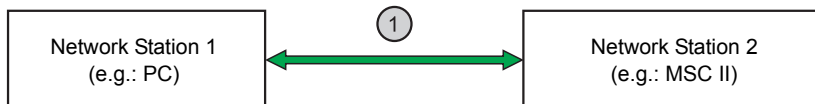

Figure 33: Ethernet Network with exactly 2 Network Stations

- ① • 100BaseT patch or crossover cable with twisted pair wires for MSC II and MSD Motion Controller
- 10BaseT crossover cable with twisted pair wires for MSC I

7.1.2 Networking of More Than 2 Network Stations

A hub or switch is needed for Ethernet networks that have more than 2 stations. The hub transfers the signals sent from one of the stations to every other station in the network.

Ethernet Network with more than 2 Network Stations

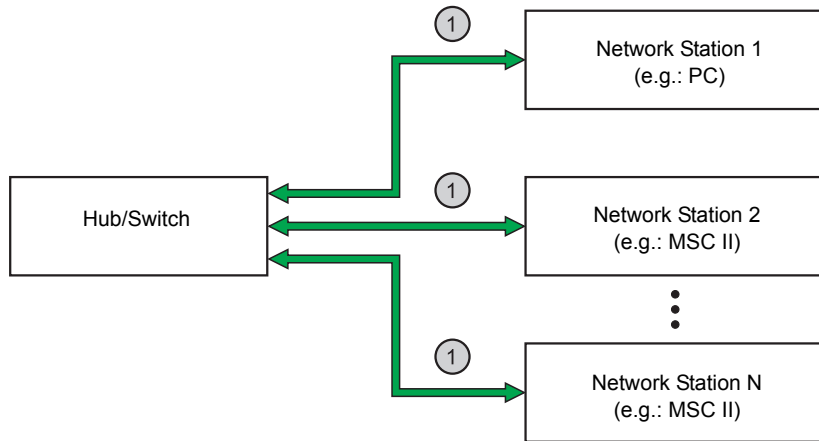
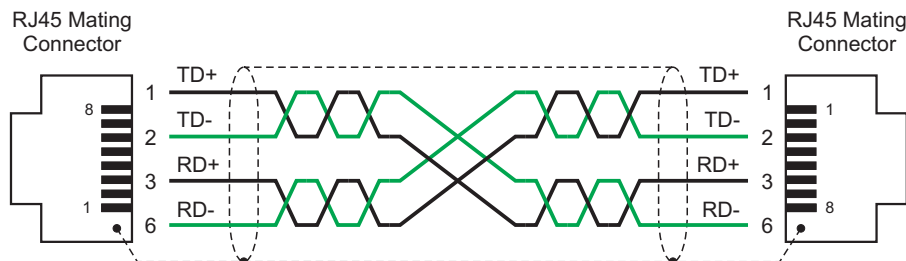

Figure 34: Ethernet Network with more than 2 Network Stations

- ① • 100BaseT patch or crossover cable with twisted pair wires for MSC II and MSD Motion Controller
- 10BaseT patch cable with twisted pair wires for MSC I

7.1.3 Ethernet Interface Cables



100BaseT Cable with Crossed Twisted Pair Wires (Crossover Cable)

Figure 35: 100BaseT Cable with Crossed Twisted Pair Wires (Crossover Cable) with 8 Pole RJ45 Mating Connectors, Cable Category 5, Wire Cross Section > 0.22 mm² (24 AWG)

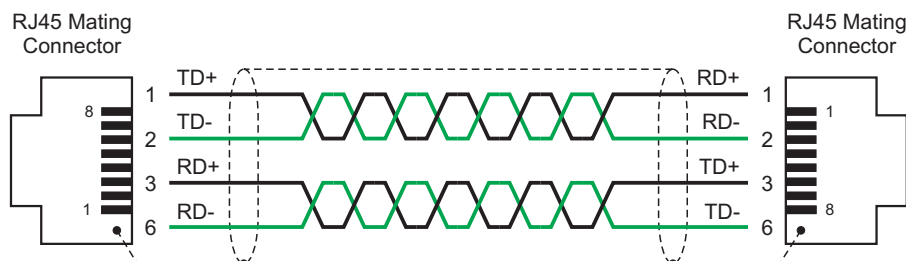

100BaseT Cable with Non-Crossed Twisted Pair Wires (Patch Cable)

Figure 36: 100BaseT Cable with Non-Crossed Twisted Pair Wires (Patch Cable) with 8 Pole RJ45 Mating Connectors, Cable Category 5, Wire Cross Section > 0.22 mm² (24 AWG)

For the terminal assignment of the Ethernet front panel connector of the MSC II control module, see: ⇒ [Ethernet connector on page 80](#)

7.2 EtherCAT

WARNING



Do not connect EtherCAT to any other Ethernet networks. The high rate of telegrams which are transmitted by EtherCAT will prevent other devices like computers and servers on the network from transmitting data.

There is a danger of

- Network overload/breakdown
- Malfunction of connected devices
- Data loss at connected devices

It is strongly recommended to use cables of a special color only for EtherCAT connections.

Technical data:

- 100 Mbit/s transfer rate
- Maximal cable length between two devices: 100 m
- Termination: device internally

7.2.1 Bus Topology

The network physical topology is line.

The connection between two devices is a point to point connection. Thus each slave device has an input and an output connector which relays the data to the next slave device in the line.

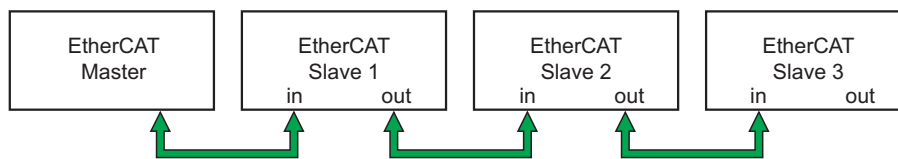

Figure 37: EtherCAT Bus Topology

7.2.2 EtherCAT Interface Cables

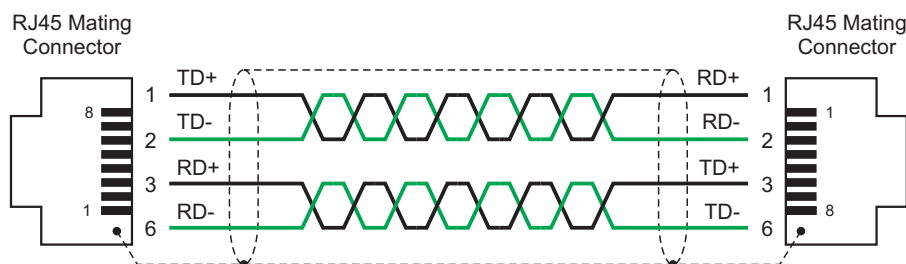

Figure 38: 100BaseT Cable with Non-Crossed Twisted Pair Wires (Patch Cable) with 8 Pole RJ45 Mating Connectors, Cable Category 5, Wire Cross Section > 0.22 mm² (24 AWG)

For the terminal assignment of the EtherCAT front panel connector of the MSC II control module, see: ⇒ [EtherCAT connector on page 81](#)

EtherCAT

Bus Topology

EtherCAT Bus Topology

100BaseT Cable with Non-Crossed Twisted Pair Wires (Patch Cable)

7.3 Profibus

7.3.1 Overview

The Profibus is a differential two wire bus. The transmission physics of the serial bus system is defined by the TIA/EIA-485 specification. Shielded twisted pair copper cable with one conductor pair is typically used. The bus structure allows addition or removal of stations or the step-by-step commissioning of the system without influencing other stations.

- Various transmission rates
- Uniform speed for all devices on the bus
- Connection of up to 32 stations without additional repeater possible

Overview

7.3.2 M3000® Modules with Profibus DP Interfaces

Information about the Profibus interface cable:

⇒ ["7.3.4 Profibus Interface Cable" on page 52](#)

Information about the Profibus interface of the MSC II:

⇒ ["10.11 Profibus DP Interface" on page 100](#)

The M3000® modules mentioned here represent only a part of Moog's current product range. In addition to other M3000® modules, Moog's product range includes a large variety of accessories.

⇒ ["11 Product Range" on page 114](#)

Refer to the relevant documentation for detailed information about the Profibus interfaces of the other M3000® modules.

M3000® Modules with Profibus DP Interfaces

7.3.3 Profibus Networks

7.3.3.1 Wiring

Always observe the following when wiring Profibus networks:

- **EC 61158/EN 50170**
The cables, mating connectors, and termination resistors used in Profibus networks must comply with IEC 61158/EN 50170. It is recommended to use only connections of cable type A, to use the full bandwidth of 12 Mbaud.
- **Specifications for interface cables**
⇒ ["7.3.4.4 Suitable Cables" on page 53](#)
- **Linear structure of Profibus**
Avoid branching. Short stub cables with a T-adapter or special Profibus connectors with internal T-adapter are permitted.
⇒ ["7.3.3.2 Bus Structure of the Profibus" on page 51](#)
- **Stub cables as short as possible**
Maximum length of all stub cables < 6.6 m at baud rates < 1500 kbit/s. No stub cables recommended at higher baud rates.
- **Profibus termination resistors**
At both ends of the Profibus network, termination resistors must be connected to guarantee specified signal levels.
- **Adapt transmission rate to cable length**
It is necessary to adapt the transmission rate to the length of the Profibus interface cable.
⇒ ["7.3.4.3 Cable Lengths" on page 53](#)

Wiring Profibus Networks

- **Sources of interference**

Do not lay Profibus interface cables in direct proximity to sources of interference.

7.3.3.2 Bus Structure of the Profibus

All devices are connected in a linear bus structure. Up to 32 stations (master or slaves) can be connected in a single segment. The beginning and the end of each segment is fitted with an active bus terminator. Both bus terminators have a permanent power supply to ensure error-free operation. The bus terminator is usually switched in the connectors. If more than 32 stations are implemented or there is a need to expand the network area, repeaters must be used to link the individual bus segments.

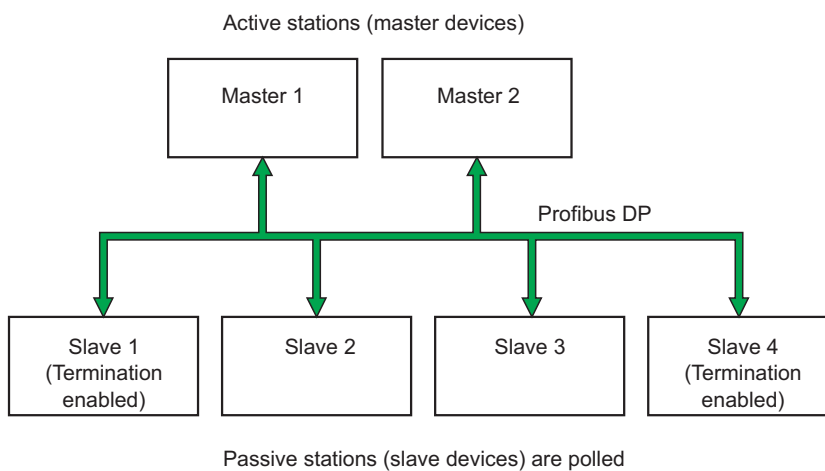

Figure 39: Linear Structure of the Profibus with Termination Resistors

Linear Structure of the Profibus with Termination Resistors

D-sub connectors with Profibus termination resistors are available from Moog.

Profibus networks with M3000® modules can include a maximum of 126 Profibus network stations.

⇒ ["7.3.3.3 Number of Network Stations" on page 51](#)

Profibus interface cable

⇒ ["7.3.4 Profibus Interface Cable" on page 52](#)

7.3.3.3 Number of Network Stations

Profibus networks with M3000® modules can only include a maximum of 32 Profibus network stations. With repeater stations the network can be expanded to a maximum of 126 stations within the address range of 0 to 125. Each repeater reduces the maximum number of network stations, as a repeater is a passive network station without any address.

IEC 61158/EN 50170 specifies networks with up to 126 Profibus network stations. The performance to the Profibus master may limit the maximum number of slaves. The number of network stations also influences the reaction time that can be achieved by the bus.

Number of Network Stations

7.3.4 Profibus Interface Cable

7.3.4.1 Terminal Assignment

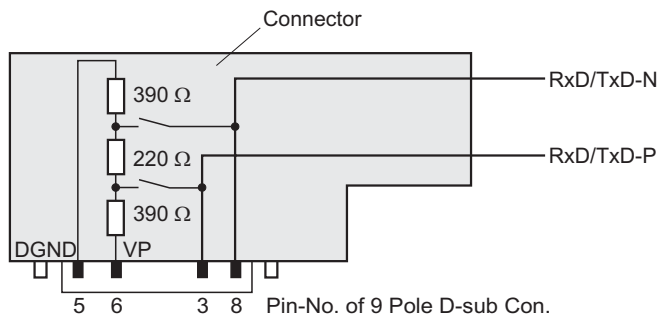

Figure 40: 9 Pole D-sub Mating Connector with switchable termination according to IEC 61158/EN 50170

9 Pole D-sub Mating Connector with switchable termination according to IEC 61158/EN 50170

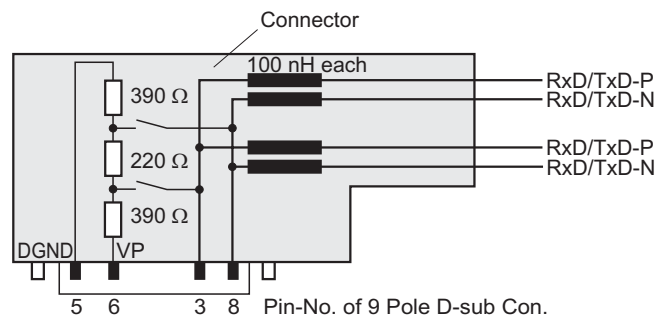

Figure 41: Profibus Interface - Connector with internal longitudinal inductivity according to IEC 61158/EN 50170

Profibus Interface - Connector with internal longitudinal inductivity according to IEC 61158/EN 50170

Terminal assignment of the Profibus connectors on the front panel of the MSC II control module: ⇒ ["10.4.1 Terminal Assignment" on page 78](#)

7.3.4.2 Connector Pin out

Pin No.	Signal	Function
1	Shield	Shield / grounding
2	M24	24 V output voltage (ground)
3	RxD/TxD-P ¹⁾	Receive / transmission data - positive potential
4	CNTR-P	Control signal for repeater (direction control)
5	DGND	Potential of transmission data (ground to 5 V)
6	VP	Power supply of the terminators (+5 V)
7	P24	24 V output voltage
8	RxD/TxD-N ¹⁾	Receive / transmission data - negative potential
9	CNTR-N	Control signal for repeater (direction control)

Table 4: Connector Pin out

¹⁾ These signals are mandatory and must be provided by the user.

Connector Pin out

7.3.4.3 Cable Lengths

Transmission Rate	Maximum Cable Length
12,000 kBit/s	100 m (109 yd)
6,000 kBit/s	100 m (109 yd)
3,000 kBit/s	100 m (109 yd)
1,500 kBit/s	200 m (219 yd)
500 kBit/s	400 m (437 yd)
187.5 kBit/s	1,000 m (1,094 yd)
93.75 kBit/s	1,200 m (1,312 yd)
45.45 kBit/s	1,200 m (1,312 yd)
19.2 kBit/s	1,200 m (1,312 yd)
9.6 kBit/s	1,200 m (1,312 yd)

Maximum Cable Lengths in Profibus Networks

Table 5: Maximum Cable Lengths in Profibus Networks (Depending on the Transmission Rate)

 The guiding values in [table 5](#) are valid only for Profibus networks that were established in compliance with the requirements in "[7.3.3.1 Wiring](#)" on [page 50](#).

Transmission Rate	Maximum Stub Cable Length
12,000 kBit/s	no stub cable allowed
1,500 kBit/s	< 1.5 m
500 kBit/s	< 6.6 m

Permissible Stub Cable Lengths in Profibus Networks

Table 6: Maximum Permissible Stub Cable Length in Profibus Networks (Depending on the Transmission Rate)

7.3.4.4 Suitable Cables

Parameters	Cable Type A
Loop resistance at 3-20 MHz	135-165 Ω (150 Ω \pm 10 %)
Capacity	< 30 pF/m
Impedance	< 110 Ω /km
Wire diameter	> 0.64 mm
Wire Cross Section	> 0.34 mm ²

Suitable Cables for Profibus Interface Cables

Table 7: Suitable Cables for Profibus Interface Cables

The selection of a suitable cable also depends on site conditions (towing application, environmental considerations, etc.)

7.4 Serial TIA/EIA Interface Cables

The following variants of serial TIA/EIA interface cables are possible:

- **Null modem cables**
⇒ "7.4.1 TIA/EIA 232 Interface Cables" on page 54
- **Interface cables with 1:1 connection**
For example: when connecting terminals or displays
⇒ "7.4.1 TIA/EIA 232 Interface Cables" on page 54

Serial TIA/EIA Interface Cables

7.4.1 TIA/EIA 232 Interface Cables

A TIA/EIA 232 null modem cable can be used as a cable to connect the MSC II and PC.

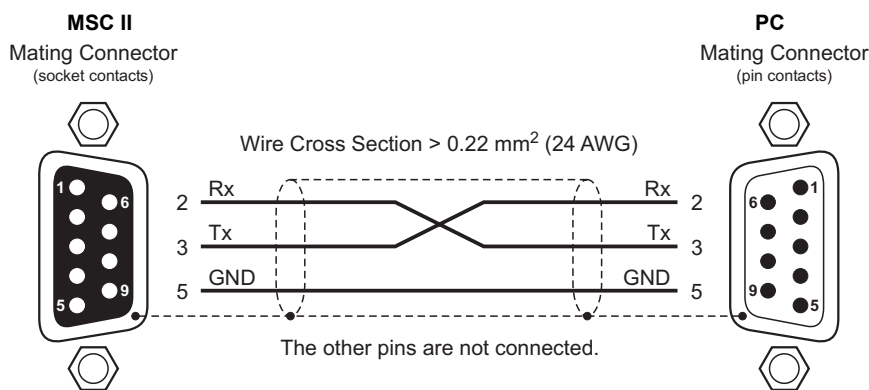

TIA/EIA 232 Null Modem Cable

Figure 42: TIA/EIA 232 Null Modem Cable with 9 Pole D-sub Mating Connectors according to DIN 41652

TIA/EIA interface cables with 1:1 connection can be used to connect terminals or displays.

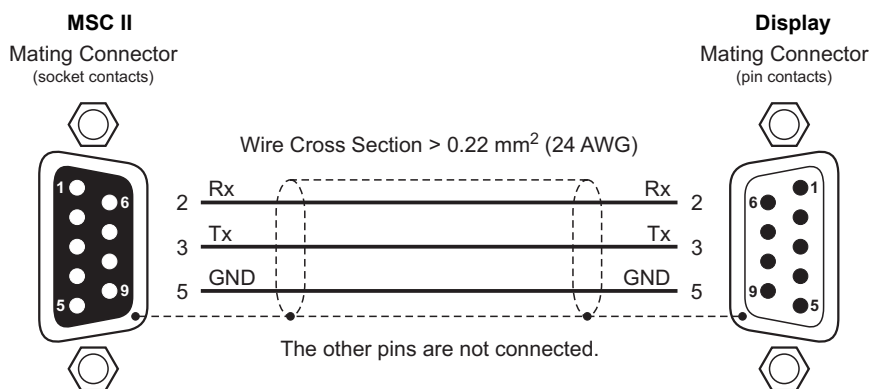

TIA/EIA 232 Interface Cable with 1:1 Connection

Figure 43: TIA/EIA 232 Interface Cable with 1:1 Connection with 9 Pole D-sub Mating Connectors according to DIN 41652

7.5 CAN Bus and CANopen

7.5.1 CAN Bus

The CAN bus is a differential two wire bus that was originally developed to facilitate rapid and reliable networking of components in motor vehicles.

The many advantages and high reliability of the CAN bus have also made it suitable for use in automation systems and have contributed to it becoming a widespread standard.

CAN Bus

7.5.2 CAN Bus Characteristics

CAN bus exhibits the following characteristics:

- Linear topology that can be structured hierarchically
- Message oriented protocol
- Prioritization of messages
- Multi master capability
- Zero loss bus arbitration
- Short block length
- High security of data transmission with very short error recovery times
- Network data consistency
- Detection and disconnection of defective network stations
- Short reaction time for high priority messages
- Standardization (ISO/DIS 11898)
- Cost effective protocol implementation

CAN Bus Characteristics

CAN bus network stations can exchange messages between each other in real time over the CAN bus. For example, set points, actual values, control messages, status messages, as well as configuration and parameter data can be transmitted over the CAN bus.

Identifiers act as message labels in the CAN protocol. The messages can be received by all network stations simultaneously, which is very important for consistency of the data in the network and synchronization of the applications. The identifier determines the message's bus access priority.

CAN bus is a multi master system, i.e., every station in the network can send messages. If several stations attempt to send messages at the same time, the highest priority messages will be sent first. This method guarantees bus assignment without destroying the contents of the messages.

7.5.3 CANopen

CANopen is a standardized communication profile that makes it easy to establish a network of CANopen compatible devices from a variety of manufacturers.

CANopen is based on CAN bus. The communication profile complies with the standard CiA DS 301.

Various device profiles have been defined by the CiA in order to facilitate the connection of various device classes, such as drives, controllers, angle transmitters, valves, etc. These device profiles enable uniform control of several devices with the same functionality, regardless of manufacturer and model.

CANopen

CANopen Device Profiles

7.5.4 M3000® Modules with CAN Bus Interfaces

M3000® Module	Number of Connectors	Number of CAN Bus Controllers	CAN Bus Termination Resistor
MSD Motion Controller CAN	2 D-sub front panel connectors ¹⁾	1	-
MSC I and MSC II	LocalCAN	2 Q-connectors (lateral)	switchable
	WideCAN	2 D-sub front panel connectors ²⁾	-
RDIO	2 D-sub front panel connectors ²⁾	1	-
RDISP	1 D-sub connector (on the rear)	1	switchable
QEBUS-CAN	LocalCAN	1 Q-connector (lateral)	switchable
		1 D-sub connector (front)	

M3000® Modules with CAN Bus Interfaces

Table 8: M3000® Modules with CAN Bus Interfaces

¹⁾ The «WCAN» front panel connectors are connected internally 1:1 with each other. As a result, the MSC II control module can be connected directly to the CAN bus without a T-adapter.

²⁾ The «WCAN» or «CAN» front panel connectors are connected internally 1:1 with each other. As a result, the M3000® modules can be connected directly to the CAN bus without a T-adapter.

- i** The M3000® modules mentioned here represent only a part of Moog's current product range. In addition to other M3000® modules, Moog's product range includes a large variety of accessories.
 ⇒ "11 Product Range" on page 114

Information about the CAN bus interface cable:

⇒ "7.5.6 CAN Bus Interface Cable" on page 59

Information about the CAN bus interfaces of the MSC II:

⇒ "10.15 CAN Bus Interfaces" on page 109

- i** Refer to the relevant documentation for detailed information about the CAN bus interfaces of the other M3000® modules.

7.5.5 CAN Bus Networks

7.5.5.1 Wiring

Always observe the following when wiring CAN bus networks:

Wiring CAN Bus Networks

- **ISO/DIS 11898**
The cables, mating connectors, and termination resistors used in CAN bus networks must comply with ISO/DIS 11898.
- **Specifications for interface cables**
When connecting CAN bus network stations, always use shielded cables with 4 twisted pair wires and an impedance of 120 Ω.
⇒ "7.5.6 CAN Bus Interface Cable" on page 59
- **Linear structure of CAN bus**
Avoid branching. Short stub cables with a T-adapter are permitted.
⇒ "7.5.5.2 Bus Structure of the CAN Bus" on page 58
- **Stub cables as short as possible**
Maximum stub cable length: ⇒ table 10 on page 59
- **CAN bus termination resistors**
At both ends of the CAN bus, a termination resistor of 120 Ω ± 10 % must be connected between CAN_L and CAN_H.
- **Adapt transmission rate to cable length**
It is necessary to adapt the transmission rate to the length of the CAN bus interface cable.
⇒ Table 9 on page 59
- **Sources of interference**
Do not lay CAN bus interface cables in direct proximity to sources of interference. If this cannot be avoided, double shielded interface cables must be used.
- **Potential equalization at only one point**
The CAN_GND and CAN_SHLD reference potential may be connected to the signal ground at only one point (at a CAN bus termination resistor, for example).
⇒ Figure 44 on page 58
- **Grounding**
The power supply for M3000® modules must be grounded at the same point as the CAN_GND wire.

7.5.5.2 Bus Structure of the CAN Bus

The CAN bus has a linear structure. Avoid branching. Short stub cables with a T-adaptor are permitted.

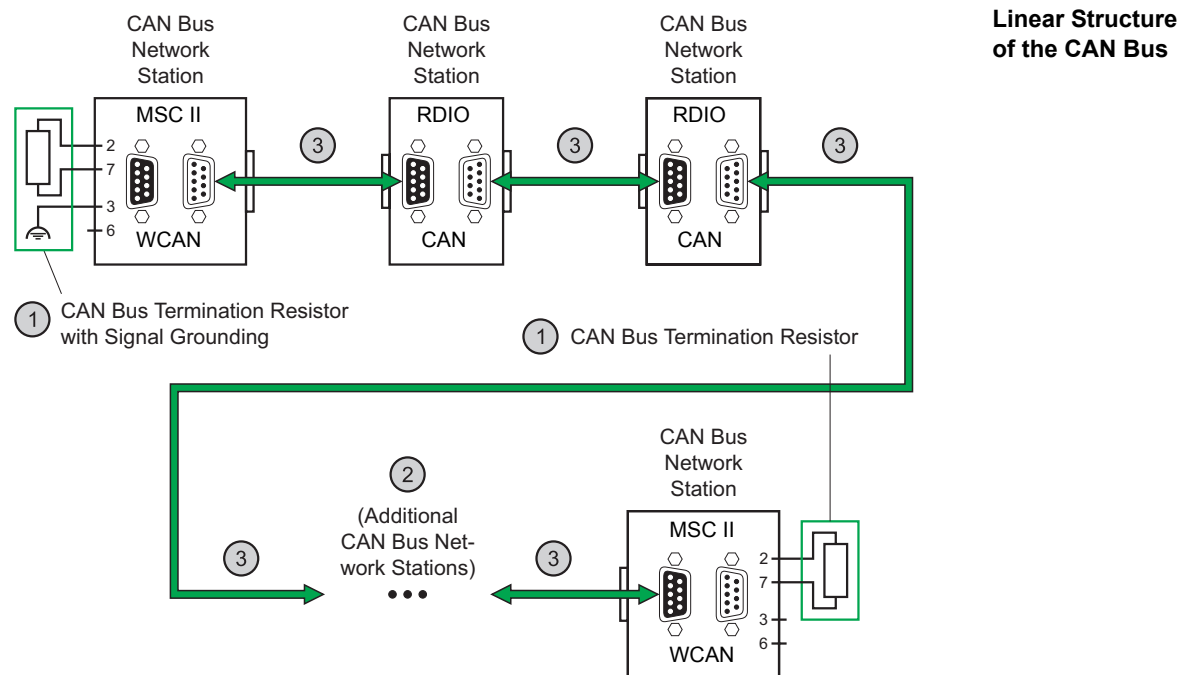

Figure 44: Linear Structure of the CAN Bus with CAN Bus Termination Resistors and Potential Equalization

- ① D-sub connectors with CAN bus termination resistors are available from Moog.
⇒ ["11.7 CAN Bus Accessories" on page 120](#)
- ② CAN bus networks with M3000® modules can include a maximum of 64 CAN bus network stations.
⇒ ["7.5.5.3 Number of Network Stations" on page 58](#)
- ③ CAN bus interface cable
⇒ ["7.5.6 CAN Bus Interface Cable" on page 59](#)

7.5.5.3 Number of Network Stations

CAN bus networks with M3000® modules can include a maximum of 64 CAN bus network stations.

ISO/DIS 11898 only specifies networks with up to 30 CAN bus network stations.

As a result, when integrating other devices than M3000® modules into a CAN bus network with M3000® modules, the maximum number of CAN bus network stations might be limited by any existing, older CAN bus drivers.

**CAN Bus Networks with M3000® Modules:
max. 64 Network Stations**

7.5.6 CAN Bus Interface Cable

7.5.6.1 Terminal Assignment

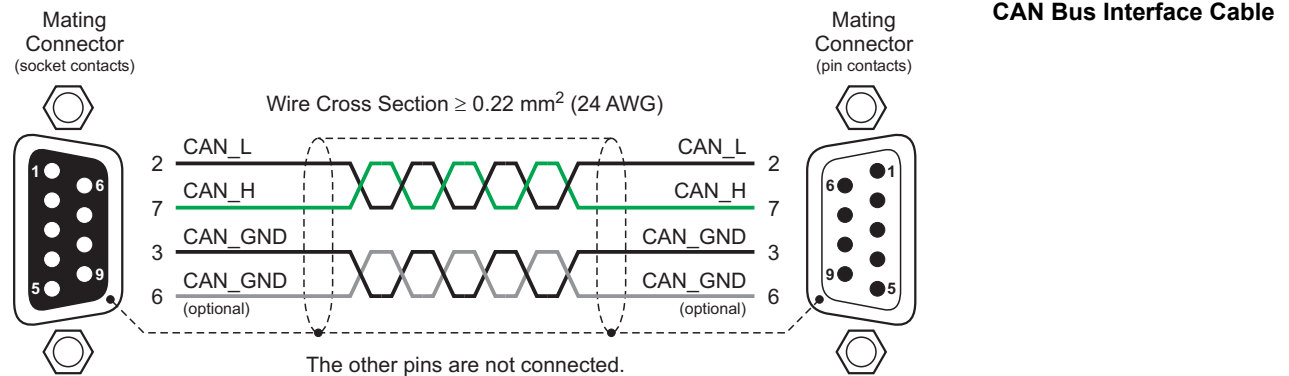

Figure 45: CAN Bus Interface Cable
with 9 Pole D-sub Mating Connectors according to DIN 41652

To ensure disturbance-free operation, it is required that a CAN_GND wire is used in the cable.

Terminal assignment of the CAN connectors on the front panel of the MSC II control module: ⇒ "10.4.1 Terminal Assignment" on page 78

7.5.6.2 Cable Lengths

The maximum expansion of a CAN bus network will be determined by a variety of variables, such as cable length, transmission rate, and resistance in the cable.

Transmission Rate	Maximum Cable Length
1,000 kBit/s	25 m (27 yd)
800 kBit/s	50 m (54 yd)
500 kBit/s	100 m (109 yd)
250 kBit/s	250 m (273 yd)
125 kBit/s	500 m (546 yd)
100 kBit/s	650 m (710 yd)
50 kBit/s	1,000 m (1,093 yd)
20 kBit/s	2,500 m (2,734 yd)
10 kBit/s	5,000 m (5,468 yd)

Table 9: Maximum Cable Lengths in CAN Bus Networks (Depending on the Transmission Rate)

Maximum Cable Lengths in CAN Bus Networks

Transmission Rate	Maximum Stub Cable Length	
	Maximum	Cumulated
1,000 kBit/s	2 m (2.1 yd)	20 m (21.8 yd)
500 kBit/s	6 m (6.5 yd)	39 m (42.6 yd)
250 kBit/s	6 m (6.5 yd)	78 m (85.3 yd)
125 kBit/s	6 m (6.5 yd)	156 m (170.6 yd)

Table 10: Maximum Permissible Stub Cable Lengths in CAN Bus Networks

Permissible Stub Cable Lengths in CAN Bus Networks

i The guiding values in tables 9 and 10 are valid only for CAN bus networks that were established in compliance with the requirements in "7.5.5.1 Wiring" on page 57.

7.5.6.3 Suitable Cables

Parameters	M3000® Recommendation	Remarks
Number of Wires	≥ 4, twisted pairs	
Wire Cross Section (for Cu)	0.22–0.34 mm ² (24–22 AWG)	When the network is spread out over a greater distance, a larger wire cross section will provide a better signal-to-noise ratio.
Cable Structure	2 twisted pairs with shielding	Electrically connect the shield to the mating connector's housing and the shielding shroud of the plug-in devices.
Impedance (1 MHz)	120 Ω	If different cables are used, make sure they have the same impedance.

Suitable Cables for CAN Bus Interface Cables

Table 11: Suitable Cables for CAN Bus Interface Cables

The selection of a suitable cable also depends on site conditions (towing application, environmental considerations, etc.)

- i** For normal use Moog recommends the CAN bus data cable "UNITRONIC® BUS LD" supplied by LAPP KABEL (<http://www.lapp.de>) or "577 FlexLife™ Thin Cable" or the "5710 FlexLife™ Mid Cable" or the "575 FlexLife™ Thick Cable" supplied by Hans Turck GmbH & Co. KG (<http://www.turck.com>).
- i** CAN bus interface cables are available from Moog as accessories, in a variety of lengths.
⇒ "11.6 Interface Cables" on page 120

7.6 E-Bus

Communication within E-bus groups is done over the E-bus.

E-Bus

Notes on establishing E-bus groups:

⇒ "7.7.2 E-Bus Groups" on page 65

Examples of E-bus groups:

⇒ "7.7.2.1 Examples" on page 66

7.6.1 E-Bus Interface

The E-bus interface is set up as a serial cyclic shift register. Every communication cycle reserves for each extension module four bytes each in the send and receive messages.

E-Bus Interface

The 40 pole Q-connectors are located laterally on the DIN rail modules that have an E-bus interface.

Q-Connector

When the modules are joined with no gaps and are locked on the DIN top-hat rail, the E-bus connection will be properly established over the Q-connectors.

Views of DIN rail modules:

⇒ "5.1.1 Views of the Module" on page 29

Mounting DIN rail modules:

⇒ "5.1.4.1 Mounting DIN Rail Modules" on page 33

E-bus interface of the MSC II:

⇒ "10.14 E-Bus Interface" on page 108

7.6.2 E-Bus Communication

Communication within E-bus groups takes place exclusively between the E-bus master and the E-bus slaves.

The master sends E-bus messages with output data to the slaves within its E-bus group and receives from the slaves E-bus messages with input data.

Direct communication between the slaves of an E-bus group over the E-bus is not possible.

E-Bus Communication

7.6.2.1 E-Bus Master and E-Bus Slaves

The following M3000® modules can be employed as E-bus master in an E-bus group:

- MSC I and MSC II
- RDIO

Permissible Masters	Permissible Slaves		Remarks
	Number	Modules	
MSC II	7	I/O extension modules, such as QAIO and QDIO (E-bus must be carried through on the Q-connector)	E-bus groups with MSC IIs as masters function as stand-alone groups. Configuration of the E-bus interface of the MSC II and the slaves: ⇒ "10.14.1 Configuration of the E-Bus Interface" on page 108
RDIO	6	QDIOs  Other M3000® modules must not be attached to an RDIO!	E-bus groups with RDIOs as master must be actuated over the CAN bus.

Permissible Masters and Slaves in E-Bus Groups

Table 12: Permissible Masters and Slaves in E-Bus Groups

The duration of transmission of E-bus messages is not influenced by the number of DIN rail modules in the E-bus group.

⇒ "7.6.3.3 Duration of Transmission of E-Bus Messages" on page 62

7.6.3 MSC II as E-Bus Master

7.6.3.1 Starting the E-Bus Communication

At program download from the MACS development environment, the E-bus configuration contained in the PLC configuration will be transferred to the MSC II. If slaves are set in the E-bus configuration, the MSC II checks whether the configured slaves are actually attached. Communication over the E-bus is possible only when the slaves actually attached correspond with the arrangement set in the PLC configuration. Otherwise, an error message will be displayed in the MACS development environment.

The E-bus communication will be started automatically after an application program is started. If communication over the E-bus is successful, the LED «EBus» will illuminate on the front panel of the MSC II.

⇒ "10.4.2 LEDs" on page 81

If an error occurs during the communication or if the digital output 'Outputs Enabled' of the MSC II is switched to the 0 state, the E-bus communication will be terminated and the LED «Ebus» will be turned off.

⇒ "10.17.2 'Outputs Enabled' Output (LED «OutEN»)" on page 111

Starting the E-Bus Communication

7.6.3.2 Update Rate of E-Bus Messages

WARNING



The I/O extension modules QDIO and QAIO monitor the E-bus activity and disable their outputs if they do not receive an E-bus message more frequently than 50 ms.

To avoid this, set the value of the system basetick or the value of 'UpdateRate' so that the product of the two values is less than 50 ms.

The update rate setting of the E-bus depends on the system basetick. The system basetick is the time base for the operating system tasks, used in the application program. Task time bases of tasks can be set to integer multiples of the system basetick.

The update rate is defined by setting the E-bus module parameter 'UpdateRate' in the PLC configuration of the MACS development environment. 'UpdateRate' can be set so that an E-bus message will always be sent at the end of this task's cycle (or after 2, 3, 5, 10, 15 or 20 cycles).

E-Bus Communication: Message Update Rate

MSC II Module Parameter 'Basetick'	E-Bus Module Parameter 'UpdateRate'	Update Rate of E-Bus Messages
1 ms	'every third cycle'	An E-bus message is started cyclically every 3 ms (1 ms * 3).
3 ms	'every twentieth cycle'	An E-bus message would be started cyclically every 60 ms (3 ms * 20). However, since no E-bus message is sent more frequently than 50 ms, the I/O extension modules will disable their outputs. The outputs will be re-enabled with the next E-bus message.

Table 13: Update Rate of E-Bus Messages

7.6.3.3 Duration of Transmission of E-Bus Messages

The duration of transmission of the E-bus message, i.e., the length of time required to transmit the E-bus message, is determined by the E-bus clock frequency. The E-bus clock frequency is defined by setting the E-bus module parameter 'Frequency' in the PLC configuration of the MACS development environment.

- Clock frequency = 10 MHz → Duration of transmission = 42 µs
- Clock frequency = 5 MHz → Duration of transmission = 84 µs

The selected E-bus clock frequency does not influence the time required to execute the tasks.

- ⓘ When the E-bus group contains QAIOs 16/4, the clock frequency must be set to 5 MHz!
- ⓘ When the E-bus group contains QAIOs 2/2, the clock frequency must be set to 10 MHz!
- ⓘ The duration of transmission of E-bus messages is not influenced by the number of DIN rail modules in the E-bus group.

E-Bus Communication: Duration of Message Transmission

7.6.3.4 Scope of E-Bus Messages

The scope of the E-bus message depends on the slave types attached to the master.

E-Bus Communication: Scope of Messages

Communication with digital I/O extension modules (such as QDIO)

All input and output data of every digital I/O extension module is transmitted during every E-bus cycle.

Communication with analog I/O extension modules QAIO 16/4

The data for one output and one input from each analog I/O extension module will be transmitted during every E-bus cycle. Only the input and output data that is used in the application program will be transmitted.

Communication with analog I/O extension modules QAIO 2/2

All input and output data of every analog I/O extension module is transmitted during every E-bus cycle.

7.6.3.5 Example

One analog and one digital I/O extension module is connected to an MSC II.

E-Bus Communication: Example

 The E-bus interface of the MSC II and the inputs and outputs of the I/O extension modules are configured in the PLC configuration of the MACS development environment.

⇒ ["10.14.1 Configuration of the E-Bus Interface" on page 108](#)

The following inputs and outputs are used in the application program.

- QAIO 16/4: 7 analog inputs QAIO-IN1 to QAIO-IN7
3 analog outputs QAIO-OUT1 to QAIO-OUT3
- QDIO: 3 digital inputs QDIO-IN5 to QDIO-IN7
3 digital outputs QDIO-I/O13 to QDIO-I/O15

The basetick is set to 1 ms. The module parameter 'UpdateRate' is set to 'each cycle'.

Accordingly, the E-bus message starts cyclically every millisecond.

⇒ ["7.6.3.2 Update Rate of E-Bus Messages" on page 62](#)

The digital inputs and outputs of the QDIO are updated in every E-bus cycle; once every millisecond in this example.

However, only one analog input and one analog output of the QAIO 16/4 will be updated with each E-bus cycle. For this reason, each analog input is updated only every 7 ms and every analog output is updated only every 3 ms in this example.

Time	Cycle No./ Message No.	Update			
		Outputs		Inputs	
		QDIO	QAIO 16/4	QDIO	QAIO 16/4
1 ms	1	all	OUT1	all	IN1
2 ms	2	all	OUT2	all	IN2
3 ms	3	all	OUT3	all	IN3
4 ms	4	all	OUT1	all	IN4
5 ms	5	all	OUT2	all	IN5
6 ms	6	all	OUT3	all	IN6
7 ms	7	all	OUT1	all	IN7
8 ms	8	all	OUT2	all	IN1
9 ms	9	all	OUT3	all	IN2
...

Table 14: Update Order for Inputs and Outputs of QDIO and QAIO 16/4

7.7 Networking DIN Rail Modules

When networking DIN rail modules, a distinction is made between the following control groups:

- E-Bus Groups
⇒ "7.7.2 E-Bus Groups" on page 65
- LocalCAN Bus Groups
⇒ "7.7.3 LocalCAN Bus Groups" on page 66
- WideCAN Bus Groups
⇒ "7.7.4 WideCAN Bus Groups" on page 67

Networking DIN Rail Modules

7.7.1 CAN and E-Bus Interfaces

- i** The M3000® modules mentioned here represent only a part of Moog's current product range. In addition to other M3000® modules, Moog's product range includes a large variety of accessories.
⇒ "11 Product Range" on page 114

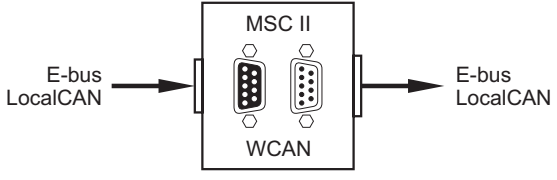
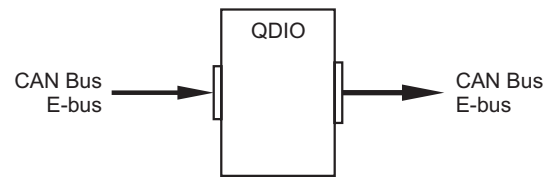
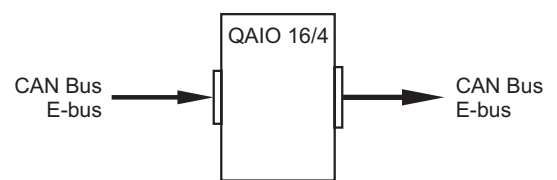
DIN Rail Module	Number of Connectors and Controllers
<p>MSC II</p>  <p>The diagram shows a rectangular module labeled 'MSC II'. On the left side, there are two input ports labeled 'E-bus' and 'LocalCAN'. On the right side, there are two output ports labeled 'E-bus' and 'LocalCAN'. Inside the module, there are two Q-connectors labeled 'MSC II' and 'WCAN'.</p>	<p>LocalCAN bus: 2 Q-connectors (lateral)</p> <p>WideCAN bus: 2 D-sub front panel connectors</p> <p>CAN bus controller: 2</p> <p>E-bus: 2 Q-connectors (lateral)</p>
<p>QDIO</p>  <p>The diagram shows a rectangular module labeled 'QDIO'. On the left side, there are two input ports labeled 'CAN Bus' and 'E-bus'. On the right side, there are two output ports labeled 'CAN Bus' and 'E-bus'.</p>	<p>CAN bus: 2 Q-connectors (lateral)</p> <p>CAN bus controller: 0</p> <p>E-bus: 2 Q-connectors (lateral)</p>
<p>QAIO 16/4</p>  <p>The diagram shows a rectangular module labeled 'QAIO 16/4'. On the left side, there are two input ports labeled 'CAN Bus' and 'E-bus'. On the right side, there are two output ports labeled 'CAN Bus' and 'E-bus'.</p>	<p>CAN bus: 2 Q-connectors (lateral)</p> <p>CAN bus controller: 0</p> <p>E-bus: 2 Q-connectors (lateral)</p>

DIN Rail Modules with CAN and E-Bus Interfaces

Table 15: DIN Rail Modules with CAN and E-Bus Interfaces (Section 1 of 2)

DIN Rail Module	Number of Connectors and Controllers
<p>RDIO</p> 	<p>CAN bus: 2 D-sub front panel connectors</p> <p>CAN bus controller: 1</p> <p>E-bus: 1 Q-connector (right)</p>
<p>QEBUS-CAN</p> 	<p>CAN bus: 2 Q-connectors (lateral) 2 D-sub connector (front)</p> <p>CAN bus controller: 0</p>

Table 15: DIN Rail Modules with CAN and E-Bus Interfaces (Section 2 of 2)

7.7.2 E-Bus Groups

E-bus groups are formed by joining DIN rail modules together at the Q-connectors. The modules within E-bus groups communicate over the internal E-bus.

⇒ "7.6 E-Bus" on page 60

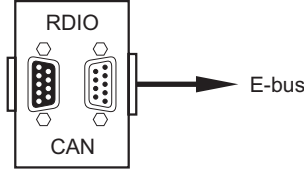
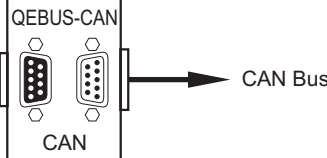
Observe the following when establishing E-bus groups:

- An E-bus group can have only one master to which the slaves attach.
⇒ Table 12 on page 61
- The module located farthest to the left of an E-bus group must be the master.
- The number of slaves that may be attached to a master is limited.
⇒ Table 12 on page 61
- QEBUS-CANs can be attached only at the far right or far left. QEBUS-CANs are not slaves and may therefore be attached additionally at the left or right regardless of the number of slaves.
- Only the master can communicate with the slaves. Direct communication between the slaves of an E-bus group over the E-bus is not possible.
⇒ "7.6.2 E-Bus Communication" on page 61
- Slaves must be attached to the master in direct succession. Modules that do not belong to this E-bus group must not be connected to this E-bus group by the Q-connector.
- RDIOs are not permissible slaves in E-bus groups and therefore must not be attached to the right of an MSC II, Q-module, or R-module.
- QAIO 16/4 and QAIO 2/2 can not be used on one E-bus group.
- QAIO 2/2 must be connected directly to the E-bus master or another QAIO 2/2 module.
- Information about arranging DIN rail modules:
⇒ "5.1.3 Arrangement on DIN Top-Hat Rails" on page 31

E-Bus Groups

7.7.2.1 Examples

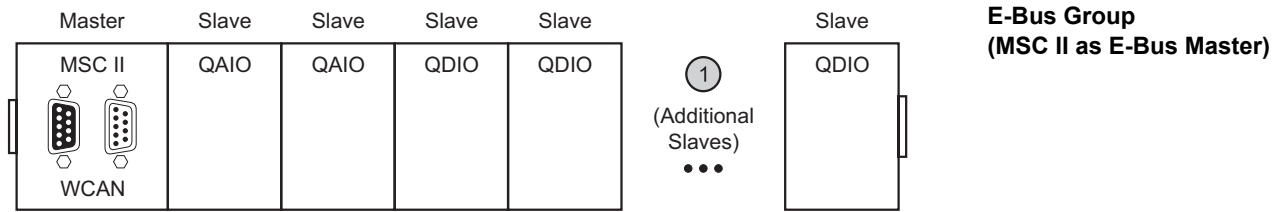

Figure 46: E-Bus Group (MSC II as E-Bus Master)

- ① Number of slaves that may be attached to the MSC II:
⇒ [Table 12 on page 61](#)

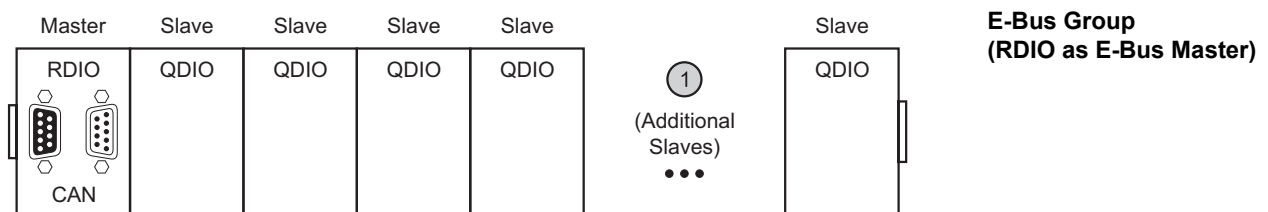

Figure 47: E-Bus Group (RDIO as E-Bus Master)

- ① Number of slaves that may be attached to the RDIO:
⇒ [Table 12 on page 61](#)

7.7.3 LocalCAN Bus Groups

LocalCAN bus groups are formed by joining MSC IIs together at the Q-connectors. The modules within LocalCAN bus groups communicate over the internal LocalCAN bus.

LocalCAN Bus Groups

Observe the following when establishing LocalCAN bus groups:

- The number of modules in a LocalCAN bus group is limited to 64 because CAN bus networks can only include a maximum of 64 network stations.
⇒ ["7.5.5.3 Number of Network Stations" on page 58](#)
- The switchable CAN bus termination resistor of the MSC II can be used as a termination resistor for the LocalCAN bus group.
⇒ ["10.15.1 CAN Bus Termination Resistor" on page 110](#)
- If a QEBUS-CAN is attached to the right, then the LocalCAN bus can be made available (using the QEBUS-CAN) for other CAN bus network stations that do not belong to the LocalCAN bus group.
- Information about arranging DIN rail modules:
⇒ ["5.1.3 Arrangement on DIN Top-Hat Rails" on page 31](#)

7.7.3.1 Example

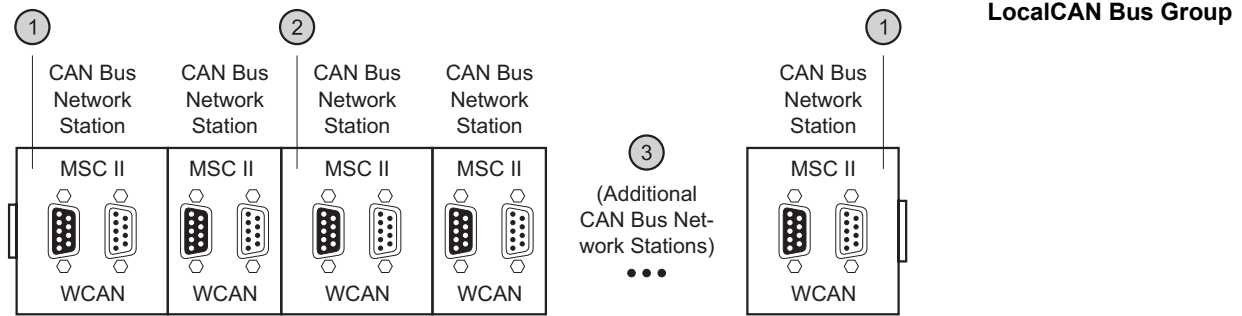

Figure 48: LocalCAN Bus Group (MSC IIs as CAN Bus Network Stations)

- ① The internal CAN bus termination resistor is switched on for MSC IIs that are used as the first or last CAN bus network station of a LocalCAN bus group.
⇒ ["10.15.1 CAN Bus Termination Resistor" on page 110](#)
- ② The internal CAN bus termination resistor is not switched on for MSC IIs that are located between the first and final CAN bus network stations of a LocalCAN bus group.
- ③ CAN bus networks with M3000® modules can include a maximum of 64 CAN bus network stations.
⇒ ["7.5.5.3 Number of Network Stations" on page 58](#)

7.7.4 WideCAN Bus Groups

WideCAN bus groups are formed by connecting the WideCAN terminal of the MSC II to additional CAN bus network stations. CAN bus network stations use the internal WideCAN bus to communicate within WideCAN bus groups.

WideCAN Bus Groups

Observe the following when establishing WideCAN bus groups:

- The switchable CAN bus termination resistor of the MSC II cannot be used as a termination resistor for the WideCAN bus group. Separate pluggable CAN termination resistors must be used for this.
⇒ ["10.15.1 CAN Bus Termination Resistor" on page 110](#)
- Notes on project planning for CAN bus networks:
⇒ ["7.5.5 CAN Bus Networks" on page 57](#)

7.7.4.1 Example

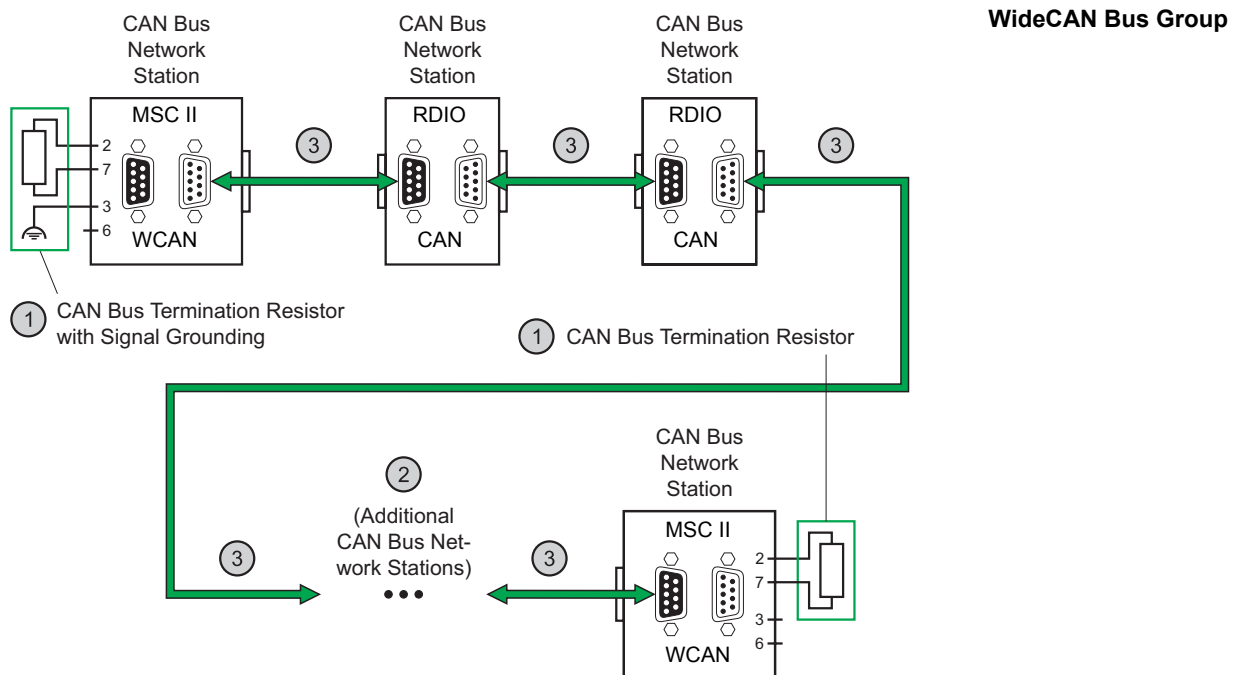

Figure 49: WideCAN Bus Group (MSC IIs and R-Modules as CAN Bus Network Stations)

- ① D-sub connectors with CAN bus termination resistors are available from Moog.
⇒ "11.7 CAN Bus Accessories" on page 120
- ② CAN bus networks with M3000® modules can include a maximum of 64 CAN bus network stations.
⇒ "7.5.5.3 Number of Network Stations" on page 58
- ③ CAN bus interface cable
⇒ "7.5.6 CAN Bus Interface Cable" on page 59

8 Shutdown and Service

WARNING



To avoid damage to M3000[®] modules or accessories, cleaning, maintenance, and repair tasks may be performed only by Moog or Moog's authorized service agents.

Warranty and liability claims for personal and material damage are excluded when, among other reasons, they are due to unauthorized repairs or other unauthorized interventions.

⇒ "1.4 Warranty and Liability" on page 3

Shutdown and Service:
Safety Instructions

WARNING



No work of any kind, such as mounting, removing, wiring, or repairs to the M3000[®] automation system or M3000[®] modules may be performed while the automation system or the modules are in operation!

There is a danger of:

- Uncontrolled movements
- Permanent damage
- Malfunctions

Before performing any work on the M3000[®] automation system or M3000[®] modules, it is essential that the system is stopped and the power supply is disconnected.

Therefore, all power supplies must be switched off, including those from attached peripherals such as externally supplied transmitters, programming devices, etc.!

WARNING



The M3000[®] automation system and M3000[®] modules must not come into direct contact with liquids, except where explicitly specified. Danger of short-circuit!

If they do come into direct contact with a liquid, immediately disconnect the power supply! Before bringing the system back into operation, it is essential that all affected components are completely dry and have been inspected by a suitably qualified technician.

8.1 Shutdown

WARNING



If an M3000[®] module is to be taken out of operation, the entire system must always be shut down and disconnected from all power supplies.

Therefore, all power supplies must be switched off, including those from attached peripherals such as externally supplied transmitters, programming devices, etc.!

The M3000[®] module must be protected against unintentional restarting!

If the M3000[®] module is connected to other devices and/or facilities, always consider the full consequences and take appropriate precautions before switching off the module.

Shutdown:
Safety Instructions

8.2 Service

WARNING



To avoid damage to M3000® modules or accessories, cleaning, maintenance, and repair tasks may be performed only by Moog or Moog's authorized service agents.

Warranty and liability claims for personal and material damage are excluded when, among other reasons, they are due to unauthorized repairs or other unauthorized interventions.

⇒ "1.4 Warranty and Liability" on page 3

CAUTION



To avoid damage to the internal components, never attempt to open M3000® modules!

Maintenance/Repair:
Safety Instructions

8.2.1 Maintenance/Service

M3000® modules are maintenance-free. They do not contain any components (such as batteries) that must be maintained or replaced.

Maintenance/Service

8.2.2 Repair

Only Moog and Moog's authorized service stations perform **Moog Authentic Repairs**. Only Moog and Moog's authorized service agents can access the required and most up-to-date specifications. These specifications make it possible to restore the M3000® modules' original performance and ensure the same high reliability and long service life of the M3000® modules after repairs are completed.



Repair



Figure 50: Repair Seal

Repair Seal

Moog's repair seal is the guarantee that a Moog Authentic Repair has been carried out.

-  If Moog receives a repair order for defective M3000® modules, Moog and Moog's authorized service agents reserve the right to repair the defective module or, alternatively, to replace the defective module with a module of identical or compatible specifications.
-  If Moog receives a repair order for defective M3000® modules, Moog and Moog's authorized service agents accept no liability for software and data installed by the customer. Like new modules, repaired modules or replacement modules are delivered only with a bootloader.

9 Transportation and Storage

WARNING



Maintain, under all circumstances, the required environmental conditions specified for transportation and storage of the M3000[®] automation system or M3000[®] modules.

⇒ "9.1 Environmental Conditions" on page 71

This ensures fault-free, reliable, and safe operation.

Transportation
and Storage:
Safety Instructions

CAUTION



To avoid condensation, do not start M3000[®] modules until they have reached ambient temperature.

CAUTION



To avoid damage, M3000[®] modules and accessories must be transported and stored in their original packaging.

Warranty and liability claims for personal or material damage will be excluded when they are the result of, among other things, storing or transporting M3000[®] modules or accessories outside of their original packaging.

⇒ "1.4 Warranty and Liability" on page 3

9.1 Environmental Conditions

Ambient temperature (IEC 61131-2)

–25 °C to +70 °C (–13 °F to +158 °F)

Relative air humidity (IEC 61131-2)

5 % to 95 % non-condensing

Contamination level (IEC 60664)

2

Resistance to corrosion (IEC 60068)

No protection

Air pressure (IEC 61131-2)

≥ 70 kPa (corresponds to an elevation of ≤ 3,000 m (3,280 yd))

Drop height (free fall in the original packaging) (IEC 60068-2-31)

≤ 1 m (39 in)

Transportation
and Storage:
Environmental Conditions

10 MSC II (Moog Servo Controller)

The MSC II is a programmable multi-axis controller that facilitates rapid and precise control of process variables such as position, speed, and power. It is suitable for use with both electric and hydraulic drives.

MSC II: Programmable Multi-Axis Controller

The MSC II is programmed and configured with the MACS development environment (complies with IEC 61131).

⇒ ["3.5 Application Programs" on page 25](#)

10.1 Performance Characteristics

10.1.1 Interfaces

The MSC II provides the following interfaces:

Interfaces of the MSC II

- 1 Serial interface
 - «SIO» connector for use as a free user interface⇒ ["10.16 Serial Interfaces" on page 111](#)
- 1 E-bus interface on both lateral Q-connectors (for establishing E-bus groups)
⇒ ["10.14 E-Bus Interface" on page 108](#)
- 2 CAN bus interfaces
 - WideCAN: 2 connectors «WCAN» (connected internally 1:1)
 - LocalCAN: 2 internally on both lateral Q-connectors⇒ ["10.15 CAN Bus Interfaces" on page 109](#)
- 1 Ethernet interface on the front panel
 - «LAN» front panel connector⇒ ["10.5.1.1 Ethernet Communication Interface" on page 84](#)
- 2 RT-ETH Real Time Ethernet interfaces (optional)
 - «RT-ETH1» and «RT-ETH2» front panel connectors
- 2 USB 1.1 Host interfaces with USB-A connector
 - «USB1» and «USB2» connector
- 1 Fieldbus interface
 - «F-Bus» connector
(provided for optional fieldbus extension, such as Profibus)
- 4 Digital sensor interfaces according to TIA/EIA 422/485 (previously RS 422/485) for position transducers or shaft encoders with SSI interface or incremental sensor signals
⇒ ["10.13 Digital Sensor Interfaces" on page 101](#)

10.1.2 I/Os (Inputs/Outputs)

The MSC II provides the following I/Os:

- 4 Digital I/Os
each individually configurable as an input or an output
⇒ "10.10 Digital I/Os" on page 93
- 1 Digital output 'Outputs Enabled'
⇒ "10.17.2 'Outputs Enabled' Output (LED «OutEN»)" on page 111

 The I/Os are configured in the PLC Configuration of the MACS development environment.

**I/Os (Inputs/Outputs)
of the MSC II**

10.1.3 Safety Functions

The MSC II provides the following safety functions:

- Watchdog for monitoring the functionality of the software
⇒ "10.17.1 Watchdog" on page 111
- Output 'Outputs Enabled' for signaling the activation of all outputs as well as EtherCAT communication
⇒ "10.17.2 'Outputs Enabled' Output (LED «OutEN»)" on page 111

**Safety Functions
of the MSC II**

10.2 General Specifications

Dimensions

Overall W × H × D in mm (in):
124 × 170 × 85.5 (4.88 × 6.69 × 3.37)
⇒ Figure 51 on page 74

Dimensions of the other DIN rail modules:
⇒ "5.1.2 Dimensions" on page 30

Weight

Approx. 1 kg (2.2 lb) without plug-in terminal strips, with license key

Processor

PowerPC CPU 400 MHz, 32 Bit, RISC architecture with floating point unit

Memory

32 MB flash EEPROM
128 MB RAM

Data retention

> 10 Years for all data that is saved in the flash EEPROM, i.e., boot project, error messages

**General Specifications
of the MSC II**

10.2.1 Dimensions

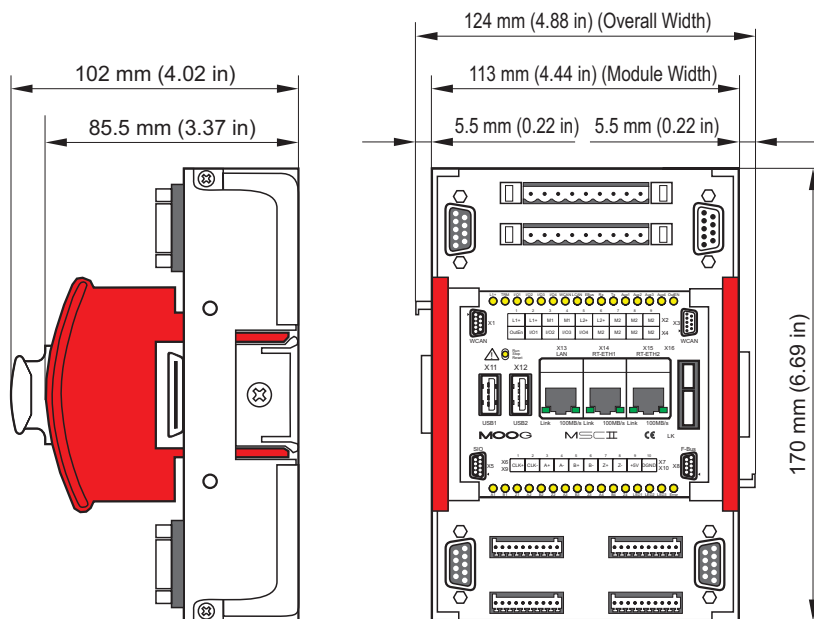

Figure 51: Dimensions of the MSC II

Dimensions of the MSC II

10.2.2 Environmental Conditions

WARNING



Maintain under all circumstances the required environmental conditions specified for the M3000[®] automation system or M3000[®] modules.

This ensures fault-free, reliable, and safe operation.

WARNING



It is not permissible to operate the M3000[®] automation system or M3000[®] modules in a potentially explosive environment.

WARNING



The M3000[®] automation system and M3000[®] modules must not come into direct contact with liquids, except where explicitly specified. **Danger of short-circuit!**

If they do come into direct contact with a liquid, immediately disconnect the power supply! Before bringing the system back into operation, it is essential that all affected components are completely dry and have been inspected by a suitably qualified technician.

Environmental
Conditions:
Safety Instructions

10.2.2.1 Climatic Conditions

Ambient temperature (IEC 61131-2)

For operation (when installed properly): +5 °C to +55 °C
(+41 °F to +131 °F)
Average temp. over 24 hours: max. +50 °C (+122 °F)
For transportation and storage
(in the original packaging): -25 °C to +70 °C
(-13 °F to +158 °F)

**Environmental
Conditions:
Climatic Conditions**

Relative air humidity (IEC 61131-2)

For operation: 10 % to 95 % non-condensing
For transportation and storage
(in the original packaging): 5 % to 95 % non-condensing

Contamination level (IEC 60664)

2

Resistance to corrosion (IEC 60068)

No protection

Operating Elevation (IEC 61131-2)

≤ 2,000 m (2,187 yd) above MSL

Air pressure for transportation (IEC 61131-2)

≥ 70 kPa (corresponds to an elevation of ≤ 3,000 m (3,280 yd))

10.2.2.2 Mechanical Conditions and Requirements

Sinusoidal oscillations (IEC 60068-2-6)

10 Hz ≤ f < 57 Hz: 0.0357 mm (0.0014 in) continuous amplitude
0.075 mm (0.00295 in) random amplitude
57 Hz ≤ f < 150 Hz: 0.5 g continuous constant acceleration
1.0 g random constant acceleration
f > 150 Hz: not defined

**Environmental
Conditions:
Mechanical Conditions
and Requirements**

Shock (IEC 60068-2-27)

Random peaks up to 15 g longer than 11 ms, half-sine wave in each of the three orthogonal axes

Drop height (free fall in the original packaging) (IEC 60068-2-31)

≤ 1 m (39 in)

Protection class (IEC 60529)

IP20

10.2.2.3 Electrical Conditions and Requirements

Power supply

24 V DC
(Safety Extra-Low Voltage (SELV) according to DIN EN 60950-1)
Specified voltage range: 18–36 V DC
⇒ "6.2 Power Supply" on page 39

**Environmental
Conditions:
Electrical Conditions
and Requirements**

Insulation resistance

Rated voltage: 0–50 V DC
Test voltage for 2,000 m (2,187 yd) operating elevation: 500 V DC

10.3 Block Diagram

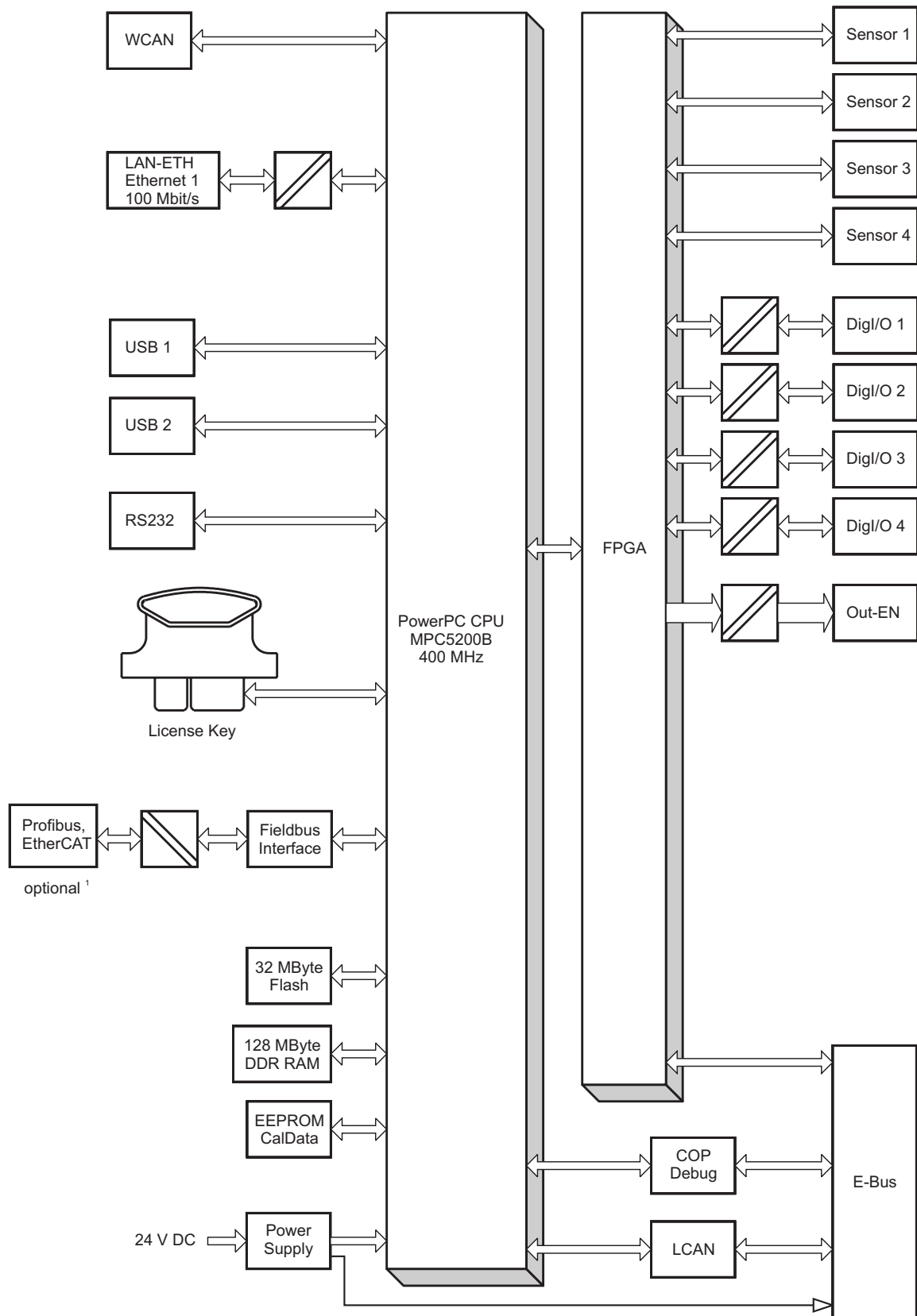

Figure 52: Block Diagram of the MSC II

¹⁾ Hardware option. When ordering the MSC II, the type of the fieldbus interface must be specified.

10.4 View of the Module and Terminal Assignment

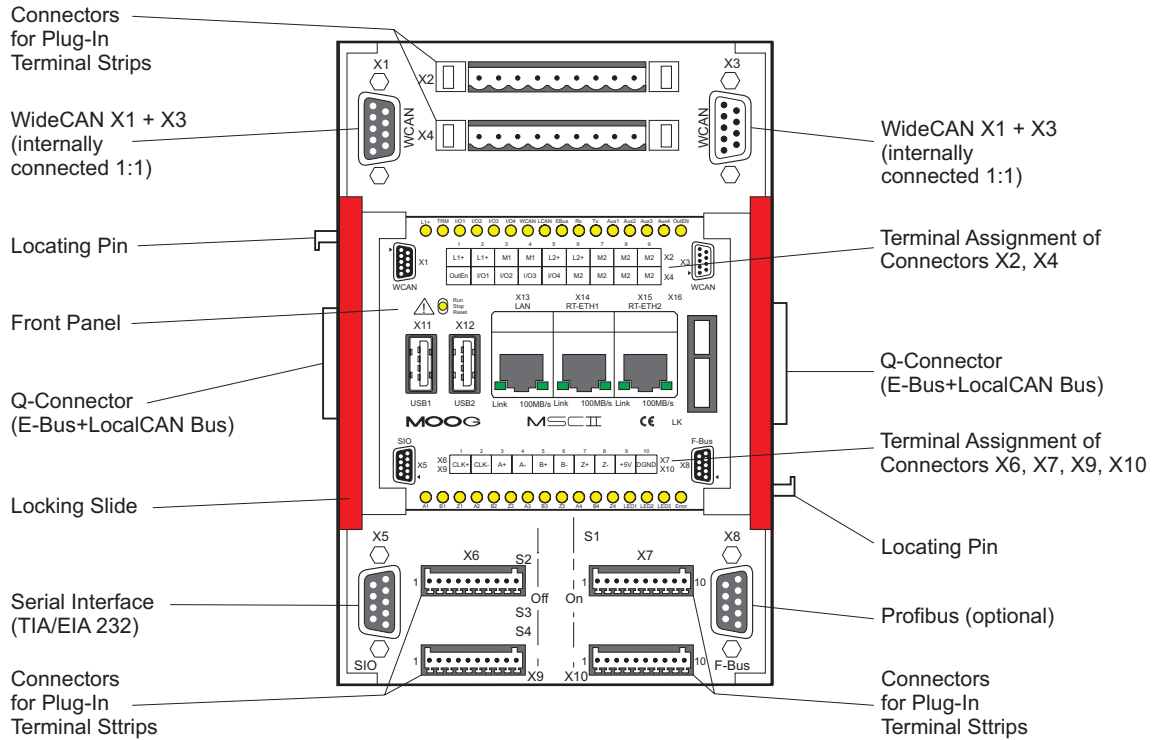

Figure 53: Front View of the MSC II

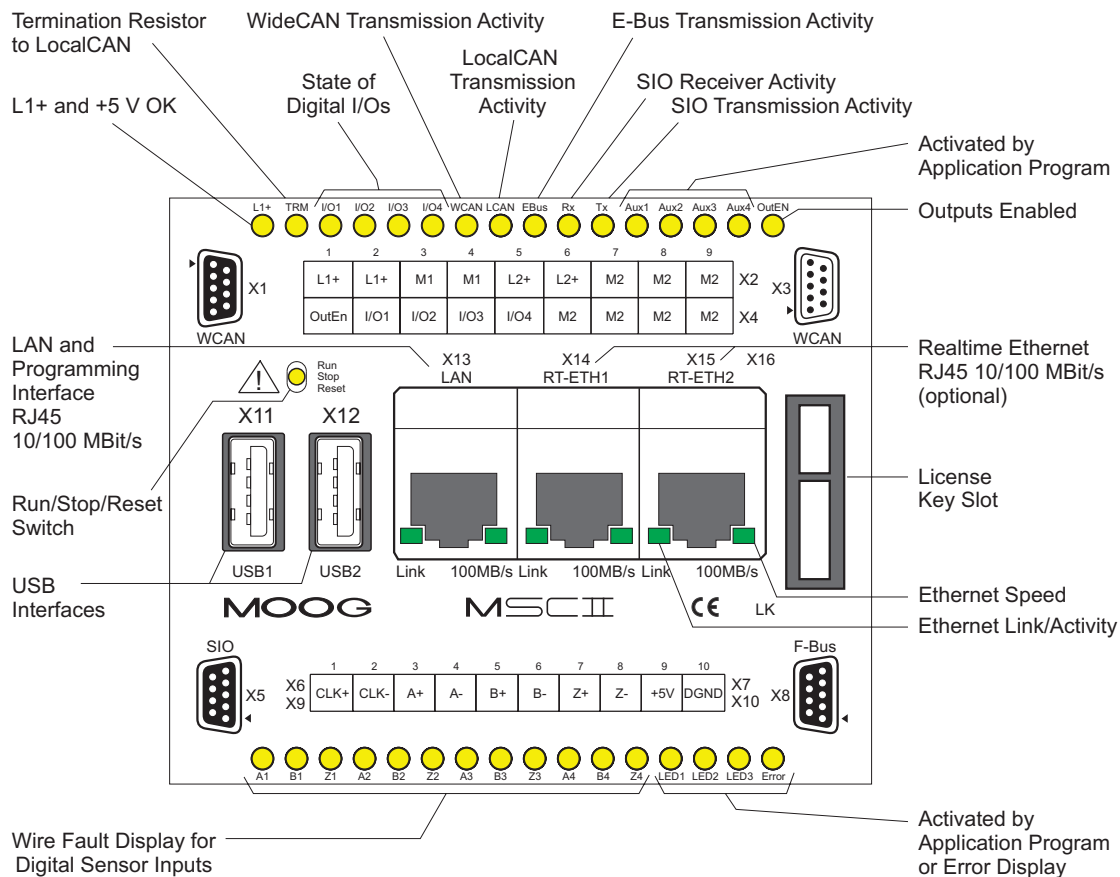

Figure 54: Front Panel of the MSC II

10.4.1 Terminal Assignment





Connector	No.	Assignment	Circuit	
 X1 WCAN	1			WCAN (WideCAN)
	2	CAN-L	CAN-	
	3	DGND	Ground for the CAN bus interface	
	4			
	5			
	6			
	7	CAN-H	CAN+	
	8			
	9			
 X2	1	L1+	Power supply for the MSC II's internal electronics (24 V DC SELV) ⇒ "6.2 Power Supply" on page 39	Power Supply
	2	L1+	Power supply for the MSC II's internal electronics (24 V DC SELV)	
	3	M1	Ground for the internal electronics' power supply	Digital I/Os
	4	M1	Ground for the internal electronics' power supply	
	5	L2+	Power supply for the MSC II's digital I/Os (24 V DC SELV) ⇒ "10.10.2 Power Supply" on page 93	
	6	L2+	Power supply for the MSC II's digital I/Os (24 V DC SELV)	
	7	M2	Ground for the digital I/Os' power supply	
	8	M2	Ground for the digital I/Os' power supply	
	9	M2	Ground for the digital I/Os' power supply	
 X3 WCAN	1			WCAN (WideCAN)
	2	CAN-L	CAN-	
	3	DGND	Ground for the CAN bus interface	
	4			
	5			
	6			
	7	CAN-H	CAN+	
	8			
	9			
 X4	1	OutEN	Digital output 'Outputs Enabled' ⇒ "10.17.2 'Outputs Enabled' Output (LED «OutEN»)" on page 111	Digital I/Os
	2	I/O1	Digital I/O 1 ⇒ "10.10 Digital I/Os" on page 93	
	3	I/O2	Digital I/O 2	
	4	I/O3	Digital I/O 3	
	5	I/O4	Digital I/O 4	
	6	M2	Ground for the digital I/Os' power supply	
	7	M2	Ground for the digital I/Os' power supply	
	8	M2	Ground for the digital I/Os' power supply	
	9	M2	Ground for the digital I/Os' power supply	

Table 16: Terminal Assignment of MSC II's Connectors (Section 1 of 4)





Connector	No.	Assignment	Circuit	
 X5 SIO TIA/EIA 232	1			SIO TIA/EIA 232
	2	Rx	TIA/EIA 232 receive data	
	3	Tx	TIA/EIA 232 send data	
	4			
	5	DGND	Ground for the TIA/EIA 232 interface	
	6			
	7			
	8			
	9			
 X6 Sensor 1	1	CLK1+	TIA/EIA 485 output, SSI sensor signal 1 clock+ ⇒ "10.13 Digital Sensor Interfaces" on page 101	Digital Sensor Interface 1
	2	CLK1-	TIA/EIA 485 output, SSI sensor signal 1 clock-	
	3	A1+	TIA/EIA 422 input, incremental sensor signal 1 A+ or SSI sensor signal 1 data+	
	4	A1-	TIA/EIA 422 input, incremental sensor signal 1 A- or SSI sensor signal 1 data-	
	5	B1+	TIA/EIA 422 input, incremental sensor signal 1 B+ or SSI sensor signal 1 slave clock+	
	6	B1-	TIA/EIA 422 input, incremental sensor signal 1 B- or SSI sensor signal 1 slave clock-	
	7	Z1+	TIA/EIA 422 input, incremental sensor signal 1 Z+	
	8	Z1-	TIA/EIA 422 input, incremental sensor signal 1 Z-	
	9	+5V	+5 V Power supply for sensor	
	10	DGND	Ground for the digital sensor interface	
 X7 Sensor 2	1	CLK2+	TIA/EIA 485 output, SSI sensor signal 2 clock+ ⇒ "10.13 Digital Sensor Interfaces" on page 101	Digital Sensor Interface 2
	2	CLK2-	TIA/EIA 485 output, SSI sensor signal 2 clock-	
	3	A2+	TIA/EIA 422 input, incremental sensor signal 2 A+ or SSI sensor signal 2 data+	
	4	A2-	TIA/EIA 422 input, incremental sensor signal 2 A- or SSI sensor signal 2 data-	
	5	B2+	TIA/EIA 422 input, incremental sensor signal 2 B+ or SSI sensor signal 2 slave clock+	
	6	B2-	TIA/EIA 422 input, incremental sensor signal 2 B- or SSI sensor signal 2 slave clock-	
	7	Z2+	TIA/EIA 422 input, incremental sensor signal 2 Z+	
	8	Z2-	TIA/EIA 422 input, incremental sensor signal 2 Z-	
	9	+5V	+5 V Power supply for sensor	
	10	DGND	Ground for the digital sensor interface	
 X8 F-Bus	1			Profibus (F-Bus)
	2			
	3	RxD/TxD-P	Receive / transmission data - positive potential	
	4	CNTR-P	Control signal for repeater (direction control)	
	5	DGND	Potential of transmission data (ground to 5 V)	
	6	VP	Power supply of the terminators (+5 V)	
	7			
	8	RxD/TxD-N	Receive / transmission data - negative potential	
	9	CNTR-N	Control signal for repeater (direction control)	

Table 16: Terminal Assignment of MSC II's Connectors (Section 2 of 4)





Connector	No.	Assignment	Circuit	
 Sensor 3	1	CLK3+	TIA/EIA 485 output, SSI sensor signal 3 clock+ ⇒ "10.13 Digital Sensor Interfaces" on page 101	Digital Sensor Interface 3
	2	CLK3-	TIA/EIA 485 output, SSI sensor signal 3 clock-	
	3	A3+	TIA/EIA 422 input, incremental sensor signal 3 A+ or SSI sensor signal 3 data+	
	4	A3-	TIA/EIA 422 input, incremental sensor signal 3 A- or SSI sensor signal 3 data-	
	5	B3+	TIA/EIA 422 input, incremental sensor signal 3 B+ or SSI sensor signal 3 slave clock+	
	6	B3-	TIA/EIA 422 input, incremental sensor signal 3 B- or SSI sensor signal 3 slave clock-	
	7	Z3+	TIA/EIA 422 input, incremental sensor signal 3 Z+	
	8	Z3-	TIA/EIA 422 input, incremental sensor signal 3 Z-	
	9	+5V	+5 V Power supply for sensor	
	10	DGND	Ground for the digital sensor interface	
 Sensor 4	1	CLK4+	TIA/EIA 485 output, SSI sensor signal 4 clock+ ⇒ "10.13 Digital Sensor Interfaces" on page 101	Digital Sensor Interface 4
	2	CLK4-	TIA/EIA 485 output, SSI sensor signal 4 clock-	
	3	A4+	TIA/EIA 422 input, incremental sensor signal 4 A+ or SSI sensor signal 4 data+	
	4	A4-	TIA/EIA 422 input, incremental sensor signal 4 A- or SSI sensor signal 4 data-	
	5	B4+	TIA/EIA 422 input, incremental sensor signal 4 B+ or SSI sensor signal 4 slave clock+	
	6	B4-	TIA/EIA 422 input, incremental sensor signal 4 B- or SSI sensor signal 4 slave clock-	
	7	Z4+	TIA/EIA 422 input, incremental sensor signal 4 Z+	
	8	Z4-	TIA/EIA 422 input, incremental sensor signal 4 Z-	
	9	+5V	+5 V Power supply for sensor	
	10	DGND	Ground for the digital sensor interface	
 USB 1	1	+5V	+5 V Power supply for slaves	USB 1
	2	D-	Data-	
	3	D+	Data+	
	4	DGND	Digital Ground	
 USB 2	1	+5V	+5 V Power supply for slaves	USB 2
	2	D-	Data-	
	3	D+	Data+	
	4	DGND	Digital Ground	
 LAN	1	Tx+	Transmit data+	Ethernet (LAN)
	2	Tx-	Transmit data-	
	3	Rx+	Receive data+	
	4			
	5			
	6	Rx-	Receive data-	
	7			
	8			

Table 16: Terminal Assignment of MSC II's Connectors (Section 3 of 4)

Connector	No.	Assignment	Circuit	
X14  RT-ETH1	1	Tx+	Transmit data+	Ethernet (RT-ETH1)
	2	Tx-	Transmit data-	
	3	Rx+	Receive data+	
	4			
	5			
	6	Rx-	Receive data-	
	7			
	8			
X15  RT-ETH2	1	Tx+	Transmit data+	Ethernet (RT-ETH2)
	2	Tx-	Transmit data-	
	3	Rx+	Receive data+	
	4			
	5			
	6	Rx-	Receive data-	
	7			
	8			

Table 16: Terminal Assignment of MSC II's Connectors (Section 4 of 4)

10.4.2 LEDs

Area	LED	Display	Explanation
Status	L1+	L1+/M1 and internal +5 V ok	Illuminates when the power supply for the MSC II's internal electronics is OK and the internal power pack is supplying +5 V. ⇒ "6.2 Power Supply" on page 39
	TRM	Termination resistor on LocalCAN	Illuminates when the termination resistor of the LocalCAN interface is switched on. ⇒ "10.15.1 CAN Bus Termination Resistor" on page 110
	I/O1	Internal status of the digital I/O 1	⇒ "10.10.1 Display of the Operational State" on page 93
	I/O2	Internal status of the digital I/O 2	
	I/O3	Internal status of the digital I/O 3	
	I/O4	Internal status of the digital I/O 4	
	WCAN	WideCAN transmission activity	Flashes in synchronization with the data that the MSC II is sending over the WideCAN interface. ⇒ "10.15 CAN Bus Interfaces" on page 109
	LCAN	LocalCAN transmission activity	Flashes in synchronization with the data that the MSC II is sending over the LocalCAN interface. ⇒ "10.15 CAN Bus Interfaces" on page 109
	EBus	E-bus transmission activity	Illuminates when the MSC II is sending data over the E-bus. ⇒ "7.6.3 MSC II as E-Bus Master" on page 61
	Rx	SIO receiver activity	Illuminates when the MSC II is receiving data over the SIO interface
Tx	SIO transmission activity	Illuminates when the MSC II is sending data over the SIO interfaces. ⇒ Table 18 on page 83	
User	Aux1	Activated by application program	Illuminates when the application program activates the LED.
	Aux2	Activated by application program	
	Aux3	Activated by application program	
	Aux4	Activated by application program	

Table 17: LEDs of the MSC II (Section 1 of 2)

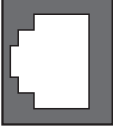
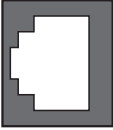
Area	LED	Display	Explanation
	OutEN	Outputs enabled	Illuminates when all outputs and the E-bus communication are under the control of the application program. ⇒ "10.17.2 'Outputs Enabled' Output (LED «OutEN»)" on page 111
Error	A1	Wire fault in the digital sensor input A1	Illuminates when no receiver is attached to the corresponding digital sensor interface or when there is a wire fault. ⇒ "10.13.2.1 Wire Fault Display LEDs" on page 102
	B1	Wire fault in the digital sensor input B1	
	Z1	Wire fault in the digital sensor input Z1	
	A2	Wire fault in the digital sensor input A2	
	B2	Wire fault in the digital sensor input B2	
	Z2	Wire fault in the digital sensor input Z2	
	A3	Wire fault in the digital sensor input A3	
	B3	Wire fault in the digital sensor input B3	
	Z3	Wire fault in the digital sensor input Z3	
	A4	Wire fault in the digital sensor input A4	
	B4	Wire fault in the digital sensor input B4	
	Z4	Wire fault in the digital sensor input Z4	
User	LED1	Activated by application program or error display	As long as LED «Error» does not illuminate, the application program can activate these LEDs (provided that the MSC II has successfully started and that the application program has started). The states that these LEDs will indicate while the application program is running are set in the application program. If «Error» illuminates or flashes in addition to these LEDs, this indicates MSC II's elementary operational states or errors. ⇒ Table 18 on page 83
	LED2	Activated by application program or error display	
	LED3	Activated by application program or error display	
	Error	Error display	
Ethernet	Link	Ethernet link/activity	Illuminates when the Ethernet link pulse is available and blinks at activity
	Speed	On = 100 Mbit/s	Ethernet connection speed

Table 17: LEDs of the MSC II (Section 2 of 2)

10.4.2.1 Display of Elementary Operational States and Errors

State	Explanation	User LEDs			
		LED1	LED2	LED3	Error
Ready	The MSC II was started successfully. The user LEDs «LED1», «LED2» and «LED3» are now available for the application program.	0	0	0	0
Booting	Boot process is running	1	0	0	0
Firmware update running	The update process of the firmware is running The firmware update process can take up to several minutes. The MSC II must not be switched off or reset during the update process. If it is switched off or reset during the update process, the firmware must be reloaded.	1	1	blinking	0
Firmware update finished	The update process of the firmware is finished	blinking	blinking	blinking	
Error	Error, no firmware loaded	1	0	0	1

1: LED illuminates
0: LED does not illuminate

Table 18: LEDs for Displaying Elementary Operational States and Errors after Switching on or Resetting the MSC II

10.5 Programming and Configuration

The MACS development environment is needed to create IEC 61131 application programs and configure the MSC II control module.

⇒ "3.5 Application Programs" on page 25

Programming and Configuration of the MSC II control module

10.5.1 Communication Between MSC II and MACS

WARNING



The MSC II control module's operational state can be altered with the MACS development environment when the MSC II control module is connected online with MACS.

This can be done by means of the following actions, for example:

- Stopping or resetting the program
- Setting breakpoints
- Activating the single step mode
- Downloading application programs
- Writing or forcing values

Therefore, the operator must always consider the effects and take appropriate precautions before altering the operational state of the MSC II control module with MACS.

The MSC II control module can use the following interface to communicate with the PC on which MACS is installed:

- **Ethernet interface**

with «LAN» front panel connector of the MSC II control module

⇒ "7.1 Ethernet" on page 47

⇒ "10.5.1.1 Ethernet Communication Interface" on page 84

i The Ethernet interface is configured in the PLC Configuration of the MACS development environment.

Refer to the documentation of the MACS development environment for detailed information about this.

Communication Between MSC II and MACS

10.5.1.1 Ethernet Communication Interface

Settings in the MACS development environment (communication parameters)

IP address at delivery = 192.168.1.2 (identical for all MSC II control modules without license key!)

Port = 1200

Target-Id = 0

Motorola Byteorder = Yes

i Each IP address may be used only once within a network. Therefore, when operating the MSC II control module within a network, the IP address should be changed only after consulting with the responsible system administrator.

IP address in the license key:

⇒ "10.6 License Key" on page 85

Interface cables

⇒ "7.1.3 Ethernet Interface Cables" on page 48

Communication Parameters of the Ethernet Interface

10.6 License Key

WARNING



The license key of the MSC II control module must be protected from electrostatic discharges!

Electrical discharges might damage the license key or delete the contents of the license key's memory.

WARNING



The license key may be inserted or removed only when the MSC II control module is powered down!

Attempting to insert or remove the license key during operation might damage the license key or the MSC II control module permanently.

WARNING



The license key must always remain inserted while the MSC II control module is in operation. Otherwise, the MSC II control module will not work.

If the license key is removed during operation, the application program will stop after a few minutes. If the MSC II control module is connected online to the MACS development environment, a corresponding error message will appear in MACS.

In addition, the digital output 'Outputs Enabled' will be switched to the 0 state, thereby disabling all of the MSC II control module's digital outputs and terminating fieldbus communication and E-bus communication.

⇒ "10.17.2 'Outputs Enabled' Output (LED «OutEN»)" on page 111

After switching off the MSC II control module and inserting the license key, the MSC II control module can be brought back into operation.

**License Key of the MSC II control module:
Safety Instructions**

10.6.1 Run-Time License and Accessible Libraries

The run-time license of the MSC II control module is saved in the license key.

The accessible MACS libraries also depend on the license key. If the application program attempts to access a MACS library that is not released by the license key used, the application program will not be able to start.



Detailed information about the MACS libraries accessible with the various license keys:

⇒ Table 29 on page 118

License Key of the MSC II control module: Run-Time License and Accessible Libraries

10.6.2 CANopen Node-ID and IP Address

The CANopen node-ID of the MSC II control module's CAN bus interfaces and the IP address of the MSC II control module's Ethernet interface are saved in the license key.

The CANopen node-ID and IP address can be set or modified in the following places:

- In the application program
- With the PLC Browser in the MACS development environment

The IP address is read from the license key only when the power supply is switched on or when the MSC II control module is reset.

The default license key settings are:

- IP address: 10.49.40.1
- CANopen node-ID: 127

License Key of the MSC II control module: CANopen Node-ID and IP Address

10.6.3 Mounting and Removing

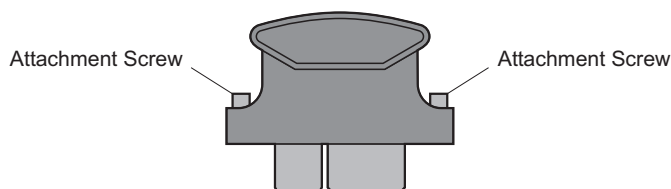

Figure 55: License Key of the MSC II control module with Attachment Screws

License Key of the MSC II control module with Attachment Screws

10.6.3.1 Required Tool

The following tool is required to mount and remove the license key:

- 3 mm screwdriver

License Key of the MSC II control module: Tool required for Mounting and Removing

10.6.3.2 Mounting the License Key

WARNING



The license key may be inserted or removed only when the MSC II control module is powered down!

Attempting to insert or remove the license key during operation might damage the license key or the MSC II control module permanently.

WARNING



If an M3000® module is to be taken out of operation, the entire system must always be shut down and disconnected from all power supplies.

Therefore, all power supplies must be switched off, including those from attached peripherals such as externally supplied transmitters, programming devices, etc.! The M3000® module must be protected against unintentional restarting!

If the M3000® module is connected to other devices and/or facilities, always consider the full consequences and take appropriate precautions before switching off the module.

CAUTION



When using a screwdriver, use caution to avoid slipping and causing personal injury or damage to the MSC II control module.

Mounting the License Key: Safety Instructions

Procedure for mounting the license key:

1. Switch off the MSC II control module power supply.
2. Insert the license key into the slot labeled «LK».
3. Fix the license key in place by carefully tightening the attachment screws.
 -  Incorrectly tightened attachment screws might cause license key errors.

Mounting the License Key**10.6.3.3 Removing the License Key****WARNING**

The license key may be inserted or removed only when the MSC II control module is powered down!

Attempting to insert or remove the license key during operation might damage the license key or the MSC II control module permanently.

Removing the License Key: Safety Instructions**WARNING**

If an M3000® module is to be taken out of operation, the entire system must always be shut down and disconnected from all power supplies.

Therefore, all power supplies must be switched off, including those from attached peripherals such as externally supplied transmitters, programming devices, etc.! The M3000® module must be protected against unintentional restarting!

If the M3000® module is connected to other devices and/or facilities, always consider the full consequences and take appropriate precautions before switching off the module.

CAUTION

When using a screwdriver, use caution to avoid slipping and causing personal injury or damage to the MSC II control module.

Procedure for removing the license key:

1. If it is running, stop the application program in the MACS development environment.
2. Switch off the power supply for the MSC II control module.
3. Loosen the license key's attachment screws.
4. Remove the license key from the slot labeled «LK».

Removing the License Key

10.7 Run/Stop/Reset Switch

The behavior of the Run/Stop/Reset switch controlling the Run state of the application program:

Run/Stop/Reset Switch of the MSC II

MACS ¹⁾	Run/Stop/Reset switch	Application program
Stop	Stop	Stop
Stop	Run	Stop
Run	Stop	Stop
Run	Run	Run

Table 19: Behavior of the Run/Stop/Reset Switch

¹⁾ Most recent state in the online mode (MACS logged on)

Regardless of the logging in to the MSC II with MACS, if the Run/Stop/Reset switch is at "Stop" position, the application program does not run. If the switch is in position "Run", then the execution state depends on the last state when MACS was logged in.

WARNING



If a boot project is stored at the MSC II and you perform a reset or power up, then take care that the application program run state is not only influenced by the last state of MACS, but also by the Run/Stop/Reset switch. If you switch from "Stop" to "Run", then a previously stopped application program may start operating again.

WARNING



Moving the Run/Stop/Reset switch into position "Stop" stops a running application program of the MSC II control module.

The application program will continue execution after switching back the Run/Stop/Reset switch to position "Run".

Moving the Run/Stop/Reset switch into position "Reset" will reset the MSC II. The processor will stop as soon as the Run/Stop/Reset switch is moved to position "Reset". No variables will be saved at that time.

When the Run/Stop/Reset switch is released from position "Reset", then the MSC II will behave as if the power supply has been switched on.

⇒ ["10.8.1.1 Switching on the Power Supply" on page 90](#)

In addition, the MSC II control module can be reset with the MACS development environment. Refer to the documentation of the MACS development environment for detailed information about this.

10.8 Power Supply

DANGER



The 24 V power supply terminals of all M3000[®] modules are protected against reverse polarity. If the polarity of these power supply terminals is reversed, the modules will not work.

Power Supply of the MSC II control module: Safety Instructions

WARNING



M3000[®] modules must be protected from overvoltages and/or reverse energization from the sensor to the module!

There is a danger of:

- Permanent damage by overheating or fire
- Malfunctions

M3000[®] modules must have the correct voltage, polarity, and terminal assignments.

Additional information about the power supply

⇒ "10.2.2.3 Electrical Conditions and Requirements" on page 75

⇒ "6.2 Power Supply" on page 39

10.8.1 Behavior at Switching on and Switching off

The following internal data resides in the flash EEPROM of the MSC II control module:

- Boot projects
- Error messages

There is no battery buffered memory area. The MSC II control module is maintenance-free.

Contents of the Flash EEPROM

WARNING



If the most recent status in the online mode (MACS logged in) was 'Run' before the MSC II control module was switched off or reset, the boot project will always be started after the MSC II control module is switched back on or reset.

This will occur regardless of which application program was previously running.

In other words, the application program that will be started automatically after the MSC II control module is switched on or reset might be different from the application program that was executing immediately prior.

Switching Back on or Resetting the MSC II: Safety Instructions

Application programs can be saved and executed in the MSC II in the following manner:

- As a boot project in the flash EEPROM
- In RAM

An application program saved as a boot project will be loaded into RAM whenever the MSC II's power supply is switched on or when the MSC II is reset.

- i** An application program that is only executed in RAM without being saved as a boot project will **not** be saved in the MSC II when it is switched off or when the power supply fails or the Run/Stop/Reset switch is moved to the Reset position.

After the power supply is switched back on or the Run/Stop/Reset switch is released from the Reset position, the application program must be downloaded again from the MACS development environment!

10.8.1.1 Switching on the Power Supply

WARNING



If the most recent status in the online mode (MACS logged in) was 'Run' before the MSC II control module was switched off or reset, the boot project will always be started after the MSC II control module is switched back on or reset.

This will occur regardless of which application program was previously running.

In other words, the application program that will be started automatically after the MSC II control module is switched on or reset might be different from the application program that was executing immediately prior.

After the power supply for the MSC II control module's internal electronics is switched on, the MSC II control module will perform the following actions:

1. The boot project (if one exists) is loaded into RAM.
2. The values of the RETAIN variables are loaded (assuming that variables of this type are used).
3. The boot project starts (if one exists and the most recent status in the on-line mode (MACS logged in) was 'Run').

After these actions are complete, the MSC II control module is ready to communicate with the MACS development environment.

Switching on the Power Supply:
Safety Instructions

MSC II control module's Behavior at Switching on the Power Supply

10.9 Basetick

10.9.1 Characteristics

The basetick is the global clock source of the MSC II control module. All timings such as task cycle times or hardware access are directly derived from the adjusted basetick value.

The basetick can be adjusted in steps of 1 μ s within the range of 100 microseconds up to 3 milliseconds. The cycle time of several application tasks must be a multiple of the adjusted basetick. The basetick value is also significantly involved in the timing of all hardware accesses.

Basetick cycle time can be adjusted within the PLC Configuration of the MACS development environment. The module parameter "Basetick" (index 2 of the root module) may be adjusted within the range of 100 to 3000. This value equals the basetick cycle time in μ s. The default value is 1000 = 1 ms.

Basetick

10.9.2 Timing Diagram

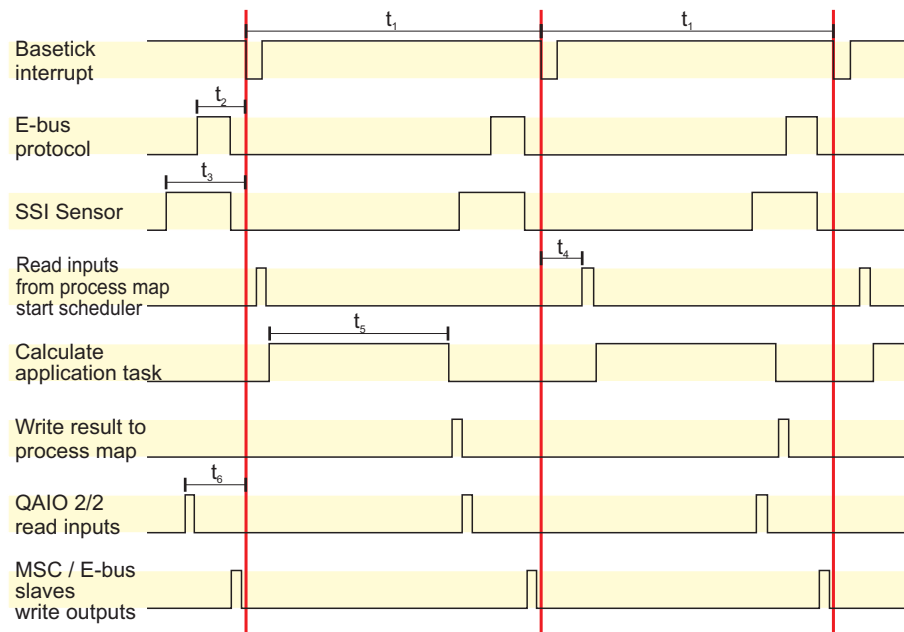

Timing diagram of the MSC II control module

Figure 56: Timing diagram of the MSC II control module

Desig.	Kind of time period	Value	Explanation
t_1	Basetick cycle time	100...3000 μ s	
t_2	E-bus start time	42 / 84 μ s	
t_3	SSI Sensor start time	410 μ s	Depending on application
t_4	Task reaction time	approx. 20 μ s	
t_5	Task calculation time	Max. 70 % task cycle time	Depending on application
t_6	QAI0 2/2 start sample inputs	45 μ s	

t_1 : Basetick cycle time

Basetick cycle time can be adjusted within MACS development environment. The module parameter "Basetick" (index 2 of the root module) may be adjusted within the range of 100 to 3000. This value equals the basetick cycle time in μ s.

Basetick cycle time

t_2 : E-bus start time

Start of E-bus communication cycle depends on E-bus frequency. When QAI0 16/4 modules are used within the E-bus group, E-bus frequency is shifted down to 5 MHz. Then a single E-bus communication cycle takes 84 μ s. By default 10 MHz E-bus frequency is used which halves the communication cycle.

E-bus start time

t_3 : SSI Sensor start time

Start of SSI sensor communication cycle depends on Sensor clock frequency and number of data bits. Sensor communication time must be smaller than basetick cycle time.

SSI Sensor start time

Maximum time calculation: 32 bit at 78 kHz \Rightarrow $1/78000 * 32 = 410 \mu$ s

- ⓘ SSI sensors need a recovery time of typically 10 μs to 20 μs . During this time no communication to with the sensor is possible. This should be considered when adjusting basetick and SSI sensor settings.

 t_4 : Task reaction time

Time until the system has free resources to react on the interrupt (interrupt latency).

Task reaction time

10.10 Digital I/Os

Each of the 4 digital terminals I/O1...I/O4 of the MSC II can be used as either an input **or** an output. Each digital output is internally connected back to a digital input.

This enables the application program to read the status of the digital outputs and compare it to the requested value.

- ❗ Whether a terminal will be used as an input **or** an output is set in the PLC Configuration of the MACS development environment.

The following digital output circuits are available:

- Open emitter outputs, switches to +24 V (L2+)

Basic wiring diagrams: ⇒ [figure 57 on page 95](#)

Digital I/Os I/O1...I/O4 of the MSC II control module

10.10.1 Display of the Operational State

The status LEDs «I/O1»...«I/O4» on the front panel of the MSC II control module show the internal operational state of the digital I/Os. These status LEDs are activated only when the application program is running.

If a terminal is configured to be an input, the associated LED will illuminate when it is internally detected that the input is in the 1 state and the input is used in the application program.

When a terminal is configured to be an output, the associated LED will illuminate if the output in the application program is in the 1 state.

As MSC II control modules have open emitter outputs, the LED will illuminate if the terminal is connected through to +24 V (L2+).

Basic wiring diagrams of the digital outputs: ⇒ [figure 57 on page 95](#)

- ❗ The status LEDs «I/O1»...«I/O4» will illuminate also if L2+ or M2 are not connected.
- ❗ The operational state of the digital I/Os can be queried with the aid of function blocks in the application program.

Status LEDs «I/O1»...«I/O4»

10.10.2 Power Supply

DANGER



The 24 V power supply terminals of all M3000® modules are protected against reverse polarity. If the polarity of these power supply terminals is reversed, the modules will not work.

WARNING



M3000® modules must be protected from overvoltages and/or reverse energization from the sensor to the module!

There is a danger of:

- Permanent damage by overheating or fire
- Malfunctions

M3000® modules must have the correct voltage, polarity, and terminal assignments.

Power Supply of the Digital I/Os of the MSC II control module: Safety Instructions

WARNING

The internal electronics of M3000® modules and attached sensors must be supplied with power from a permanently connected (unswitched) power supply that cannot be individually switched off, without switching off the module's power supply.

If a switched power supply is used, such as when there are intermediate switching devices (emergency stops, manual operators, etc.), the following problems might arise, depending on the state of the power supply for the internal electronics of the module and sensors (⇒ [table 3 on page 41](#)):

- Reverse energization from sensor to module
- Invalid sensor data

WARNING

Sensors that are connected to digital inputs of M3000® modules with several I/O groups, such as MSC I, QDIO, or RDIO, must under all conditions be supplied from the same power supply as the corresponding I/O group to which the sensor is connected!

Otherwise, if the power supply for the internal electronics of the module is switched off, there might be reverse energization from the sensor to the module.

There is a danger of:

- Uncontrolled movements
- Fault or failure of a manual control
- Permanent damage to the module
- Malfunctions

Digital I/Os of MSC II and MSD Motion Controller are protected against reverse energization.

The power supply for the digital I/Os of the MSC II control module is independent of the power supply for the MSC II control module's internal electronics (L1+/M1) and is established over the terminals L2+ and M2.

Power supply characteristics

⇒ ["6.2.1 Power Supply Characteristics" on page 39](#)

Connecting sensors to the power supply:

⇒ ["6.2.4 Connecting Sensors" on page 43](#)

Connecting the power supply for the internal electronics:

⇒ ["6.2.3 Connecting the Power Supply" on page 40](#)

10.10.3 Digital Outputs

The following digital output circuits are available:

- Open emitter outputs, switches to +24 V (L2+)

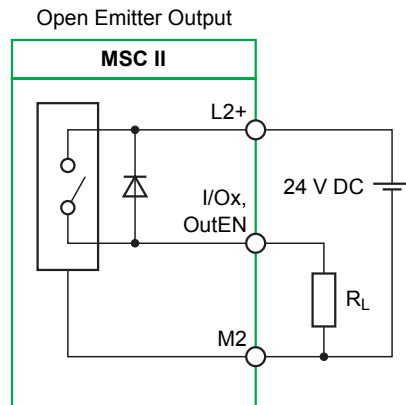

Figure 57: Basic Wiring Diagram of a Digital Open Emitter/Collector Output of the MSC II

- 1 Protective circuit with a limiting voltage of 50 V as protection against induced voltage spikes when there are inductive loads.
⇒ "10.10.3.2 Current Limiting and Overload Protection" on page 95

A digital **open emitter output** in the 1 state (conductive) connects the attached load R_L to the power supply terminal L2+.

- i The output 'Outputs Enabled' is always an open emitter output.
⇒ "10.17.2 'Outputs Enabled' Output (LED «OutEN»)" on page 111

10.10.3.1 Dependence on the 'Outputs Enabled' Signal

If the digital output 'Outputs Enabled' is in the 0 state (LED «OutEN» does not illuminate), all other outputs are disabled.

In this case, although the internal states of the digital outputs are shown on the front panel status LEDs «I/O1»...«I/O4» of the MSC II control module, they are not connected through to the output.

⇒ "10.17.2 'Outputs Enabled' Output (LED «OutEN»)" on page 111

10.10.3.2 Current Limiting and Overload Protection

All digital outputs are protected by an integrated power limiter and a thermal overload protection device.

In an overload condition, the affected output will be automatically disabled. After the output stage has been finished thermal cooling it returns to normal operation. If the overload is still connected, then the disable will happen again.

A protective circuit with a limiting voltage of 50 V with respect to +24 V (L2+) for open emitter outputs protects all outputs against induced voltage spikes when there are inductive loads.

Digital Outputs of the MSC II control module

Basic Wiring Diagram of a Digital Output of the MSC II control module

Open Emitter Output

Dependence of MSC II control module's Digital Outputs on the 'Outputs Enabled' Signal

Current Limiting and Overload Protection for Digital Outputs of the MSC II control module

10.10.3.3 Specifications

Number of digital outputs

Maximum 4

⇒ "10.10 Digital I/Os" on page 93

Type of outputs

Semiconductor, non-capacitive

Protective circuitry for inductive loads

Limiting voltage of 50 V (typ.) with respect to +24 V (L2+)

Power dissipation of protection devices when limiting

Max. 0.5 W per output

Max. 2 W per MSC II

Status display

One status LED per I/O

⇒ "10.10.1 Display of the Operational State" on page 93

Diagnosis function

The operational state of the digital I/Os can be queried with the aid of function blocks in the application program.

Power consumption for the internal control circuit (L2+/M2)

≤ 100 mA

Specifications of
MSC II control
module's Digital
Outputs

10.10.3.4 Load Connection

Total load (100 %)

2 A (4 x 0.5 A), when all 4 terminals are used as outputs

Overload protection

Electronic current limiting and thermal overload protection

Max. short-circuit current

< 8 A

Reverse energization protection

Digital outputs are protected against reverse energization

Output delay (hardware)

From 0 to 1: max. 100 µs

From 1 to 0: max. 100 µs

Update time

The update time corresponds to the task interval of the application program that actuates the output.

 The task interval (and thereby the update time of the outputs) is set in the task configuration of the MACS development environment.

Output capacitance

< 20 nF

Rated voltage

+24 V DC

Voltage loss (at rated current)

< 2 V

Rated current in 1 state

0.5 A

Leakage current in 0 state

Max. 0.1 mA

Load Connection of
MSC II control
module's Digital
Outputs

Parallel connection of outputs

Not permissible

10.10.3.5 Insulation Resistance**Insulation resistance**

Rated voltage: 0–50 V DC

Test voltage for 2,000 m (2,187 yd) operating elevation: 500 V DC

**Insulation Resistance of
MSC II control module's
Digital Outputs****10.10.4 Digital Inputs**

The digital inputs are current consuming inputs of the type 1 according to IEC 61131-2. They are designed for an input voltage rating of 24 V. The input values (0/1 state) are read cyclically. An open input is interpreted as the 0 state.

**Digital Inputs of the MSC II
control module****10.10.4.1 Basic Wiring Diagram****Basic Wiring Diagram of a
Digital Input of the MSC II
(Current Consuming)**

Figure 58: Basic Wiring Diagram of a Digital Input of the MSC II (Current Consuming)

10.10.4.2 Pulse Detection and Disturbance Suppression

The digital inputs are read cyclically. The sampling time corresponds to the task interval of the application program that reads the input.

**Pulse Detection and
Disturbance Suppression
of MSC II's Digital Inputs**

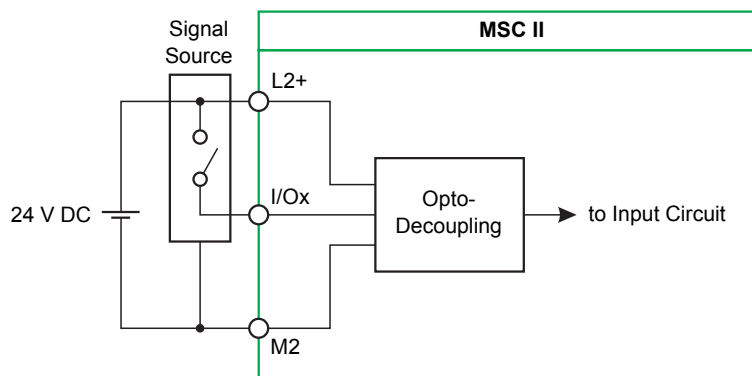
i The task interval (and thereby the sampling time of the inputs) is set in the task configuration of the MACS development environment.

For input pulses to be reliably detected, they must be longer than the task interval specified in the application program.

When defining the minimum pulse duration that can be detected by digital I/Os, the following differentiation is made:

- Pulses that are never detected; pulse duration: $\leq 50 \mu\text{s}$
- Pulses that can be detected (if the system reads the input when the pulse appears); pulse duration: $> 50 \mu\text{s}$
- Pulses that are always detected; pulse duration: $>$ the set task interval

The user may implement multiple sampling in the application program in order to suppress disturbance impulses. In doing so, the user must consider the tradeoff between the desired level of disturbance suppression and the required reaction time of the system.

10.10.4.3 Specifications

Number of the digital inputs

Maximum 4

⇒ "10.10 Digital I/Os" on page 93

Type

Type 1 according to IEC 61131-2, current consuming

Wire lengths

In the control cabinet: The voltage drop must be taken into consideration when choosing the wire cross section; there are no other practical limitations.

Field wiring: All relevant national regulations as well as the requirements of IEC 61131-3 must be fulfilled.

Load rated voltage L2+

24 V DC (safety extra-low voltage SELV according to DIN EN 60950-1)

Reverse polarity protection

Digital inputs are protected against reverse polarity

Potential isolation

Achieved with optocouplers

Status display

One status LED per I/O

⇒ "10.10.1 Display of the Operational State" on page 93

Alarms

Can be implemented in the application program

Input delay (hardware)

From 0 to 1: max. 100 µs

From 1 to 0: max. 100 µs

Sampling time

The sampling time corresponds to the task interval of the application program that reads the input.

⇒ "10.10.4.2 Pulse Detection and Disturbance Suppression" on page 97



The task interval (and thereby the sampling time of the inputs) is set in the task configuration of the MACS development environment.

Input capacitance

Max. 10 nF

Power consumption for the internal control circuit (L2+/M2)

≤ 100 mA

**Specifications of
MSC II control
module's Digital
Inputs**

10.10.4.4 U/I Working Ranges

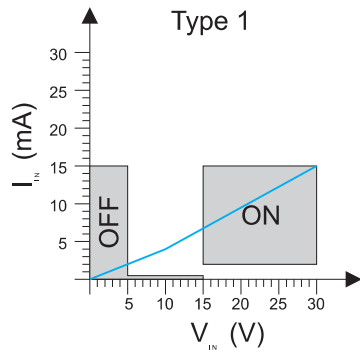

U/I Working Ranges of MSC II control module's Digital Inputs (Current Consuming)

Figure 59: U/I Working Ranges of MSC II control module's Digital Inputs (Current Consuming)

Input voltage (DC) of the external power supply L2+	rated voltage	$U_e = 24\text{ V}$
	upper limit	$U_{e\text{ max}} = 36\text{ V}$
	lower limit	$U_{e\text{ min}} = 18\text{ V}$
Limits for the 1 state	upper limit	$U_{H\text{ max}} = 30\text{ V}$ $I_{H\text{ max}} = 15\text{ mA}$
	lower limit	$U_{H\text{ min}} = 15\text{ V}$ $I_{H\text{ min}} = 2\text{ mA}$
Limits for the 0 state	upper limit	$U_{L\text{ max}} = 15/5\text{ V}$ $I_{L\text{ max}} = 0.5/15\text{ mA}$
	lower limit	$U_{L\text{ min}} = -3\text{ V}$ $I_{L\text{ min}} = \text{ND}$

Table 20: U/I Working Ranges of MSC II control module's Digital Inputs (Current Consuming)

10.10.4.5 Insulation Resistance

Insulation resistance

Rated voltage: 0–50 V DC

Test voltage for 2,000 m (2,187 yd) operating elevation: 500 V DC

Insulation Resistance of MSC II control module's Digital Inputs

10.11 Profibus DP Interface

The MSC II can optionally be equipped with a Profibus DP Slave interface.

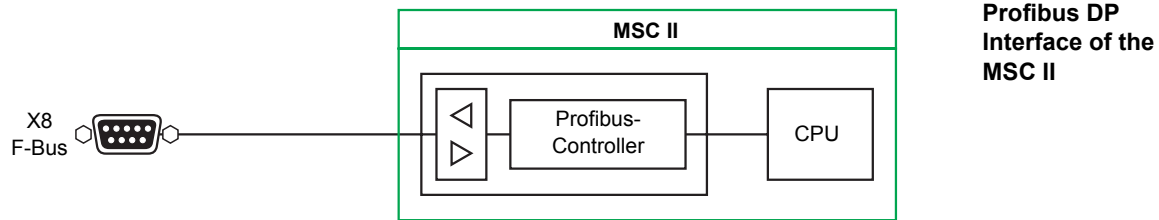

Figure 60: Profibus DP Interface of the MSC II

The configuration of the Profibus interface is defined in the application program.

Information about Profibus:

⇒ ["7.3 Profibus" on page 50](#)

Information about the Profibus interface cable:

⇒ ["7.3.4 Profibus Interface Cable" on page 52](#)

10.11.1 Profibus Termination

At the beginning and the end of any Profibus network, termination resistors must be connected to guarantee specified signal levels. These termination resistors are integrated in most common connectors.

10.11.2 Shielding

When connecting the stations, always use shielded cables to ensure high interference immunity of the system against electromagnetic emissions. The shield should be grounded on both sides where possible.

10.11.3 Profibus Slave Address

The slave station address of the Profibus interface of the MSC II can be set in the application program.

10.11.4 Profibus Baud Rate

The Profibus baud rate is defined by the Profibus master station. The MSC II Profibus slave interface is able to detect the baud rate and synchronize to it.

10.12 EtherCAT

MSC II is optionally available with dual EtherCAT interface.

The configuration of the network nodes is done in the PLC Configuration of the development environment MACS.

WARNING



Do not connect EtherCAT to any other Ethernet networks. The high rate of telegrams which are transmitted by EtherCAT will prevent other devices like computers and servers on the network from transmitting data.

There is a danger of

- Network overload/breakdown
- Malfunction of connected devices
- Data loss at connected devices

It is strongly recommended to use cables of a special color only for EtherCAT connections.

10.13 Digital Sensor Interfaces

The MSC II provides 4 digital sensor interfaces according to TIA/EIA 422/485 (previously RS 422/485) that can be used with devices such as position transducers or shaft encoders with an SSI interface or incremental sensor signals in different formats, such as pulse train or frequency modulation.

⇒ ["10.13.3 Connecting SSI Sensors" on page 102](#)

⇒ ["10.13.4 Connecting Incremental Sensors" on page 105](#)

 The sensor interfaces are configured in the PLC configuration of the MACS development environment.

Recommended cable types

- Use only shielded cables.
- The shield must be made of copper braiding with at least 80% coverage.
- The wire must be made of copper with a cross section of at least 0.25 mm² (23 AWG).
- In environments with a high amount of disturbance, use cables with twisted pair wires.

10.13.1 Termination Resistors

Each sensor interface of the MSC II is equipped with switchable termination resistors, one for each channel. The default state of the switches is ON. This means termination resistor is active for each differential pair. When using more sensor interfaces together with one sensor, the additional termination resistors need to be switched off (e.g. in SSI Slave mode).

Activation/deactivation of the resistors, are controlled by the DIP switches on the MSC II mainboard.

Digital Sensor Interfaces of the MSC II

Termination Resistors of MSC II's Digital Sensor Interfaces

10.13.2 Wire Fault Monitoring

The inputs A, B, and Z of the digital sensor interfaces of the MSC II are monitored for wire faults, regardless of which type of sensor is attached.

The signals supplied by the wire fault monitoring function are available in the application program. The user is responsible for evaluating these signals and defining the appropriate reaction to the appearance of a wire fault.

The status of wire fault monitoring is displayed by 12 front panel error LEDs of the MSC II. Each of the 12 TIA/EIA 422/485 inputs is assigned to one LED.
⇒ "10.13.2.1 Wire Fault Display LEDs" on page 102

10.13.2.1 Wire Fault Display LEDs

The 12 front panel error LEDs «A1», «B1», «Z1», «A2», «B2», «Z2», «A3», «B3», «Z3», «A4», «B4» and «Z4» of the MSC II will illuminate if:

- No sensor is attached to the corresponding sensor interface input
- There is a wire break

10.13.3 Connecting SSI Sensors

An SSI sensor supplies an absolute position signal or angle signal that can be read through the MSC II's sensor interface. The current value is available in the application program continuously.

If an SSI sensor is attached to the sensor interface of the MSC II, the MSC II can be used as a master or a slave. The sensor interface must then be inserted and configured as a master or slave, respectively, in the PLC configuration of the MACS development environment.

- ❗ If the MSC II is used as a master, the terminal assignment of the SSI interface will be different than if it is used as a slave!

MSC II connection diagram (master mode): ⇒ [figure 61 on page 103](#)

MSC II connection diagram (slave mode): ⇒ [figure 62 on page 104](#)

- ❗ If the MSC II interface is used as a SSI master, the «Bx» and «Zx» wire fault LEDs of the relevant interface will illuminate even if the sensor is connected and no wire fault is existent.
- ❗ If the MSC II interface is used as a SSI slave, the «Zx» wire fault LEDs of the relevant interface will illuminate even if the sensor is connected and no wire fault is existent.

**Wire Fault Monitoring
of MSC II's Digital
Sensor Interfaces**

**Wire Fault Display LEDs
of MSC II's Digital
Sensor interfaces**

**Connecting SSI Sensors
to the MSC II**

10.13.3.1 SSI Master Mode

In SSI master mode, the MSC II generates the SSI clock internally (sensor 1: CLK1, sensor 2: CLK2, sensor 3: CLK3, sensor 4: CLK4) with adjustable frequencies in the range between 78 kHz and 5 MHz. The frequencies are set in the PLC configuration of the MACS development environment.

The clock signal is generated synchronous to the adjusted basetick. MSC II calculates duration of a SSI data transmission depending on frequency and number of data bits. SSI communication is started exact that necessary time before each basetick.

i Make sure That the SSI communication time does not exceed the basetick period.

When idle, the clock signal will be in the 1 state. The first falling edge of the clock signal triggers the SSI sensor to hold its actual value. The clock signal's subsequent rising edge starts the data transmission of the SSI sensor. The output begins with the most significant bit (MSB). After a complete data set has been transmitted, the SSI sensor holds the data signal in the 0 state until the SSI sensor is ready for another transmission. The return of the data signal to the 1 state simultaneously fulfills the condition the SSI interface needs to trigger a new read-in cycle.

MSC II in SSI Master Mode

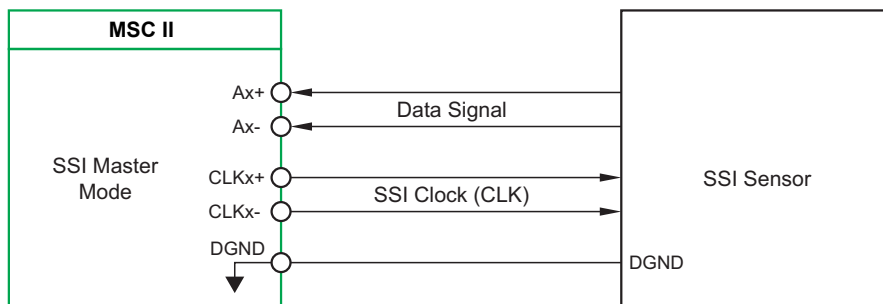

Connection Diagram of the MSC II in Master Mode

Figure 61: Connection Diagram of the MSC II in Master Mode

10.13.3.2 SSI Slave Mode

When in SSI slave mode, the MSC II does not generate its own SSI clock; instead, it reads the data in synchronization with an externally generated clock signal. The MSC II influences neither the SSI clock frequency nor the update rate with which new data is requested from the SSI sensor. In this mode, the MSC II reads the data signal with every falling edge of the clock.

With a symmetrical clock, the sensor interface can evaluate signals in the frequency range of 78 kHz to 5 MHz.

When the clock signal is asymmetrical, the width of the positive pulse must be smaller than 6.3 μs so that the sensor interface that is configured as an SSI slave will not perceive prematurely that the data transmission is concluded.

The clock signal must be in the 1 state for longer than 6.5 μs so that the sensor interface will save the value that has been read.

MSC II in SSI Slave Mode

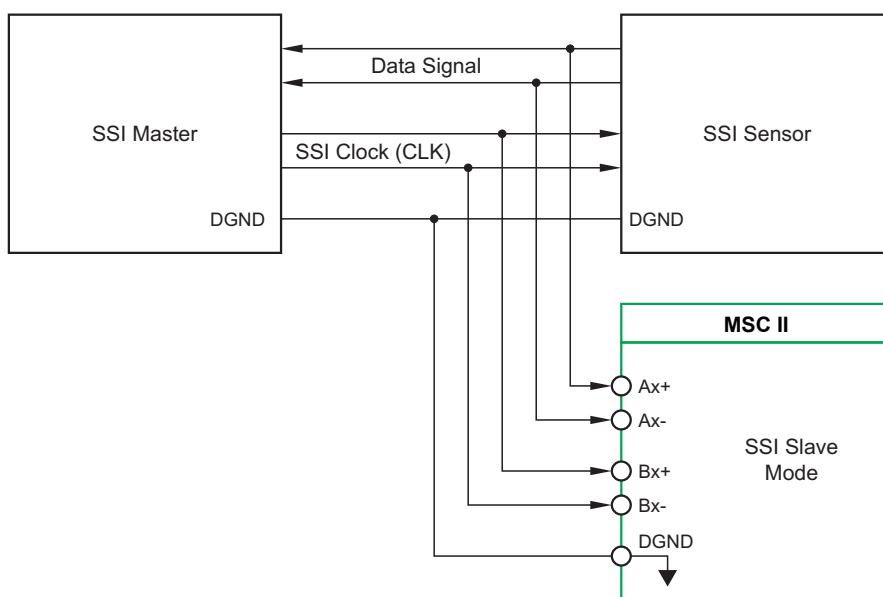

Connection Diagram of the MSC II in Slave Mode

Figure 62: Connection Diagram of the MSC II in Slave Mode

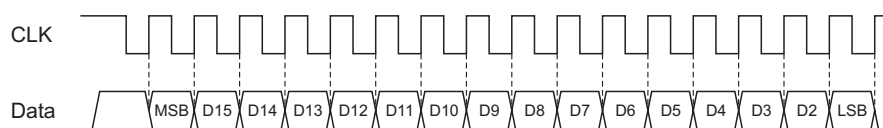

Signals Between the MSC II and a 16 Bit SSI Sensor (Example)

Figure 63: Signals Between the MSC II and a 16 Bit SSI Sensor (Example)

The signal levels comply with the standard TIA/EIA 422/485 (previously RS 422/485).

SSI sensors can be used that supply either gray code or binary coded data. The maximum possible resolution is 32 bits.

Coding of data and number of data bits can be adjusted in the PLC Configuration of the MACS development environment.

i The external SSI master must be capable of driving two TIA/EIA 422/485 inputs (including the termination resistors)!

10.13.4 Connecting Incremental Sensors

Incremental sensors supply a relative position or angle signal that the MSC II can read. In doing so, it can detect and evaluate impulse sequences with frequencies up to 8 MHz. Three different interfaces are supported by MSC II: Standard, Pulse Train and Frequency Modulation interfaces. The adaptation for the application program is done in the MACS development environment.

Connecting Incremental Sensors to the MSC II

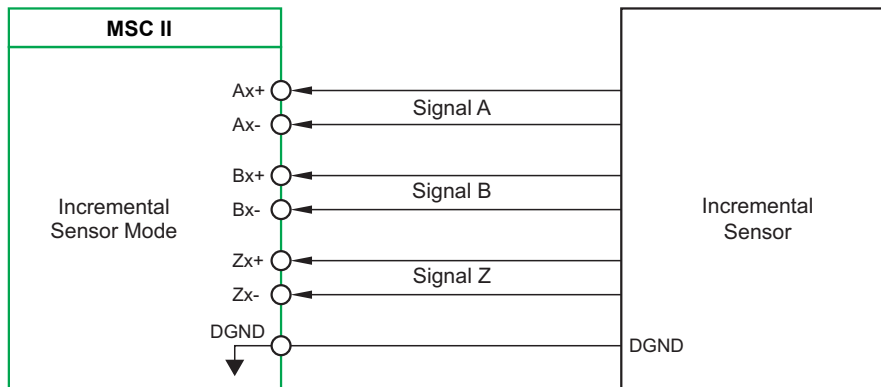

Connection Diagram of the MSC II with an Incremental Sensor

Figure 64: Connection Diagram of the MSC II with an Incremental Sensor

10.13.4.1 Incremental Encoder (Standard)

The adjustable 32 bit actual value in the MSC II is varied dependent on the leading or lagging sequence of A and B signals. Only 4 edges evaluation is used for this.

Example:

With 4 edges evaluation, a sensor with 1.024 dashes per revolution will supply to the application program 4.096 increments per revolution.

A check will be performed with every rising and falling edge of the A and B-signals to determine whether the B-signal is lagging behind the A-signal. If this is the case, the actual value will be increased by 1. If the A-signal lags behind the B-signal, the actual value will be decreased by 1.

The signal levels comply with the standard TIA/EIA 422/485 (previously RS 422/485).

The terminal designations will vary, depending on the manufacturer of the incremental sensor.

MSC II	Terminal Designation					
	A+	A-	B+	B-	Z+	Z-
Sensor supplied by Heidenhain	U_{a1}	$\overline{U_{a1}}$	U_{a2}	$\overline{U_{a2}}$	U_{a0}	$\overline{U_{a0}}$
Sensor supplied by Hengstler	a	\overline{a}	B	\overline{B}	N	\overline{N}
Sensor supplied by Stegmann	a	\overline{a}	B	\overline{B}	M	\overline{M}
Sensor supplied by Allen-Bradley	a	\overline{a}	B	\overline{B}	Z	\overline{Z}

Designations of Incremental Sensor Terminals

Table 21: Designations of Incremental Sensor Terminals (MSC II and Incremental Sensors from Various Manufacturers)

Figure 65 shows the signals to a standard incremental encoder interface. The given timings are valid for all operation modes.

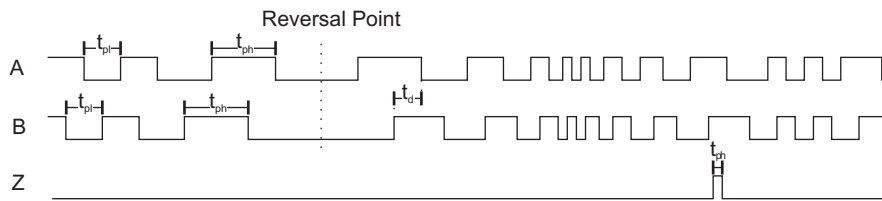

Figure 65: Timing requirements of incremental encoder signals

Timing requirements of incremental encoder signals

Time	Minimum	Description
t_{pl}	125 ns	Minimum pulse high time
t_{ph}	125 ns	Minimum pulse low time
t_d	1 ns	Edge to edge minimum delay time

Table 22: Timing of incremental encoders

The incremental encoder provides relative position information. The position value is incremented or decremented depending on the lead/lag relationship of the two signals (A and B) delivered by the incremental encoder. These signals may vary in frequency. The implemented interface can react on frequencies up to 8 MHz.

The position data is counted in a 32 bit free running counter. Each A/B signal edge triggers a 32 bit counter. This counter is overflowing to 0x0000 0000 or underflowing to 0xFFFF FFFF, depending on direction.

Each pulse on the Z input may reset the counter to zero. This function must be enabled by a MACS function block. By default the counter is free running and Z input is ignored.

On the left side of the dotted line B signal is leading. On the right side of the dotted line, the direction of the incremental encoder has changed. Now A is leading.

Following relations between counter update and lead/lag of signals is implemented:

- while line A leads, the counter is incremented with every rising and falling edge of line A and line B
- while line B leads, the counter is decremented with every rising and falling edge of line A and line B
- if Z input is enabled, the counter is always reset to zero when a pulse occurs on Z input

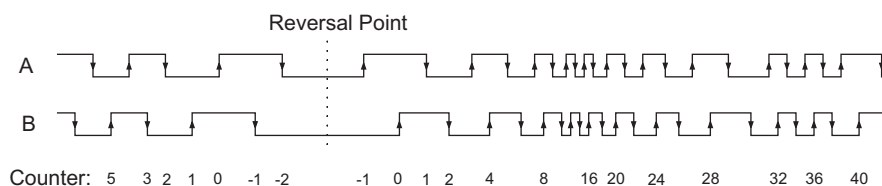

Figure 66: Timing of Standard Incremental Encoder

Timing of Standard Incremental Encoder

10.13.4.2 Incremental Encoder (Pulse Train positive logic)

- On the left side of the dotted line, while B signal is low, the counter becomes decremented.
- On the right side, while B signal is high, the direction has changed. Now the counter becomes incremented.

i Please make sure that any changes at B signal happen at least 100 ns before a rising edge at A signal.

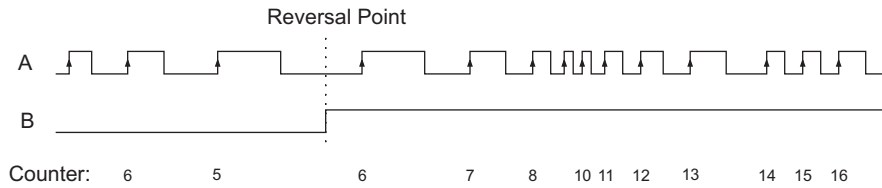

Figure 67: Timing of Pulse Train Incremental Encoder with positive logic

Timing of Pulse Train Incremental Encoder with positive logic

10.13.4.3 Incremental Encoder (Pulse Train negative logic)

- On the left side of the dotted line, while B signal is high, the counter becomes decremented.
- On the right side, while B signal is low, the direction has changed. Now the counter becomes incremented.

i Please make sure that any changes at B signal happen at least 100 ns before a rising edge at A signal.

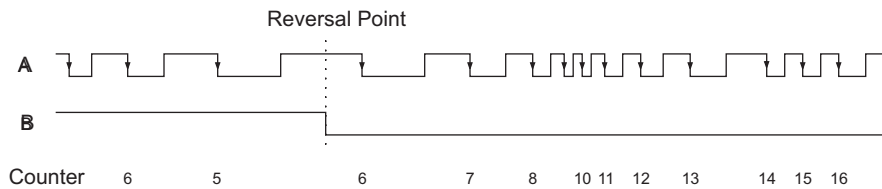

Figure 68: Timing of Pulse Train Incremental Encoder with negative logic

Timing of Pulse Train Incremental Encoder with negative logic

10.13.4.4 Incremental Encoder (Frequency Modulation positive logic)

- On the left side of the dotted line, while B signal is low, any rising edges of A signal decrements the counter state.
- On the right side, while A signal is low, the direction has changed. Now any rising edges of B signal increments the counter state.

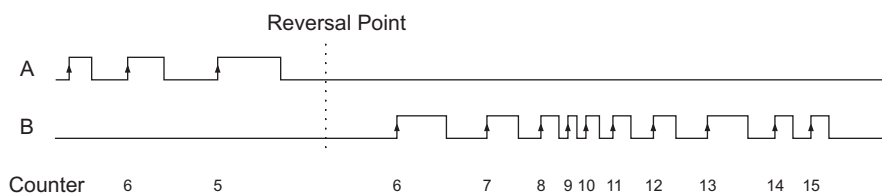

Figure 69: Timing of Frequency Modulation Incremental Encoder with positive logic

Timing of Frequency Modulation Incremental Encoder with positive logic

10.13.4.5 Incremental Encoder (Frequency Modulation negative logic)

- On the left side of the dotted line, while B signal is high, any falling edges of A signal decrements the counter state.
- On the right side, while A signal is high, the direction has changed. Now any falling edges of B signal increments the counter state.

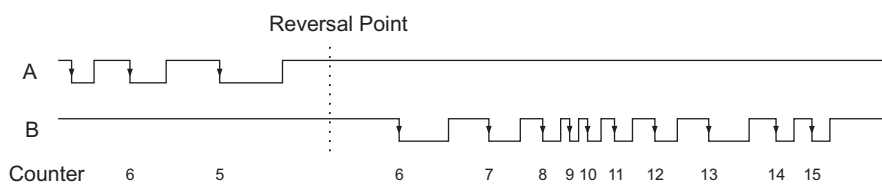

Figure 70: Timing of Frequency Modulation Incremental Encoder with negative logic

Timing of Frequency Modulation Incremental Encoder with negative logic

10.14 E-Bus Interface

The MSC II's inputs and outputs can be extended locally by establishing an E-bus group (by attaching up to 7 E-bus slaves to the E-bus interface).

E-Bus Interface of the MSC II

Examples:

- After 7 QDIO 16/16-0,5 extension modules are attached, an additional 112 digital inputs and 112 individually configurable digital I/Os will be available.
- After attaching 4 QAIO 16/4 extension modules and 3 QDIO 16/16-0,5 extension modules, an additional 64 analog inputs, 16 analog outputs, 48 digital inputs, and 48 individually configurable digital I/Os will be available.

Additional information about the E-bus interface and E-bus groups:

⇒ ["7.6.1 E-Bus Interface"](#) on page 60

⇒ ["7.6.2 E-Bus Communication"](#) on page 61

⇒ ["7.7.2 E-Bus Groups"](#) on page 65

10.14.1 Configuration of the E-Bus Interface

The E-bus interface of the MSC II is configured in the PLC configuration of the MACS development environment. The number and type of attached E-bus slaves must be specified in the configuration.

Configuration of the E-Bus Interface

The inputs and outputs of the attached E-bus slaves are also configured in the PLC configuration.

10.15 CAN Bus Interfaces

The MSC II is equipped with the following independent CAN bus interfaces that can be operated within CAN bus networks:

- **WideCAN** (2 «WCAN» front panel connectors of the MSC II)
- **LocalCAN** (2 internally on the lateral Q-connectors of the MSC II)

A separate CAN bus controller is included for every CAN bus interface.

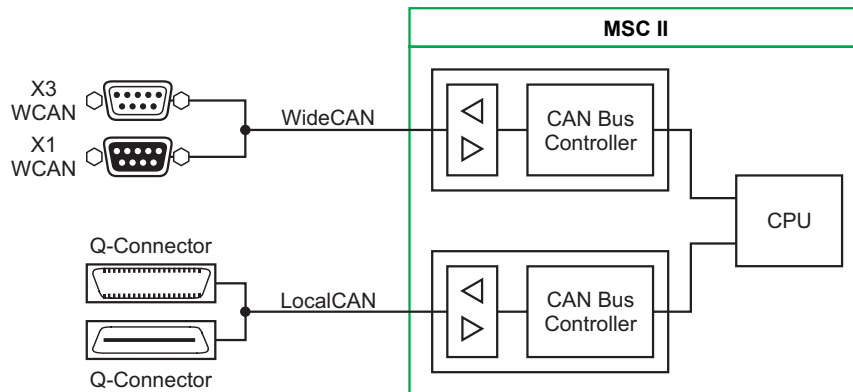

Figure 71: CAN Bus Interfaces of the MSC II

Although both CAN bus interfaces are equally fast and have equal priority, WideCAN is typically used for communication between all the network stations of a wide area automation system, while LocalCAN is preferred for rapid local communication between fewer network stations.

- ⓘ The «WCAN» and «LCAN» front panel status LEDs of the MSC II flash synchronously to the flow of data that the MSC II is sending over the WideCAN or LocalCAN interface, respectively.

The «WCAN» front panel connectors are connected internally 1:1 with each other. As a result, the MSC II control module can be connected directly to the CAN bus without a T-adapter.

The functionality of the CAN bus interfaces is defined in the application program.

Information about CAN bus and CANopen:

⇒ ["7.5 CAN Bus and CANopen" on page 55](#)

Information about the CAN bus interface cable:

⇒ ["7.5.6 CAN Bus Interface Cable" on page 59](#)

**CAN Bus Interfaces
of the MSC II control
module**

**CAN Bus Interfaces
of the MSC II**

**Status LEDs «WCAN» and
«LCAN» of the
MSC II**

10.15.1 CAN Bus Termination Resistor

The LocalCAN interface of the MSC II is equipped with a switchable CAN bus termination resistor. The termination resistor can be switched on by a MACS function block in the application project.

-  The «TRM» front panel status LED of the MSC II illuminates when the termination resistor of the LocalCAN interface is switched on.
⇒ ["10.4.2 LEDs" on page 81](#)

The switchable CAN bus termination resistor of the MSC II can be used as a termination resistor only on LocalCAN bus groups.

⇒ ["7.7.3 LocalCAN Bus Groups" on page 66](#)

In WideCAN bus groups, the switchable CAN bus termination resistor of the MSC II **cannot** be used as a termination resistor! Separate pluggable CAN termination resistors must be used for this.

⇒ ["7.7.4 WideCAN Bus Groups" on page 67](#)

-  D-sub connectors with CAN bus termination resistors are available from Moog.

⇒ ["11.7 CAN Bus Accessories" on page 120](#)

10.15.2 Setting the CANopen Node-ID

The CANopen node-ID of the CAN bus interface of the MSC II control module can be set or modified in the following places:

- In the application program
- With the PLC Browser in the MACS development environment

The CANopen node-ID is saved in the license key.

⇒ ["10.6.2 CANopen Node-ID and IP Address" on page 86](#)

10.15.3 Setting the CAN Bus Baud Rate

The CAN bus baud rate is set in the application program.

CAN Bus Termination Resistor of the MSC II

Setting/Modifying MSC II control module's CANopen Node-ID

10.16 Serial Interfaces

The MSC II provides the following serial interface:

- **SIO interface** with «SIO» front panel connector
SIO interface according to TIA/EIA 232 (previously RS 232):

 The SIO interface's communication parameters are set in the application program.

Terminal assignment of the serial interfaces:

⇒ "10.4.1 Terminal Assignment" on page 78

Serial interface cables:

⇒ "7.4 Serial TIA/EIA Interface Cables" on page 54

Serial Interfaces of the MSC II

10.17 Safety Functions

10.17.1 Watchdog

The MSC II control module provides a function for monitoring whether the software is working properly. When there is a fault, this function switches all digital outputs to zero potential condition and stops fieldbus communication. As a result, the user can set up systems that have a greatly reduced risk of fatal malfunctions.

In the MSC II control module, this function is implemented in the M_WATCHDOG function block, which can be used in the application program to be monitored. If this function block is used, it must be enabled and triggered cyclically in order to keep the outputs enabled.

When there is a fault (when the application program can no longer trigger the function block within the set time period), the outputs will be disabled.

If the M_WATCHDOG function block is not used in the application program, the MSC II control module's watchdog will not operate. In this case, the outputs will always be enabled and they will output the value calculated in the application program.

 The digital output 'Outputs Enabled' indicates the enabled state of all digital outputs and the MSC II's E-bus and fieldbus communication.

Watchdog of the MSC II control module

10.17.2 'Outputs Enabled' Output (LED «OutEN»)

WARNING



If there is a defect in an output stage, the 'Outputs Enabled' signal will not necessarily shut down all of the outputs securely.

'Outputs Enabled' Output (LED «OutEN») of the MSC II control module

The digital output 'Outputs Enabled' indicates the enabled state of all digital outputs and the MSC II's E-bus and fieldbus communication. It can be used to signalize another controller that all of the MSC II control module's outputs were disabled.

As long as the 'Outputs Enabled' output is in the 1 state, the application program will control all outputs, the E-bus communication and the fieldbus communication.

If the 'Outputs Enabled' output is switched to the 0 state (LED «OutEN» does not illuminate), all outputs will be disabled, the E-bus communication and the fieldbus communication will be stopped.

In this case, although the internal states of the digital outputs are shown on the front panel status LEDs «I/O1»...«I/O4» of the MSC II control module, they are not connected through to the output.

The digital output 'Outputs Enabled' will be switched to the 1 state only if the following conditions are fulfilled simultaneously:

- An error-free application program has been loaded onto the MSC II control module and will be started once after every reset of the MSC II control module
- A valid license key is inserted
- The M_WATCHDOG function block is not used
or the M_WATCHDOG function block is used in the application program, enabled and triggered cyclically within the set time

If any one of these conditions is not fulfilled, the 'Outputs Enabled' output will be switched to the 0 state, thereby disabling all of the MSC II control module's other outputs. In addition, the E-bus and the fieldbus communication will be stopped.

10.17.2.1 «OutEN» LED

The front panel LED «OutEN», located of the MSC II control module, indicates the status of the 'Outputs Enabled' output. The LED «OutEN» illuminates when the 'Outputs Enabled' output is in the 1 state.

«OutEN» LED of the
MSC II control module

10.17.3 Stopping the Application Program

An application program (executed in the MSC II control module) can be stopped in the MACS development environment.

After an application program stops, all analog and digital outputs will automatically be switched to a secure state. This secure value can be set for each output individually by modifying the 'Secure' channel parameter in the PLC Configuration.

Stopping the
Application Program

- ⓘ If the «OutEN» LED does not illuminate (when the 'Outputs Enabled' output is in the 0 state), this secure value will **not** be at the outputs because the outputs will be disabled.

⇒ ["10.17.2 'Outputs Enabled' Output \(LED «OutEN»\)" on page 111](#)

10.18 Nameplate

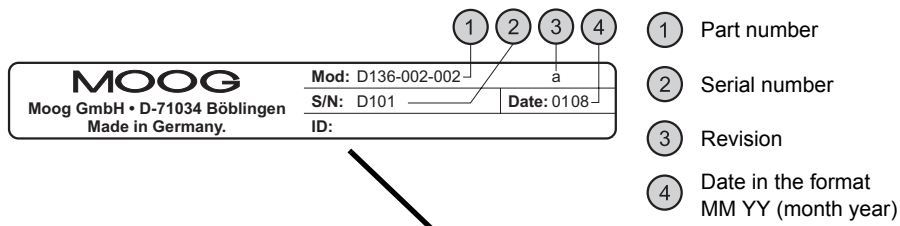

Nameplate of the MSC II

- ① Part number
- ② Serial number
- ③ Revision
- ④ Date in the format MM YY (month year)

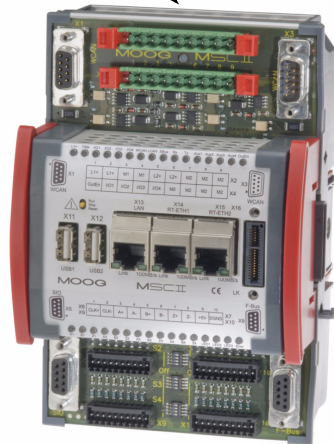

Figure 72: Position of the Nameplate on the MSC II

11 Product Range

- i** The following chapter describes only a small part of Moog's extensive product range. In addition to the many different M3000® modules, Moog's current product range includes a large variety of accessories.

11.1 M3000® Starter Kits

Item Designation	Remarks	Part Number
MSC I starter kit, including MSC I with Profibus-DP slave	Complete package including everything needed to get started	D147-001-005
MSC II starter kit, including MSC II with Profibus-DP slave interface	Complete package including everything needed to get started ⇒ "3.2 MSC II Starter Kit" on page 15	D147-002-001
MSC II starter kit, including MSC II with dual EtherCAT master interface	Complete package including everything needed to get started ⇒ "3.2 MSC II Starter Kit" on page 15	D147-002-002
MSD starter kit including one MSD Motion Controller and one 4A MSD Servodrive	Complete package including everything needed to get started ⇒ "3.2 MSC II Starter Kit" on page 15	Ordering number not assigned yet

**Product Range:
M3000® Starter Kits**

Table 23: Product Range – M3000® Starter Kits



11.2 M3000® Modules

11.2.1 Controller

Product Range: Controller

Item Designation	Remarks	Part Number
MSC II	Multi-axis high performance motion controller with PLC functionality 128 MB RAM / 32 MB Flash 4 Digital I/O 4 Position transducer interfaces 2 USB, 1 Ethernet, 2 CAN, 1 TIA/EIA 232 ⇒ "3.3.2 MSC II" on page 17	D136-002-002
MSC II with Profibus-DP interface	As D136-002-002, additional Profibus-DP slave interface ⇒ "3.3.2 MSC II" on page 17	D136-002-001
MSC II with EtherCAT interface	As D136-002-002, additional dual EtherCAT master interface ⇒ "3.3.2 MSC II" on page 17	D136-002-003
MSD Motion Controller	Multi-axis high performance motion controller with PLC functionality 128 MB RAM / 32 MB Flash 4 Digital I/O 1 USB, 1 Ethernet, 1 CAN, 2 EtherCAT master ⇒ "3.3.5 MSD Motion Controller" on page 22	G391-001-001
MSD Motion Controller with Profibus-DP interface	As G391-001-001, additional Profibus-DP slave interface ⇒ "3.3.5 MSD Motion Controller" on page 22	G391-001-002
MSC I Motion Controller	Multi-axis high performance motion controller with PLC functionality 4 MB RAM / 4 MB Flash 8 Digital I/O 8 Analog In (16bit), 2 Analog Out (16bit) 2 Position transducer interface 2 CAN Controller, 1 TIA/EIA 232	D136-001-008
MSC I Motion Controller with Profibus-DP interface	As D136-001-008, additional Profibus-DP slave interface	D136-001-007

Table 24: Product Range – Controller

-  The plug-in terminal strips, that may be needed for connection of power and signal cables, are not included in delivery. The plug-in terminal strips are available from Moog as accessories. Only the MSD Motion Controller is delivered with the necessary plug-in terminal strips for power supply and digital I/O.
⇒ "11.8 Plug-In Terminal Strips" on page 121
-  The MSC II control module does not work without license key. This license key is not included in the standard delivery. It is available from Moog as an accessory.
⇒ "11.4 License Keys" on page 118

11.2.2 Q-Modules

Product Range: Q-Modules

Item Designation	Remarks	Part Number
QDIO 16/16-0,5	Digital I/O extension module for local extension of the inputs and outputs of MSC I, MSC II or RDIO (connection over E-bus) 16 inputs and 16 I/Os Positive switching ⇒ "3.3.3 Q-Modules" on page 17	D137-001-005
QDIO 16/16-0,5N	Digital I/O extension module for local extension of the inputs and outputs of MSC I or MSC II (connection over E-bus) 16 inputs and 16 I/Os Zero switching ⇒ "3.3.3 Q-Modules" on page 17	D137-001-004
QAIO 2/2-AV	Analog I/O extension module for local extension of the inputs and outputs of MSC I or MSC II (connection over E-bus) 2 inputs (± 10 V/ ± 10 mA/ 4–20 mA) 2 outputs (± 10 V/ ± 10 mA/ 4–20 mA/ ± 50 mA) ⇒ "3.3.3 Q-Modules" on page 17	D137-001-011
QAIO 16/4-V	Analog I/O extension module for local extension of the inputs and outputs of MSC I or MSC II (connection over E-bus) 16 voltage inputs (± 10 V) 4 voltage outputs (± 10 V) ⇒ "3.3.3 Q-Modules" on page 17	D137-001-007
QAIO 16/4-A	Analog I/O extension module for local extension of the inputs and outputs of MSC I or MSC II (connection over E-bus) 16 current inputs (0–20 mA) 4 voltage outputs (± 10 V) ⇒ "3.3.3 Q-Modules" on page 17	D137-001-006
QEBUS-CAN	CAN extension module which can be used to make available the LocalCAN bus of an E-bus group for external CAN bus network stations (over a D-sub front panel connector) ⇒ "3.3.3.2 QEBUS-CAN" on page 19	D137-001-010

Table 25: Product Range – Q-Modules

- i** The plug-in terminal strips, that may be needed for connection of power and signal cables, are not included in delivery. The plug-in terminal strips are available from Moog as accessories. Only the MSD Motion Controller is delivered with the necessary plug-in terminal strips for power supply and digital I/O.
⇒ "11.8 Plug-In Terminal Strips" on page 121

11.2.3 R-Modules (Remote Modules)

Item Designation	Remarks	Part Number
RDIO 16/16-0,5	Remote module with digital I/Os and CANopen interface (connection over CAN bus) 16 inputs and 16 I/Os Positive switching ⇒ "3.3.4 R-Modules (Remote Modules)" on page 19	D137-002-001
RDISP 22	Display and operating terminal with TIA/EIA 232 and CANopen interface and 22 keys (connection over CAN bus) ⇒ "3.3.4 R-Modules (Remote Modules)" on page 19  The CPRDISP software (needed to program and configure the RDISP) is not included with RDISP. CPRDISP is available from Moog as an accessory. ⇒ "11.5.2 Software for R-Modules" on page 119	D137-004-001
DialogController	Displays with TFT technology and touch screen. Programmable with MACS development environment. Data exchange via Ethernet with MSC or MSD Motion Controller Display 5.7" Display 10.4" Display 12.1"	D137-004-004 D137-004-005 D137-004-006

**Product Range:
R-Modules
(Remote Modules)**

Table 26: Product Range – R-Modules (Remote Modules)

-  The plug-in terminal strips, that may be needed for connection of power and signal cables, are not included in delivery. The plug-in terminal strips are available from Moog as accessories. Only the MSD Motion Controller is delivered with the necessary plug-in terminal strips for power supply and digital I/O.
⇒ "11.8 Plug-In Terminal Strips" on page 121

11.3 Power Supply for M3000® Modules

Item Designation	Remarks	Part Number
Power supply 24 V 10 A	Power-supply for mounting on DIN top-hat rails with short-circuit protection Input: 230 V AC or 115 V AC Output: 24 V DC, 10 A max.	D137-003-001

**Product Range:
Power Supply for
M3000® Modules**

Table 27: Product Range – Power Supply for M3000® Modules

11.4 License Keys

Item Designation	Remarks	Part Number
License key Controls	gray	D138-002-001
License key Motion	green	D138-002-002

Table 28: Product Range – License Keys

**Product Range:
License Keys**

Feature	License Key	
	Controls (Gray)	Motion (Green)
Run-time license of the MSC II	•	•
CoDeSys operators and standard IEC 61131 library	•	•
Library with hardware-related functions: M_HW_MSC II.Lib	•	•
Library for control engineering: M_Control.Lib	•	•
Library for the TIA/EIA 232 and CAN bus interface: M_SIO.Lib	•	•
Support for OPC and DDE interfaces	•	•
Ethernet and TIA/EIA 232 communication with the MACS development environment	•	•
Library for motion control according to PLCopen: M_PLCopen.Lib		•
Library with transfer functions (Z-functions): M_Transfer_Functions.Lib		•
Libraries for CANopen, Profibus DP		•

• Feature included

License Keys: Features

Table 29: Features Provided by the License Keys

-  The MSC II control module does not work without license key.
 ⇒ ["3.4 License Key" on page 24](#)
 ⇒ ["10.6 License Key" on page 85](#)

11.5 Software

11.5.1 MACS (Moog Axis Control Software)

Item Designation	Remarks	Part Number
MACS development environment	Development environment according to IEC 61131 for solving complex control tasks (1 license) ⇒ "3.5 Application Programs" on page 25	D138-001-001
	1 additional license	D138-001-002
	5 licenses	D138-001-005
	10 licenses	D138-001-010
MACS HMI	Visualization package which can be run without MACS Run-time license for 1 system ⇒ "3.6.1 MACS HMI Visualization Package" on page 26	D138-003-001
	Run-time license for 10 systems	D138-003-010
	Run-time license for 50 systems	D138-003-050
Software maintenance contract	Support and MACS updates for 1 year (for 1 license)	B95914-001-001
	1 additional license	B95914-001-002
	5 licenses	B95914-001-005
	10 licenses	B95914-001-010

**Product Range:
Software – MACS**

Table 30: Product Range – Software – MACS

11.5.2 Software for R-Modules

Item Designation	Remarks	Part Number
CPRDISP	Software for programming and configuring RDISP ⇒ "3.3.4.2 RDISP" on page 20	D138-006-001

**Product Range:
Software for R-Modules**

Table 31: Product Range – Software for R-Modules

11.6 Interface Cables

Item Designation	Remarks	Part Number
Crossed TIA/EIA 232 interface cable, 5 m (5.47 yd)	Null modem cable which can be used as programming cable for connecting the MSC I and PC (MACS) with 9 pole D-sub mating connectors ⇒ figure 42 on page 54	B95884-001
Crossed Ethernet interface cable, 10 m (10.94 yd)	100BaseT Cable with Crossed Twisted Pair Wires (Crossover Cable) with 8 pole RJ45 mating connectors ⇒ figure 35 on page 48	B95909-001
Non-crossed Ethernet interface cable, 1 m (1.09 yd)	100BaseT Cable with Non-Crossed Twisted Pair Wires (Patch Cable) with 8 pole RJ45 mating connectors ⇒ figure 36 on page 48	B95909-004
Non-crossed Ethernet interface cable, 10 m (10.94 yd)	100BaseT Cable with Non-Crossed Twisted Pair Wires (Patch Cable) with 8 pole RJ45 mating connectors ⇒ figure 36 on page 48	B95909-002
CAN bus interface cable, 3 m (3.28 yd)	⇒ "7.5.6 CAN Bus Interface Cable" on page 59	B95863-001
CAN bus interface cable, 10 m (10.94 yd)	⇒ "7.5.6 CAN Bus Interface Cable" on page 59	B95863-002

Table 32: Product Range – Interface Cables

**Product Range:
Interface Cables**

11.7 CAN Bus Accessories

Item Designation	Remarks	Part Number
USB CAN adapter (for PC only)	Adapter (USB1.1 to CAN bus) with 9 pole D-sub mating connector with pin contacts	C43094-001
CAN bus termination resistor 120 Ω	9 pole D-sub mating connector with socket contacts	B95864-001
CAN bus termination resistor 120 Ω /GND	9 pole D-sub mating connector with pin contacts; CAN_GND internally connected to signal ground	B95865-001

Table 33: Product Range – CAN Bus Accessories

**Product Range:
CAN Bus Accessories**

11.8 Plug-In Terminal Strips

**Product Range:
Plug-In Terminal Strips
for DIN Rail Modules**

Item Designation	Remarks	Part Number
Plug-in terminal strip with screw terminals	2 pole (up to max. 2.5 mm ² (14 AWG) wire cross section)	VK055-002
	8 pole (up to max. 2.5 mm ² (14 AWG) wire cross section)	VK055-008
	9 pole (up to max. 2.5 mm ² (14 AWG) wire cross section)	VK055-009
	18 pole (up to max. 2.5 mm ² (14 AWG) wire cross section)	VK055-018
Plug-in terminal strip with spring loaded terminals	2 pole (up to max. 2.5 mm ² (14 AWG) wire cross section)	B95907-002
	8 pole (up to max. 2.5 mm ² (14 AWG) wire cross section)	B95907-008
	9 pole (up to max. 2.5 mm ² (14 AWG) wire cross section)	B95907-009
	18 pole (up to max. 2.5 mm ² (14 AWG) wire cross section)	B95907-018
Labels for plug-in terminal strips	For labeling plug-in terminal strips Printed with the numbers 1–108 Includes six labels	B95885-001
Insertion bridge	For connecting adjoining terminals of the plug-in terminal strips	A69102
Coding tab	For coding plug-in terminal strips	C43145-001
Coding profile	For coding plug-in terminal strip connectors of M3000® modules	C43146-001
Spring power clamp 10-pins	Spring latch terminal for max 0,5 mm ² wires (20 AWG)	CA45260-010
Connector kit for MSD Motion Controller	2 x FMC 1,5/7-ST-3,5GY 2 x MSTB 2,5/2-ST GY Mating connectors for the MSD Motion Controller X3, X9 and X10	CA65115-001

Table 34: Product Range – Plug-In Terminal Strips

The various DIN rail modules require different numbers of plug-in terminal strips.

⇒ ["11.8.1 Number of Required Plug-In Terminal Strips" on page 122](#)

11.8.1 Number of Required Plug-In Terminal Strips

DIN Rail Module	Number of Plug-In Terminal Strips Required			
	2 Poles	9 Poles	10 Poles	18 Poles
MSC I	-	1	-	5
MSC II	-	2	4	-
MSD Motion Controller	-	-	-	-
QDIO	-	-	-	6
QAIO 2/2	-	1	-	2
QAIO 16/4	-	-	-	6
QEBUS-CAN	1	-	-	-
RDIO	-	-	-	6
RDISP	-	-	-	-
DialogController	-	-	-	-

**Number of Required
Plug-In Terminal Strips**

Table 35: Number of Plug-In Terminal Strips

The MSD Motion Controller is delivered with the necessary plug-in terminal strips for power supply and digital I/O.

11.9 Training Programs

Product Range: Training Programs

Item Designation	Remarks	Part Number
Software training, English MACS and IEC 61131	Content of the training: <ul style="list-style-type: none"> • Programming, testing, optimizing, and documenting IEC 61131 application programs • Visualization of IEC 61131 application programs 	B95992
Software training, German MACS and IEC 61131	Content of the training: <ul style="list-style-type: none"> • Programming, testing, optimizing, and documenting IEC 61131 application programs • Visualization of IEC 61131 application programs 	B95993
Hardware training, English MSC II and extension modules	Content of the training: <ul style="list-style-type: none"> • Configuring and using MSC II and extension modules • Using control-engineering libraries <p>Knowledge about creating IEC 61131 application programs is required to participate in the hardware training. This knowledge is imparted in the MACS and IEC 61131 software training.</p>	B95994
Hardware training, German MSC II and extension modules	Content of the training: <ul style="list-style-type: none"> • Configuring and using MSC II and extension modules • Using control-engineering libraries <p>Knowledge about creating IEC 61131 application programs is required to participate in the hardware training. This knowledge is imparted in the MACS and IEC 61131 software training.</p>	B95995
Hardware and Software training, English MSD Servodrives and MSD Motion Controller	Content of the training: <ul style="list-style-type: none"> • MSD Servo Drive Hardware • MSD Servo Drive Software • MSD Motion Controller <p>Knowledge about creating IEC 61131 application programs is recommended to participate in the hardware training. This knowledge is imparted in the MACS and IEC 61131 software training.</p>	CA67627
Hardware and Software training, German MSD Servodrives and MSD Motion Controller	Content of the training: <ul style="list-style-type: none"> • MSD Servodrive Hardware • MSD Servodrive Software • MSD Motion Controller <p>Knowledge about creating IEC 61131 application programs is recommended to participate in the hardware training. This knowledge is imparted in the MACS and IEC 61131 software training.</p>	CA67628

Table 36: Product Range – Training Programs

12 Appendix

12.1 Typographical Conventions

DANGER



Identifies safety instructions that are intended to warn of an immediate and impending danger to life and limb or major property damage.

Failure to observe these safety instructions will lead inevitably to death, serious personal injury (disablement) or major property damage!

Typographical Conventions

WARNING



Identifies safety instructions that are intended to warn of potential danger to life and limb or the potential for major property damage.

Failure to observe these safety instructions might lead to death, serious personal injury (disablement) or major property damage!

CAUTION



Identifies safety instructions that are intended to warn of slight personal injury or minor property damage.

Failure to observe these safety instructions might lead to slight personal injury or minor property damage.

• / –

Identifies listings



Identifies references to another chapter, another page, table or figure in this manual

blue text

Identifies a hyperlink within the PDF file



Identifies important information

1., 2., ...

Identifies steps in a procedure that should be performed in consecutive order

①, ②, ...

Identifies items in a figure that are explained separately

«WCAN»

Identifies terminals or connectors (such as: «WCAN») and light emitting diodes (such as: «I/O1») of an M3000® module

'Frequency'

Identifies parameters of the MACS development environment (such as: 'Frequency') and outputs of M3000® modules (such as: 'Outputs Enabled')

12.2 Abbreviations

Abbreviation	Explanation
AC	Alternating Current
ADC	Analog to Digital Converter
CAL	CAN Application Layer according to CiA DS 201–207
CAN	Controller Area Network
CAN_GND	CAN Ground
CAN_H	CAN High (CAN bus signal (dominant high))
CAN_L	CAN Low (CAN bus signal (dominant low))
CAN_SHLD	CAN Shield (optional shield)
CFC	Continuous Function Chart (random-graphics functional chart editor; programming language for creating PLC programs)
CiA	CAN in Automation e. V. (international organization of manufacturers and users for CAN users; http://www.can-cia.org)
CLK	Clock
CPU	Central Processing Unit
DAC	Digital to Analog Converter
DC	Direct Current
DGND	Digital Ground (Ground for the digital I/Os' power supply of the MSC II)
DIN	Deutsches Institut für Normung e. V. (German Institute for Standardization; http://www.din.de)
DIS	Draft International Standard (preliminary standard)
DS	Draft Standard (draft standard)
E-bus	Extension bus of DIN rail modules
EEPROM	Electrically Erasable Programmable Read Only Memory
EIA	Electronic Industries Alliance (http://www.eia.org)
EMC	Electromagnetic Compatibility
EN	Europa-Norm (European Standard)
EPROM	Erasable Programmable Read Only Memory
ESD	Electrostatic Discharge
EtherCAT	Ethernet-based industrial real-time communication system
FBD	Function Block Diagram (programming language for creating PLC programs)
F-Bus	Fieldbus, an industrial communication system such as Profibus
Flash EEPROM	High speed EEPROM
FPGA	Field Programmable Gate Array (programmable logic component)
GUI	Graphical User Interface
HF	High Frequency
HMI	Human Machine Interface (MACS HMI: Visualization package which can be run without MACS)
ID	Identifier
IEC	International Electrotechnical Commission (http://www.iec.ch)
IEEE	Institute of Electrical and Electronics Engineers, Inc. (http://www.ieee.org)
IL	Instruction List (programming language for creating PLC programs)
I/O	Input/Output
IP	International Protection (protection type)
IP	Internet Protocol
ISO	International Organization for Standardizing (http://www.iso.org)
LAN	Local Area Network

Table 37: Abbreviations

Table 37: Abbreviations (Section 1 of 3)

Abbreviation	Explanation
LCD	Liquid Crystal Display
LD	Ladder Diagram (programming language for creating PLC programs)
LED	Light Emitting Diode
LSB	Least Significant Bit
M3000®	Moog Automation System
MACS	Moog Axis Control Software (Development environment according to IEC 61131 for solving complex control tasks)
Mbit/s	Megabits per second
MSB	Most Significant Bit
MSC I	Moog Servo Controller I (Control module for DIN top-hat rail mounting)
MSC II	Moog Servo Controller II (Control module for DIN top-hat rail mounting)
MSD	Modular Multi-Axis Programmable Motion Control Servodrive
MSD Motion Controller	Multi-Axis High Performance Motion Controller
MSD Servodrive	A modular family of electrical servo drives to run permanent magnet synchronous, linear and asynchronous motors
MSL	Mean Sea Level
NC	Not Connected
ND	Not Defined
PADT	Programming And Diagnostic Tool (programming and diagnostic tool in IEC 61131, here: PC on which the MACS development environment is installed)
PC	Personal Computer
PE	Protective Earth
PLC	Programmable Logic Control(ler)
Q-Modules	DIN rail modules for local extension of MSC IIs (connected over E-bus)
Q-Connector	40 pole lateral connector of DIN rail modules
QAIO	Analog I/O extension module for local extension of the inputs and outputs of MSC I or MSC II (connection over E-bus)
QEBUS-CAN	CAN extension module which can be used to make available the LocalCAN bus of an E-bus group for external CAN bus network stations (over a D-sub front panel connector)
QDIO	Digital I/O extension module for local extension of the inputs and outputs of MSC I or MSC II (connection over E-bus)
R-Modules	Remote modules such as RDIO and RDISP (connection over CAN bus)
RAM	Random Access Memory (read and write memory that loses its contents when power is removed)
RDIO	Remote module with digital I/Os and CANopen interface (connection over CAN bus)
RDISP	Remote Display (display and operating terminal with TIA/EIA 232 and CANopen interface (connection over CAN bus))
REF	Reference voltage
RISC	Reduced Instruction Set Computer
RT-ETH	Real Time Ethernet Interface
Rx	Receive Data
SELV	Safety Extra-Low Voltage (according to DIN EN 60950-1)
SFC	Sequential Function Chart (programming language for creating PLC programs)
SHLD	Shield
SIO	Serial I/O (serial interface of the MSC II)

Table 37: Abbreviations

Table 37: Abbreviations (Section 2 of 3)

Abbreviation	Explanation
SSI	Synchronous Serial Interface (digital interface for transferring positioning information, like with position transducers)
ST	Structured Text (programming language for creating PLC programs)
TIA	Telecommunications Industry Association (http://www.tiaonline.org)
TPU	Time Processing Unit (programmable microprocessor that processes time functions independently of the CPU)
TÜV	Technischer Überwachungsverein (German agency performing technical inspections)
Tx	Transmit Data
USB	Universal Serial Bus
V DC	Volt Direct Current (unit of direct voltage)
VDE	Verband der Elektrotechnik Elektronik Informationstechnik (Association for Electrical, Electronic & Information Technologies; http://www.vde.de)
VDMA	Verband Deutscher Maschinen- und Anlagenbau e. V. (Federation of Engineering Industries; http://www.vdma.org)
WCAN	WideCan
WF	Wire Fault

Table 37: Abbreviations (Section 3 of 3)

Table 37: Abbreviations

12.3 Quoted Standards

12.3.1 CiA DS

CiA DS 201–207

CiA Draft Standard: CAN Application Layer (CAL)

Quoted Standards: CiA DS

CiA DS 301

CiA Draft Standard: CANopen Communication Profile for Industrial Systems – Based on CAL

CiA DS 401

CiA Draft Standard: CANopen Device Profile for Generic I/O Modules

12.3.2 DIN

DIN 41652

Rack and Panel Connectors, Trapezoidal, Round Contacts 1 mm

Quoted Standards: DIN

12.3.3 DIN EN

DIN EN 60715

Dimensions of Low Voltage Switchgear and Controlgear – Standardized Mounting on Rails for Mechanical Support of Electrical Devices in Switchgear and Controlgear Installations

Quoted Standards: DIN EN

DIN EN 60950-1

Information Technology Equipment – Safety – Part 1: General Requirements

DIN EN 61000-6-1

Electromagnetic Compatibility (EMC) – Part 6-1: Generic Standards; Immunity for Residential, Commercial and Light-Industrial Environments

DIN EN 61000-6-2

Electromagnetic Compatibility (EMC) – Part 6-2: Generic Standards: Immunity for Industrial Environments

DIN EN 61000-6-3

Electromagnetic Compatibility (EMC) – Part 6-3: Generic Standards; Emission Standard for Residential, Commercial and Light-Industrial Environments

DIN EN 61000-6-4

Electromagnetic Compatibility (EMC) – Part 6-4: Generic Standards; Emission Standard for Industrial Environments

DIN EN 60204

Safety of Machinery – Electrical Equipment of Machines

12.3.4 IEC**IEC 60068**

Environmental Testing

Quoted Standards: IEC

IEC 60068-2-6

Environmental Testing – Part 2: Tests; Test Fc: Vibration (Sinusoidal)

IEC 60068-2-27

Environmental Testing – Part 2: Tests; Test Ea and Guidance: Shock

IEC 60068-2-31

Environmental Testing – Part 2: Tests; Test Ec: Drop and Topple, Primarily for Equipment-Type Specimens

IEC 60364-4-44

Electrical Installations of Buildings – Part 4-44: Protection for Safety – Protection against Voltage Disturbances and Electromagnetic Disturbances

IEC 60529

Degrees of Protection Provided by Enclosures (IP Code)

IEC 60664

Insulation Coordination for Equipment within Low Voltage Systems

IEC 60801-2

Electromagnetic Compatibility for Industrial-Process Measurement and Control Equipment – Part 2: Electrostatic Discharge Immunity Requirements

IEC 61131

Programmable Controllers

IEC 61131-1

Programmable Controllers – Part 1: General Information

IEC 61131-2

Programmable Controllers – Part 2: Equipment Requirements and Tests

IEC 61131-3

Programmable Controllers – Part 3: Programming Languages

IEC 61131-4

Programmable Controllers – Part 1: User Guidelines

12.3.5 ISO/DIS**ISO/DIS 11898**

Road Vehicles – Controller Area Network (CAN)

**Quoted Standards:
ISO/DIS**

12.3.6 TIA/EIA

TIA/EIA 232 (previously RS 232)

Interface Between Data Terminal Equipment and Data Circuit – Terminating Equipment Employing Serial Binary Data Interchange

**Quoted Standards:
TIA/EIA**

TIA/EIA 422 (previously RS 422)

Electrical Characteristics of Balanced Voltage Digital Interface Circuits

TIA/EIA 485 (previously RS 485)

Electrical Characteristics of Generators and Receivers for Use in Balanced Digital Multipoint Systems

13 Index

A

«A1»...«A4», see LEDs of the MSC II

Abbreviations used • 125

Accessories, see product range

Air humidity, relative

- permissible for operating the MSC II • 75
- permissible for transportation and storage
 - M3000® modules • 71
 - MSC II • 75

Air pressure, permissible

- for transportation and storage
 - M3000® modules • 71
 - MSC II • 75

Ambient temperature

- permissible for operating the MSC II • 75
- permissible for transportation and storage
 - M3000® modules • 71
 - MSC II • 75

Application programs

- creating with MACS • 25

Arrangement of DIN rail modules

- between cable conduits • 32
- minimum distances between control groups • 32
- on a vertical mounting plate • 31

Attachment screws for the license key, see license key

attachment screws

«Aux1»...«Aux4», see LEDs of the MSC II

B

«B1»...«B4», see LEDs of the MSC II

Basetick • 90–92

- cycle time • 91
- E-bus start time • 91
- SSI sensor start time • 91
- task reaction time • 92
- timing diagram • 91

Basic wiring diagram

- digital input of the MSC II • 97
- digital output of the MSC II • 95

Block diagrams

- Block Diagram of the MSC II • 76

Booting the MSC II, see resetting the MSC II

Brands, see trademarks

C

CAN bus • 55–60

- characteristics • 55
- linear structure • 58

CAN bus accessories

- part numbers • 120

CAN bus interface cables,

- see interface cables: CAN bus interface cables

CAN bus interfaces

- MSC II • 56, 64, 109–110
 - CANopen node-ID • 86, 110
 - «LCAN» (LED of the MSC II for displaying LocalCAN transmission activity • 81, 109
 - «WCAN» (LED of the MSC II for displaying WideCAN transmission activity • 81, 109
 - «WCAN» (MSC II front panel connectors) • 77, 109
 - terminal assignment • 78
- Q-modules • 56, 64
- R-modules • 56, 64

CAN bus network node, see CAN bus network stations

CAN bus networks

- permissible cable lengths • 59
- permissible number of network stations • 58
- permissible stub cable lengths • 59
- potential equalization • 57, 58
- suitable cables • 60
- wiring • 57

CAN bus network stations

- permissible number of network stations • 58

CAN bus termination resistors • 57, 58

- part numbers • 120

termination resistor of the MSC II

- switchable termination resistor of the LocalCAN interface • 110

- «TRM» (LED of the MSC II) (indicates that the resistor is switched on) • 81

CAN extension module, see Q-modules: QEBUS-CAN

CANopen • 56

- CANopen node-ID of the MSC II • 86, 110
- profiles for various device classes • 56

CE labeling of the M3000® modules • A, 4

Cleaning

- safety instructions • 9, 69

Communication between MSC II and MACS • 84

- MACS communication parameters
 - Ethernet interface • 84
- safety instructions • 11, 84

Configuration of the MSC II • 84

Connector assignment, see terminal assignment

Contamination level

- M3000® modules • 71
- MSC II • 75

Control groups

- E-bus groups • 65
- LocalCAN bus groups • 66
- WideCAN bus groups • 67

Control module, see MSC II

Control system, see M3000®

Copying prohibition for this manual • A

Copyright

- for software that is installed on M3000® products • 5
- for this manual • A

Corrosion, insensitivity to see insensitivity to corrosion

CPRDISP, see R-modules: software for R-modules

Current, maximum admissible current for the power supply terminals of M3000® modules • 43

Cycle time • 90–92

D**Data retention of the MSC II** • 73**Development environment**, see MACS**Dialog Controller** • 21**Dimensions**

DIN rail modules • 30

MSC II • 73, 74

DIN rail modules

arrangement

between cable conduits • 32

on a vertical mounting plate • 31

dimensions • 30

front view • 29

minimum distances between control groups • 32

mounting on DIN top-hat rails • 33

networking • 64–68

control groups

E-bus groups • 65

LocalCAN bus groups • 66

WideCAN bus groups • 67

removing from the DIN top-hat rail • 36

views of the module • 29

DIN top-hat rail TH 35-7.5 • 31**Disclaimer**

liability, see liability: exclusion of liability

warranty, see warranty: exclusion of warranty

Display and operating terminal, see R-modules: RDISP**Disposing M3000® modules** • 4**Disturbance suppression of digital inputs** • 97**Drop height, permissible**

M3000® modules • 71

MSC II • 75

Duplication prohibition for this manual • A**E****E-bus** • 60–63

clock frequency • 62

configuration in the PLC configuration of MACS • 108

«EBus», see LEDs of the MSC II

E-bus communication

duration of message transmission • 62

example • 63

message update rate • 62

safety instructions • 62

scope of the E-bus messages • 63

starting the communication within E-bus groups • 61

E-bus groups • 65

permissible masters • 61

permissible slaves • 61

E-bus interfaces

MSC II • 64, 108

«EBus» (LED of the MSC II for displaying E-bus transmission activity) • 81

Q-modules • 64

R-modules • 64

E-bus start time • 91**Electromagnetic Compatibility** • 4**EMC** • 4**Emissions**, see environmental protection**Environmental conditions**

for operating M3000® modules • 27

for operating the MSC II • 75

climatic conditions • 75

electrical conditions and requirements • 75

mechanical conditions and requirements • 75

for transporting and storing M3000® modules • 71

limitations of using M3000® modules • 28

requirements from IEC 61131-2 • 27

safety instructions • 7, 27, 74

Environmental protection

disposing M3000® modules • 4

no harmful emissions from M3000® modules (when used properly) • 4

«Error», see LEDs of the MSC II

ESD

safety instructions • 7

EtherCAT • 49

Bus topology • 49

interface cable • 49

Ethernet

communication between MSC II and MACS

communication parameters of the Ethernet

interface • 84

Ethernet interface of the MSC II • 72

communication parameters • 84

terminal assignment • 80

IP address of the MSC II • 84, 86

LEDs of the MSC II

«Link» (displays Ethernet link pulse and activity) • 82

«Speed» (displays Ethernet connection speed) • 82

networks

with exactly 2 network stations • 47

with more than 2 network stations • 48

Ethernet interface cables,

see interface cables: Ethernet interface cables

Ethernet LAN connector • 80**Ethernet RT-ETH1 connector** • 81**Ethernet RT-ETH2 connector** • 81**Extension modules**

CAN extension module, see Q-modules: QEBUS-CAN

I/O extension modules, see Q-modules: QAIO and QDIO

F«F-Bus» (front panel connector of the MSC II),
see fieldbus interface of the MSC II: «F-Bus»**Fieldbus interface of the MSC II** • 72

«F-Bus» (MSC II front panel connectors) • 77

Figures, list of • viii**Front panel**

DIN rail modules • 29

MSC II • 77

Front view

DIN rail modules • 29

MSC II • 77

G**Grounding**

CAN bus networks • 57

CAN bus termination resistor with signal grounding • 57, 58

grounding concept • 38

signal grounding of DIN rail modules • 38, 42

I**Identification of M3000® modules • 23****Incremental sensors**

- connecting to the MSC II • 105–107
- connection diagram of the MSC II with an incremental sensor • 105
- incremental encoder (frequency modulation negative logic) • 107
- incremental encoder (frequency modulation positive logic) • 107
- incremental encoder (pulse train negative logic) • 107
- incremental encoder (pulse train positive logic) • 106
- incremental encoder (standard) • 105
- terminal designations on sensors of various manufacturers • 105

Inputs of the MSC II, see I/Os of the MSC II**Insensitivity to corrosion**

- M3000® modules • 71
- MSC II • 75

Installation • 37

- safety instructions • 8, 31, 33, 35, 40, 43

Insulation resistance

- digital inputs of the MSC II • 97
- digital outputs of the MSC II • 99
- MSC II • 75

Interface cables

- CAN bus interface cables • 59
 - part numbers • 120
 - permissible cable lengths in CAN bus networks • 59
 - permissible stub cable lengths in CAN bus networks • 59
 - suitable cables • 60
- EtherCAT interface cables • 49
- Ethernet interface cables • 48
 - part numbers • 120
- Null Modem Cable • 54
- Profibus interface cables • 52
 - maximum cable lengths in Profibus networks • 53
 - permissible stub cable lengths in Profibus networks • 53
 - suitable cables • 53
- serial interface cables • 54

Interfaces of the MSC II • 72

- CAN bus interfaces, see CAN bus interfaces: MSC II
- E-bus interfaces, see E-bus interfaces: MSC II
- Ethernet interface,
 - see Ethernet: Ethernet interface of the MSC II
- fieldbus interface, see fieldbus interface of the MSC II
- sensor interfaces, digital,
 - see sensor interfaces of the MSC II, digital
- serial interfaces, see interfaces of the MSC II, serial
- terminal assignment • 78–81

Interfaces of the MSC II, serial • 111

- MACS interface • 111
 - «MACS» (MSC II front panel connector) • 77
- SIO interface • 111
 - «Rx» and «Tx» (LEDs for displaying receive/transmission activity) • 81
 - «SIO» (MSC II front panel connector) • 77
 - terminal assignment • 79

I/O extension modules, see Q-modules: QAIO and QDIO**«I/O1»...«I/O4», see LEDs of the MSC II****I/Os of the MSC II • 73**

- digital I/Os, see I/Os of the MSC II, digital
- 'Outputs Enabled' output • 111
 - «OutEN» (LED of the MSC II for displaying the states of all outputs and E-bus communication) • 82, 112
- safety instructions • 12, 111

I/Os of the MSC II, digital • 73, 93–99

- digital inputs • 97–99
 - basic wiring diagram • 97
 - disturbance suppression • 97
 - insulation resistance • 99
 - pulse detection • 97
 - specifications • 98
 - U/I working ranges • 99
- digital outputs • 95–97
 - basic wiring diagram • 95
 - insulation resistance • 97
 - load connection • 96
 - open collector outputs • 95
 - open emitter outputs • 95
 - overload protection • 95
 - specifications • 96
- «I/O1»...«I/O4» (LEDs of the MSC II for displaying the operational state of the digital I/Os) • 81, 93
- power supply • 93
- terminal assignment • 78

IP address of the MSC II • 84, 86**Item number, see part numbers****L****«L1+», see LEDs of the MSC II****LAN**

- LAN interface of the MSC II
 - terminal assignment of the «LAN» connector • 80

«LAN», see LEDs of the MSC II**«LCAN», see LEDs of the MSC II****«LED1»...«LED3», see LEDs of the MSC II****LEDs of the MSC II • 77, 81–82**

- «A1»...«A4» (wire fault display for digital sensor interfaces) • 82, 102
- «Aux1»...«Aux4» (activated by application program) • 81
- «B1»...«B4» (wire fault display for digital sensor interfaces) • 82, 102
- «EBus» (displays E-bus transmission activity) • 81
- «Error» (error display) • 82, 83
- «I/O1»...«I/O4» (display the operational state of the digital I/Os) • 81, 93
- «L1+» (displays the state of the power supply for the internal electronics) • 81
- «LCAN» (displays LocalCAN transmission activity) • 81, 109
- «LED1»...«LED3» (activated by application program or error display) • 82, 83
- «Link» (displays Ethernet link pulse and activity) • 82
- «OutEN» (displays the states of all outputs and E-bus communication) • 82
- «Rx» and «Tx» (displays receive/transmission activity of the SIO interface) • 81
- «Speed» (displays Ethernet connection speed) • 82
- «TRM» (indicates that the LocalCAN interface's termination resistor is switched on) • 81, 110
- «Tx» and «Rx» (displays receive/transmission activity of the SIO interface) • 81
- «WCAN» (displays WideCAN transmission activity) • 81, 109
- «Z1»...«Z4» (wire fault display for digital sensor interfaces) • 82, 102

Liability

- exclusion of liability • 3
- exclusion of liability for this manual • 1

License key of the MSC II • 24, 85–86
 attachment screws • 86
 features provided by the various license keys • 118
 license key slot «LK» • 77, 87
 mounting • 87
 required tool • 86
 part numbers • 118
 removing • 87
 required tool • 86
 run-time license • 85
 safety instructions • 11, 85, 86, 87

«Link», see LEDs of the MSC II

List of figures • viii

List of tables • vi

«LK» (on the front panel of the MSC II),
 see license key of the MSC II: license key slot «LK»

Load connection of digital outputs • 96

LocalCAN • 14
 LocalCAN bus groups • 66
 LocalCAN bus interface of the MSC II • 56, 64, 109
 make LocalCAN bus available over QEBUS-CAN • 19

Locating pin
 DIN rail modules • 29
 MSC II • 77

Locking slide
 DIN rail modules • 29
 MSC II • 77

M

M_WATCHDOG, see watchdog of the MSC II

M3000®
 M3000® modules, see M3000® modules
 network topology with CAN bus • 14
 system architecture • 14
 system overview • 13

M3000® modules
 DIN rail modules, see DIN rail modules
 identification • 23
 I/O extension modules, see Q-modules: QAIO and QDIO
 MSC II, see MSC II
 networking • 64–68
 QAIO 16/4, see Q-modules: QAIO 16/4
 QDIO, see Q-modules: QDIO
 QEBUS-CAN, see Q-modules: QEBUS-CAN
 Q-modules, see Q-modules
 RDIO, see R-modules: RDIO
 RDISP, see R-modules: RDISP
 remote modules, see R-modules
 R-modules, see R-modules

M3000® modules • 16–21

M3000® Starter Kits • 114

MACS • 25
 communication between MSC II and MACS • 84
 communication parameters
 Ethernet interface • 84
 configuration of the MSC II • 84
 MACS HMI (visualization package) • 26, 119
 part number • 119
 programming languages • 25
 programming the MSC II • 84
 scope of functionality • 25
 software maintenance contract • 119

MACS HMI, see MACS: MACS HMI

Maintenance • 70
 safety instructions • 9, 69

Maintenance contract for MACS,
 see MACS: software maintenance contract

Manual, see user manual M3000® and MSC II

Maximum admissible current for the power supply terminals of M3000® modules • 43

Memory of the MSC II • 73

Module width of an M3000® module, see dimensions

Moog Authentic Repairs, see repair: Moog Authentic Repairs

Moog Authentic Repair seal, see repair: repair seal

Mounting
 DIN rail modules on DIN top-hat rails • 33
 license key of the MSC II • 87
 required tool • 86

MSC I • 16

MSC II • 17, 72–113
 as master of E-bus groups • 61
 dimensions • 73, 74
 environmental conditions for operation • 75
 climatic conditions • 75
 electrical conditions and requirements • 75
 mechanical conditions and requirements • 75
 front panel • 77
 front view • 77
 part numbers • 115
 view of the module • 77

MSC II Starter Kit • 15

MSD Motion Controller • 22
 part numbers • 115

MSD Servodrive • 23

N

Nameplate
 M3000® modules • 23
 MSC II • 113

Networking M3000® modules
 CAN bus networks, see CAN bus networks
 Ethernet networks, see Ethernet: networks
 networking DIN rail modules,
 see DIN rail modules: networking

Network nodes, see CAN bus network stations

Networks
 CAN bus networks, see CAN bus networks
 Ethernet networks, see Ethernet: networks
 networking DIN rail modules,
 see DIN rail modules: networking
 Profibus networks, see Profibus

O

Open collector output of the MSC II,
 see I/Os of the MSC II, digital: digital outputs

Open emitter output of the MSC II,
 see I/Os of the MSC II, digital: digital outputs

Operating elevation • 75

Operating instructions, see user manual M3000® and MSC II

Order number, see part numbers

Original packaging is to be retained! • 3

Oscillations, permissible for MSC II • 75

«OutEN», see LEDs of the MSC II

'Outputs Enabled',
 see I/Os of the MSC II: 'Outputs Enabled' output

Outputs of the MSC II, see I/Os of the MSC II

Overall width of an M3000® module, see dimensions

Overload protection of digital outputs • 95

P**Packaging**

Original packaging is to be retained! • 3

Part number

MSC II Starter Kit • 114

MSD Motion Controller Starter Kit • 114

Part numbers

CAN bus accessories • 120

CAN bus termination resistors • 120

interface cables • 120

license key of the MSC II • 118

M3000® Starter Kits • 114

MSC II • 115

MSD Motion Controller • 115

plug-in terminal strips for DIN rail modules • 121

power supply device • 117

Q-modules • 116

R-modules • 117

software

MACS • 119

software for R-modules • 119

software maintenance contract • 119

training programs • 123

Peer-to-peer connection of 2 network stations

(Ethernet) • 47

Performance characteristics of the MSC II • 73

interfaces, see interfaces of the MSC II

I/Os, see I/Os of the MSC II

'Outputs Enabled' output,

see I/Os of the MSC II: 'Outputs Enabled' output

watchdog, see watchdog of the MSC II

Personnel, selection and qualification

only qualified users may work with and on M3000®! • 2

Pin assignment, see terminal assignment**Place of storage for manuals • 1****Plug assignment, see terminal assignment****Plug-in terminal strips for DIN rail modules**

connection methods • 46

connectors for plug-in terminal strips

front view of the DIN rail module • 29

«X2», «X4», «X6», «X7», «X9», «X10» connectors of the MSC II • 77

part numbers • 121

required number • 122

side view of DIN rail modules with plug-in terminal strips • 29

spring loaded terminals • 46

Potential equalization in CAN bus networks,

see CAN bus networks: potential equalization

Power consumption by DIN rail modules • 40**Power supply • 39–45**

characteristics • 39

connecting M3000® modules • 41

digital I/Os of the MSC II • 93

maximum admissible current • 43

MSC II • 75, 89–90

«L1+» (LED for displaying the state of the power supply for the internal electronics) • 81

power supply device

part number • 117

rated voltage • 39

safety extra-low voltage SELV • 39

sensors • 43–45

switching on/off the power supply

behavior of the MSC II • 89

terminal assignment • 78

Processor of the MSC II • 73**Product range • 114–123****Profibus • 50–53**

9 pole D-sub connector • 52

connector with internal longitudinal inductivity • 52

connector with switchable termination • 52

maximum cable lengths • 53

modules with Profibus DP interface • 50

number of network stations • 51

permissible stub cable lengths • 53

Profibus interface of the MSC II

terminal assignment of the «F-Bus» connector • 79

suitable cables • 53

topology • 51

wiring • 50

Profibus DP interface

MSC II • 100

Programming languages in MACS • 25**Programming the MSC II • 84****Project planning • 37**

safety instructions • 8, 40, 43

Proper operation, see proper use**Proper use • 2**

safety related systems • 2

Protection class of the MSC II • 75**Pulse detection of digital inputs • 97****Q****QAIO 16/4, see Q-modules: QAIO 16/4****Q-connector**

40 pole connector of the E-bus interface • 60

front and side views of DIN rail modules • 29

front view of the MSC II • 77

QDIO, see Q-modules: QDIO**QEBUS-CAN, see Q-modules: QEBUS-CAN****Q-modules • 17**

part numbers • 116

power consumption • 40

QAIO 16/4 • 18

QDIO • 18

QEBUS-CAN • 19

Qualified users, see personnel, selection and qualification**R****Rated voltage of the power supply • 39****RDIO, see R-modules: RDIO****RDISP, see R-modules: RDISP****Rebooting the MSC II, see resetting the MSC II****Release date of this manual • 1****Remote modules, see R-modules****Removing**

DIN rail modules from the DIN top-hat rail • 36

license key of the MSC II • 87

required tool • 86

Repair • 70

Moog Authentic Repairs • 70

repair seal • 70

safety instructions • 9, 69

Reproduction prohibition for this manual • A**Reservation of changes for this manual • A, 1****Reset button of the MSC II • 77, 88**

safety instructions • 12, 88

Resetting the MSC II • 88

reset button, see reset button of the MSC II

safety instructions • 12, 89

Restarting the MSC II, see resetting the MSC II

Retain the original packaging! • 3
Reverse energization is to be avoided! • 40, 43, 45, 93
R-modules • 19
 part numbers • 117
 power consumption • 40
 RDIO • 20
 as master of E-bus groups • 61
 RDISP • 20
 software for R-modules
 CPRDISP • 20, 119
 part numbers • 119
RT-ETH
 RT-ETH interface of the MSC II
 terminal assignment of the «RT-ETH1» connector • 81
 terminal assignment of the «RT-ETH2» connector • 81
Run-time license of the MSC II (in license key) • 85
 «Rx», see LEDs of the MSC II

S

Safety extra-low voltage SELV • 39
Safety instructions
 arrangement of DIN rail modules • 31
 cleaning • 9, 69
 communication between MSC II and MACS • 11, 84
 environmental conditions • 7, 27, 74
 ESD • 7
 installation • 8, 31, 33, 35, 40, 43
 license key of the MSC II • 11, 85, 86, 87
 maintenance • 9, 69
 mounting
 DIN rail modules • 33
 license key of the MSC II • 86
 'Outputs Enabled' output of the MSC II • 12, 111
 project planning • 8, 40, 43
 removing
 DIN rail modules • 35
 license key of the MSC II • 87
 repair • 9, 69
 reset button of the MSC II • 12, 88
 resetting the MSC II • 12, 89
 safety related systems • 2, 6
 service • 9, 69
 shutdown • 9, 69
 storing M3000® modules • 10, 71
 transporting M3000® modules • 10, 71
 typographical conventions • 6, 124
 update rate of E-bus messages • 62
Safety related systems • 2
 safety instructions • 2, 6
SELV, see safety extra-low voltage SELV
Sensor interfaces of the MSC II, digital • 101–107
 connecting incremental sensors • 105–107
 connecting SSI sensors • 102–104
 connection diagram
 MSC II in master mode • 103
 MSC II in slave mode • 104
 terminal assignment • 79, 80
 wire fault monitoring • 102
 wire fault display LEDs • 82, 102
Sensor interfaces of the MSC II, termination resistors • 101

Sensors
 connecting incremental sensors to the MSC II • 105–107
 termination resistors • 101
 wire fault monitoring • 102
 connecting signal cables over plug-in terminal strips • 46
 connecting SSI sensors to the MSC II • 102–104
 termination resistors • 101
 wire fault monitoring • 102
 connecting to the power supply • 43–45
 incremental encoder (frequency modulation negative logic) • 107
 incremental encoder (frequency modulation positive logic) • 107
 incremental encoder (pulse train negative logic) • 107
 incremental encoder (pulse train positive logic) • 106
 incremental encoder (standard) • 105
Service
 cleaning, see cleaning
 maintenance, see maintenance
 repair, see repair
 safety instructions • 9, 69
 servicing, see maintenance
Servicing, see maintenance
Shock, permissible for MSC II • 75
Shutdown
 safety instructions • 9, 69
Signal cables
 connection over plug-in terminal strips • 46
 connection to MSC II • 32
Signal grounding
 CAN bus termination resistor with signal grounding,
 see grounding: CAN bus termination resistor with signal
 grounding
 DIN rail modules,
 see grounding: signal grounding of DIN rail modules
«SIO» (front panel connector of the MSC II),
 see interfaces of the MSC II, serial: SIO interface
SIO interface of the MSC II,
 see interfaces of the MSC II, serial: SIO interface
Software
 copyright • 5
 development environment MACS, see MACS
 MACS, see MACS
 software for R-modules,
 see R-modules: software for R-modules
Software maintenance contract for MACS,
 see MACS: software maintenance contract
Spring loaded terminals,
 see plug-in terminal strips for DIN rail modules
SSI sensor
 connecting to the MSC II • 102–104
 connection diagram
 MSC II in master mode • 103
 MSC II in slave mode • 104
SSI sensor start time • 91
Standards
 overview of quoted standards • 127–129
Starter kit, see MSC II
 starter kit
Storing M3000® modules
 environmental conditions • 71
 air pressure, permissible • 71
 ambient temperature, permissible • 71
 contamination level • 71, 75
 insensitivity to corrosion • 71, 75
 relative air humidity, permissible • 71
 safety instructions • 10, 71
Storing manuals
 place of storage • 1

Symbols and styles used in this manual,

see typographical conventions

System, see M3000®

System architecture, see M3000®: system architecture

System overview, see M3000®: system overview

T

Table of Contents • i

Tables, list of • vi

Task reaction time • 92

Terminal assignment

M3000® modules • 23

MSC II • 78–81

Termination resistors, see CAN bus termination resistors

TIA/EIA * interface cable**,

see interface cables: serial interface cables

Timing diagram • 91

Top-hat rail, see DIN top-hat rail TH 35-7.5

Trademarks • 5

Training programs, part numbers • 123

Transporting M3000® modules

environmental conditions • 71

air pressure, permissible • 71

ambient temperature, permissible • 71

contamination level • 71, 75

insensitivity to corrosion • 71, 75

relative air humidity, permissible • 71

safety instructions • 10, 71

«TRM», see LEDs of the MSC II

«Tx», see LEDs of the MSC II

Type plate, see nameplate

Typographical conventions • 124

U

U/I working ranges of digital inputs • 99

USB

USB interface of the MSC II

terminal assignment of the «USB1» connector • 80

terminal assignment of the «USB2» connector • 80

User manual M3000® and MSC II

abbreviations used, see abbreviations used

copyright • A

date of release • 1

duplication prohibition • A

exclusion of liability • 1

place of storage • 1

reproduction prohibition • A

reservation of changes • A, 1

styles and symbols used, see typographical conventions

typographical conventions, see typographical conventions

version number • 1

Users, qualified, see personnel, selection and qualification

V

Version number of this manual • 1

View of the module

DIN rail modules • 29

MSC II • 77

Visualization package, see MACS: MACS HMI

W

Warranty

exclusion of warranty • 3

Watchdog of the MSC II • 111

«WCAN» (front panel connectors of the MSC II),

see CAN bus interfaces: MSC II

«WCAN» (LED), see LEDs of the MSC II

Weight of the MSC II • 73

WideCAN • 14

WideCAN bus groups • 67

WideCAN bus interface of the MSC II • 56, 64, 109

terminal assignment of the «WCAN» connectors • 78

Wire fault display LEDs of the MSC II

«A1», «B1», «Z1»...«A4», «B4», «Z4» (wire fault display LEDs for digital sensor interfaces) • 82, 102

Wire fault monitoring

sensor interfaces, digital • 102

wire fault display LEDs • 82, 102

Wiring of CAN bus networks • 57

X

«X2», «X4», «X6», «X7», «X9», «X10» (Plug-in terminal strip connectors of the MSC II)

front view of the MSC II with plug-in terminal-strip connectors • 77

Z

«Z1»...«Z4», see LEDs of the MSC II

MOOG.COM/INDUSTRIAL

For the location nearest you, contact
moog.com/industrial/globallocator

Argentina	+54	11 4326 5916	info.argentina@moog.com
Australia	+61	3 9561 6044	info.australia@moog.com
Austria	+43	664 144 65 80	info.austria@moog.com
Brazil	+55	11 5523 8011	info.brazil@moog.com
China	+86	21 2893 1600	info.china@moog.com
Finland	+358	9 2517 2730	info.finland@moog.com
France	+33	1 4560 7000	info.france@moog.com
Germany	+49	7031 622 0	info.germany@moog.com
Hong Kong	+852	2 635 3200	info.hongkong@moog.com
India	+91	80 4120 8799	info.india@moog.com
Ireland	+353	21 451 9000	info.ireland@moog.com
Italy	+39	0332 421 111	info.italy@moog.com
Japan	+81	463 55 3615	info.japan@moog.com
Korea	+82	31 764 6711	info.korea@moog.com
Luxembourg	+352	40 46 401	info.luxembourg@moog.com
Netherlands	+31	252 462 000	info.netherlands@moog.com
Norway	+47	64 94 19 48	info.norway@moog.com
Russia	+7	31713 1811	info.russia@moog.com
Singapore	+65	6773 6238	info.singapore@moog.com
South Africa	+27	12 653 6768	info.southafrica@moog.com
Spain	+34	902 133 240	info.spain@moog.com
Sweden	+46	31 680 060	info.sweden@moog.com
Switzerland	+41	71 394 5010	info.switzerland@moog.com
United Kingdom	+44	1684 296600	info.unitedkingdom@moog.com
USA	+1	716 652 2000	info.usa@moog.com

© Moog GmbH

User Manual M3000® and MSC II
CA65865-001; Version 1.1, 08/08

All rights reserved.
Subject to change without notice.