

STANDARD ELECTRIC LINEAR SERVOACTUATION PACKAGES

SIZE 3, 4 AND 5

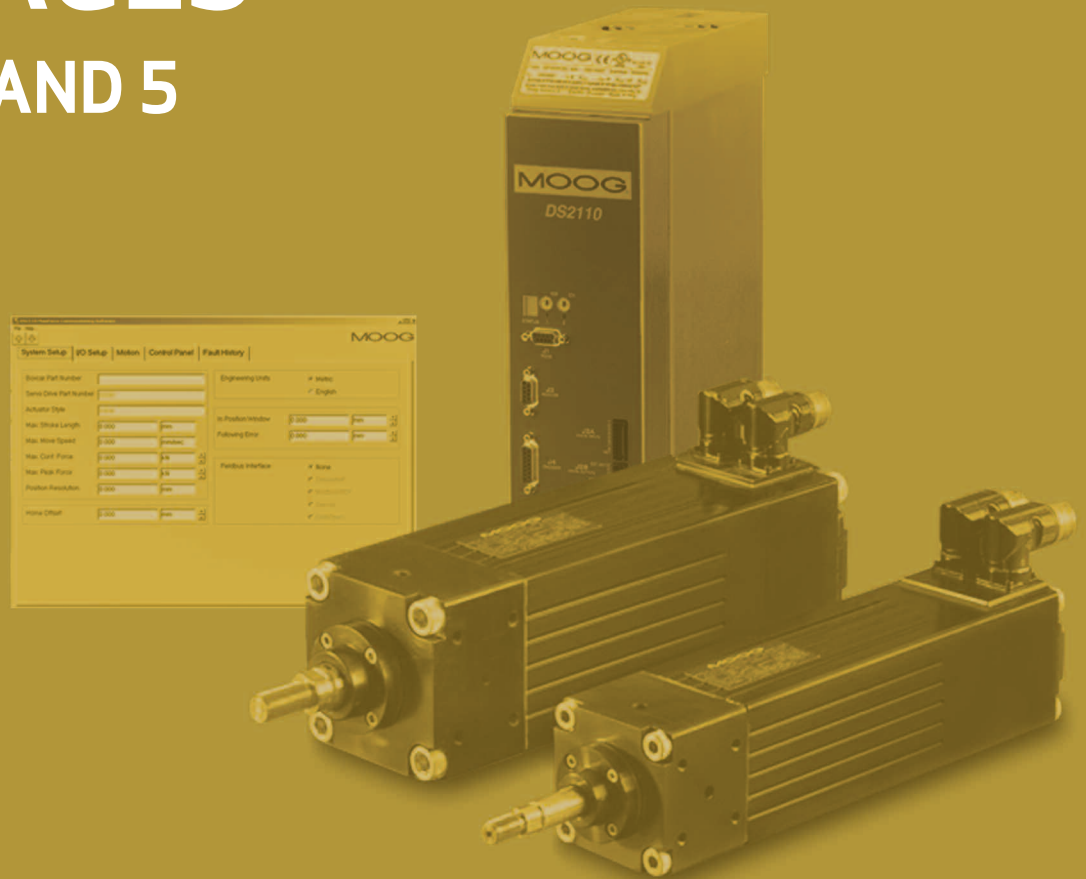

Rev. A 0709

HIGH PERFORMANCE DESIGN INCREASES
MACHINE PRODUCTIVITY; INTEGRATED SYSTEM
INCREASES EASE OF INSTALLATION

Whenever the highest levels of motion control performance and design flexibility are required, you'll find Moog expertise at work. Through collaboration, creativity and world-class technological solutions, we help you overcome your toughest engineering obstacles. Enhance your products' performance. And help take your thinking further than you ever thought possible.

PRODUCT OVERVIEW	3
SIZE 3	
PERFORMANCE SPECIFICATIONS	4
PERFORMANCE CURVES	5
SIZE 4	
PERFORMANCE SPECIFICATIONS	6
PERFORMANCE CURVES	7
SIZE 5	
PERFORMANCE SPECIFICATIONS	8
PERFORMANCE CURVES	9
INSTALLATION DRAWINGS	
SERVOACTUATOR	10
ROD END KITS	11
ELECTRICAL SCHEMATIC	12
ORDERING INFORMATION	13
SERVODRIVE DS2110	
TECHNICAL DATA	14
ORDERING INFORMATION	14
CONNECTIONS AND DIMENSIONS	15



This catalog is for users with technical knowledge. To ensure that all necessary characteristics for function and safety of the system are given, the user has to check the suitability of the products described herein. The products described herein are subject to change without notice. In case of doubt, please contact Moog.

For the most current information, visit www.moog.com/servomotorsanddrives

Moog is a registered trademark of Moog Inc. and its subsidiaries. All trademarks as indicated herein are the property of Moog Inc. and its subsidiaries.

©Moog Inc. 2009. All rights reserved. All changes are reserved.

An Integrated System Designed For Maximum Machine Performance

Moog Standard Electric Linear Servoactuation Packages provide an electric alternative to traditional hydraulic actuation. Combining an electric linear servoactuator, a servodrive and integrated software, this high performance solution delivers world-class motion control to a wide array of linear applications, ensuring high speed and high force in today’s most demanding industrial environments.

Advanced Ball Screw Design

- Higher efficiency results in increased continuous force rating as well as reduced energy consumption
- Higher dynamic load capacity provides up to 2x the life of competing technologies

Quick Start-Up

- Simple mounting means lower installation times
- Automatic configuration of actuator through intelligent drive

Optimized to work together

The Electric Linear Servoactuation Packages are solutions that employ Moog’s innovative, state-of-the-art servodrive and user-friendly commissioning software tailored for our Servoactuators. All of the products are optimized to work together to provide the highest level of performance and accuracy.

Engineered in advance

Moog’s depth of motion control expertise provides you with a solution unique to your machine needs. The majority of the work has been engineered in advance so that with minimal effort the system can be easily implemented in your application.

World-class components for high performance

The Electric Linear Servoactuation Package solution features genuine Moog products so you can rest assured that you’re getting the world-class performance today’s design engineers have come to trust.

User-friendly software

Moog’s intuitive commissioning software saves time at start up by automatically uploading preset system tuning parameters off the absolute encoder. The software reduces errors by implementing preset safety limits for speed, force and stroke length. In addition, the encoder file provides the drive with data on actuator speed, force, and position, eliminating the need for the user to convert, then program motor speed, motor current, and encoder counts into these values.

There is also a Control Panel function and Fault History which allows ease of setup and troubleshooting. Various levels of intelligence and communication options are available.

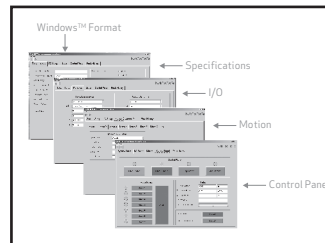

PERFORMANCE SPECIFICATIONS FOR TYPICAL MODELS

Frame	Lead Lengths mm (in)	Continuous Stall Force kN (in/sec)	Peak Stall Force kN (lbs)	Stroke Lengths mm (in)	Brake Holding Force (optional) kN (lbs)	Maximum Speed mm/sec in/sec
Size 3	5 (0.197)	4.31 (970)	14.60 (3,282)	150 (5.9)	4.99 (1,122)	321 (12.6)
	10 (0.394)	2.16 (485)	7.30 (1,641)	300 (11.8)	2.49 (561)	641 (25.2)
Size 4	5 (0.197)	8.77 (1,971)	22.17 (4,985)	150 (5.9)	16.08 (3,614)	205 (8.1)
	10 (0.394)	4.38 (986)	11.09 (2,493)	300 (11.8)	8.04 (1,807)	410 (16.2)
Size 5	5 (0.197)	27.76 (6,242)	72.25 (16,243)	150 (5.9)	33.26 (7,478)	146 (5.7)
	10 (0.394)	13.88 (3,121)	36.13 (8,122)	300 (11.8)	16.63 (3,739)	291 (11.5)

SIZE 3

SERVOMOTOR PERFORMANCE LOW VOLTAGE

Servomotor Stack Number	Brake Inertia kg*cm ² (lbf*in*s ²)	Continuous Stall Torque Nm (inf-lb)	Peak Stall Torque Nm (inf-lb)	Nominal Speed RPM	Brake Holding Torque Nm (inf-lb)	Brake Coil Power (24 VDC Coil) Watts	Continuous Current Arms	Peak Current Arms
-8	0.18 (0.00016)	3.87 (34.3)	13.22 (117.0)	3,900	4.50 (39.8)	12	4.2	17

SERVOMOTOR PERFORMANCE HIGH VOLTAGE

Servomotor Stack Number	Brake Inertia kg*cm ² (lbf*in*s ²)	Continuous Stall Torque Nm (inf-lb)	Peak Stall Torque Nm (inf-lb)	Nominal Speed RPM	Brake Holding Torque Nm (inf-lb)	Brake Coil Power (24 VDC Coil) Watts	Continuous Current Arms	Peak Current Arms
-8	0.18 (0.00016)	3.99 (35.3)	13.40 (118.6)	3,900	4.50 (39.8)	12	3.0	10.3

SERVOACTUATOR PERFORMANCE

Nominal backlash	mm (in)	0.005 (0.00197)
Maximum backlash	mm (in)	0.12 (0.00394)
Lead accuracy (class 5)	mm/300mm (in/ft)	0.023 (0.000906)
Electrical resolution	mm (in)	0.00031 (0.0000122)
Maximum static load	kN (lb)	23 (5170.86)
Screw pitch diameter	mm (in)	20.8 (0.82)
Environmental rating		IP67
Actuator inertia	150mm kg*cm ² (lbf*in*s ²)	2.1584 (0.00191)
	300mm kg*cm ² (lbf*in*s ²)	2.8928 (0.00256)
Standard strokes	mm (in)	150, 300 (5.9, 11.8)
Maximum radial misalignment		0.1
Actuator mass adder / unit stroke	kg/mm (lb/in)	0.0353 (1.977)

SERVOACTUATOR PERFORMANCE LOW VOLTAGE

Servomotor Stack Number	Servoactuator Base Mass kg (lb)	Screw Lead mm	Continuous Stall Force kN (lbf)	Peak Stall Force kN (lbf)	Brake Holding Force kN (lbf)	Maximum Speed mm/sec (in/sec)	Maximum Linear Inertia kg (lb)	Dynamic Load Rating kN (lbf)
-8	6.1 (13.4)	5	4.18 (941)	14.41 (3,239)	4.99 (1,122)	321 (12.6)	3,408 (7,498)	32.5 (7,307)
		10	2.09 (470)	7.20 (1,619)	2.49 (561)	641 (25.2)	852 (1,875)	23.4 (5,261)

SERVOACTUATOR PERFORMANCE HIGH VOLTAGE

Servomotor Stack Number	Servoactuator Base Mass kg (lb)	Screw Lead mm	Continuous Stall Force kN (lbf)	Peak Stall Force kN (lbf)	Brake Holding Force kN (lbf)	Maximum Speed mm/sec (in/sec)	Maximum Linear Inertia kg (lb)	Dynamic Load Rating kN (lbf)
-8	6.1 (13.4)	5	4.31 (970)	14.60 (3,282)	4.99 (1,122)	321 (12.6)	3,408 (7,498)	32.5 (7,307)
		10	2.16 (485)	7.30 (1,641)	2.49 (561)	641 (25.2)	852 (1,875)	23.4 (5,261)

DEFINITIONS

Continuous Stall Force:

Force produced by the servoactuator at the continuous servomotor torque and at zero speed. Continuous force declines as servomotor speed increases. Consult performance curves for force rating at higher speeds. Continuous servomotor torque is limited by temperature and thus, the continuous force will be reduced with ambient temperatures above 25°C (77°F).

Peak Stall Force: Force produced by the servoactuator at the peak servomotor torque and at zero speed. Peak force declines as servomotor speed increases. Consult performance curves for force rating at higher speeds. Peak force can be held only for short durations (typically less than 1 minute) after which a cool down period at less than the continuous rating is required.

Brake Holding Force: Maximum force that the optional brake will hold stationary. Brake should not be used to stop a moving servoactuator as damage to the brake will result.

Maximum Static Load: Mechanical load limit of the servoactuator components. This is a limitation of the structural components of the servoactuator.

Dynamic Load Rating: The load at which the estimated life of a ballscrew or bearing will be 1 million revolutions

Maximum Speed: The maximum linear speed for the servoactuator. The available force at maximum speed is significantly less than the Stall Forces. Consult the Performance curves for Force/Speed relationship.

Accuracy: The ability of a positioning system to move exactly to a commanded position.

Repeatability: The ability of a positioning system to return to the same point from the same direction with the same load.

Resolution: The smallest positioning increment possible.

Lead Accuracy: The maximum deviation from nominal lead over specified interval.

Maximum Linear Inertia: This is the maximum load mass that can be connected to the servoactuator. This mass results in 10:1 inertia match to servomotor with 180 mm stroke. Increasing stroke length will reduce this value while reducing stroke will increase this value. For exact inertia matching, refer to EMA sizing software.

Servoactuator Base Mass: This is the mass of the servoactuator with 0° stroke. To get total servoactuator mass multiply stroke X servoactuator mass adder and add to servoactuator base mass.

SIZE 3

LOW VOLTAGE

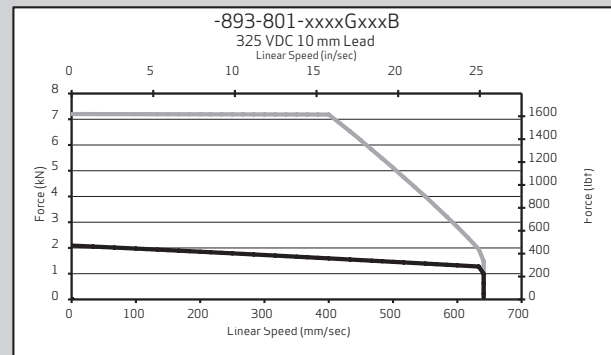
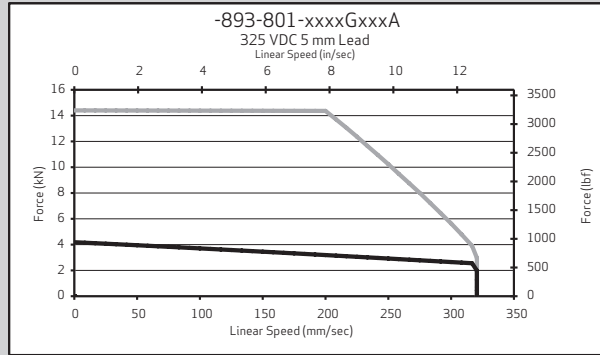

HIGH VOLTAGE

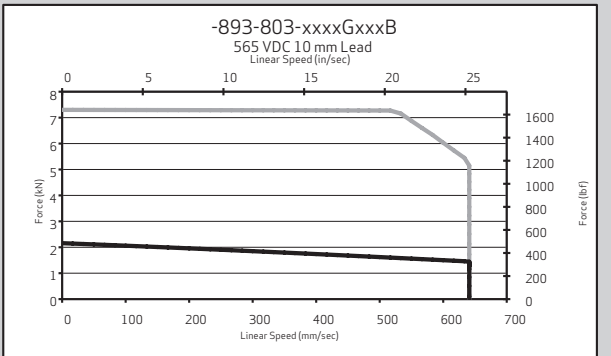
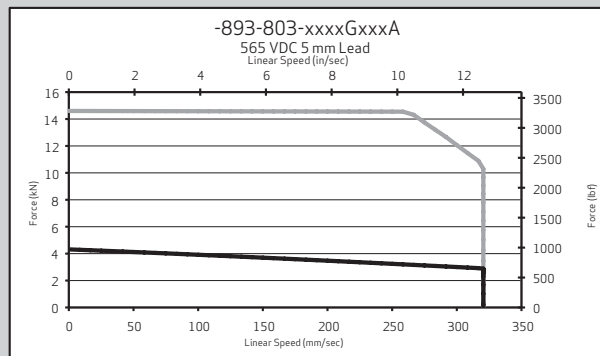

Continuous Force
 Peak Force

SIZE 4

SERVOMOTOR PERFORMANCE LOW VOLTAGE

Servomotor Stack Number	Brake Inertia kg*cm ² (lbf*in*s ²)	Continuous Stall Torque Nm (inf-lb)	Peak Stall Torque Nm (inf-lb)	Nominal Speed RPM	Brake Holding Torque Nm (inf-lb)	Brake Coil Power (24 VDC Coil) Watts	Continuous Current Arms	Peak Current Arms
-8	1.00 (0.00089)	8.09 (71.6)	22.01 (194.8)	3,500	14.50 (128.3)	15.6	9.2	28

SERVOMOTOR PERFORMANCE HIGH VOLTAGE

Servomotor Stack Number	Brake Inertia kg*cm ² (lbf*in*s ²)	Continuous Stall Torque Nm (inf-lb)	Peak Stall Torque Nm (inf-lb)	Nominal Speed RPM	Brake Holding Torque Nm (inf-lb)	Brake Coil Power (24 VDC Coil) Watts	Continuous Current Arms	Peak Current Arms
-8	1.00 (0.00089)	8.07 (71.4)	20.33 (179.9)	3,300	14.50 (128.3)	15.6	5.8	18.5

SERVOACTUATOR PERFORMANCE

Nominal backlash	mm (in)	0.005 (0.00197)
Maximum backlash	mm (in)	0.12 (0.00394)
Lead accuracy (class 5)	mm/300mm (in/ft)	0.023 (0.000906)
Electrical resolution	mm (in)	0.00031 (0.0000122)
Maximum static load	kN (lb)	41 (9217.63)
Screw pitch diameter	mm (in)	32.5 (1.28)
Environmental rating		IP67
Actuator inertia	150mm kg*cm ² (lbf*in*s ²)	9.2995 (0.00823)
	300mm kg*cm ² (lbf*in*s ²)	13.051 (0.0116)
Standard strokes	mm (in)	150, 300 (5.9, 11.8)
Maximum radial misalignment		0.1
Actuator mass adder / unit stroke	kg/mm (lb/in)	0.0353 (1.977)

SERVOACTUATOR PERFORMANCE LOW VOLTAGE

Servomotor Stack Number	Servoactuator Base Mass kg (lb)	Screw Lead mm	Continuous Stall Force kN (lbf)	Peak Stall Force kN (lbf)	Brake Holding Force kN (lbf)	Maximum Speed mm/sec (in/sec)	Maximum Linear Inertia kg (lb)	Dynamic Load Rating kN (lbf)
-8	6.9 (15.2)	5	8.79 (1,977)	24.01 (5,398)	16.08 (3,614)	205 (8.1)	14,685 (32,307)	46.2 (10,387)
		10	4.40 (989)	12.00 (2,699)	8.04 (1,807)	410 (16.2)	3,671 (8,077)	32.1 (7,217)

SERVOACTUATOR PERFORMANCE HIGH VOLTAGE

Servomotor Stack Number	Servoactuator Base Mass kg (lb)	Screw Lead mm	Continuous Stall Force kN (lbf)	Peak Stall Force kN (lbf)	Brake Holding Force kN (lbf)	Maximum Speed mm/sec (in/sec)	Maximum Linear Inertia kg (lb)	Dynamic Load Rating kN (lbf)
-8	6.9 (15.2)	5	8.77 (1,971)	22.17 (4,985)	16.08 (3,614)	205 (8.1)	14685 (32,307)	46.2 (10,387)
		10	4.38 (986)	11.09 (2,493)	8.04 (1,807)	410 (16.2)	3671 (8,077)	32.1 (7,217)

DEFINITIONS

Continuous Stall Force:

Force produced by the servoactuator at the continuous servomotor torque and at zero speed. Continuous force declines as servomotor speed increases. Consult performance curves for force rating at higher speeds. Continuous servomotor torque is limited by temperature and thus, the continuous force will be reduced with ambient temperatures above 25°C (77°F).

Peak Stall Force: Force produced by the servoactuator at the peak servomotor torque and at zero speed. Peak force declines as servomotor speed increases. Consult performance curves for force rating at higher speeds. Peak force can be held only for short durations (typically less than 1 minute) after which a cool down period at less than the continuous rating is required.

Brake Holding Force: Maximum force that the optional brake will hold stationary. Brake should not be used to stop a moving servoactuator as damage to the brake will result.

Maximum Static Load: Mechanical load limit of the servoactuator components. This is a limitation of the structural components of the servoactuator.

Dynamic Load Rating: The load at which the estimated life of a ballscrew or bearing will be 1 million revolutions

Maximum Speed: The maximum linear speed for the servoactuator. The available force at maximum speed is significantly less than the Stall Forces. Consult the Performance curves for Force/Speed relationship.

Accuracy: The ability of a positioning system to move exactly to a commanded position.

Repeatability: The ability of a positioning system to return to the same point from the same direction with the same load.

Resolution: The smallest positioning increment possible.

Lead Accuracy: The maximum deviation from nominal lead over specified interval.

Maximum Linear Inertia: This is the maximum load mass that can be connected to the servoactuator. This mass results in 10:1 inertia match to servomotor with 180 mm stroke. Increasing stroke length will reduce this value while reducing stroke will increase this value. For exact inertia matching, refer to EMA sizing software.

Servoactuator Base Mass: This is the mass of the servoactuator with 0" stroke. To get total servoactuator mass multiply stroke X servoactuator mass adder and add to servoactuator base mass.

SIZE 4

LOW VOLTAGE

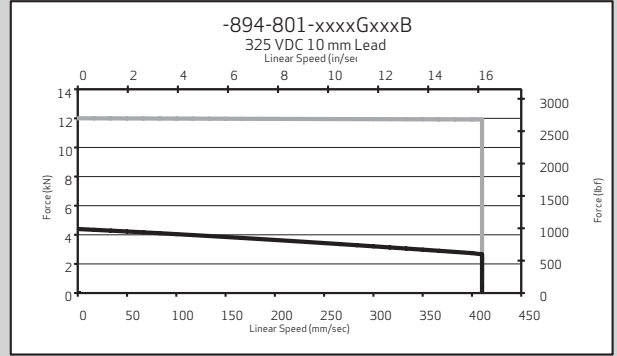
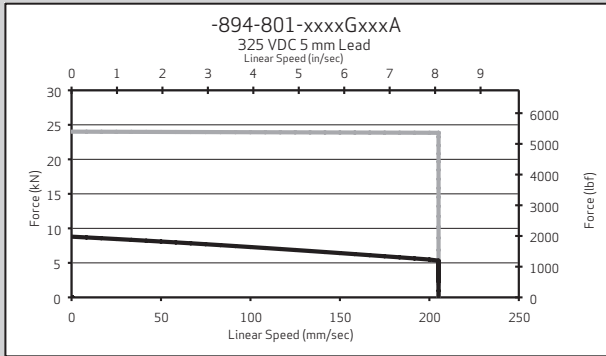

HIGH VOLTAGE

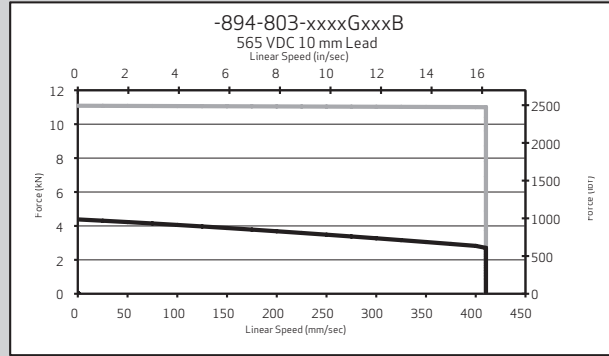
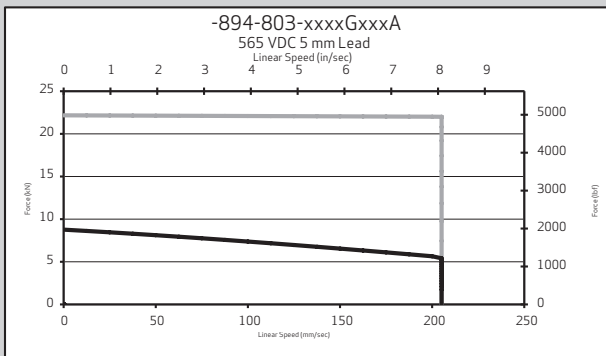

Continuous Force 
Peak Force 

SIZE 5

SERVOMOTOR PERFORMANCE LOW VOLTAGE

Servomotor Stack Number	Brake Inertia kg*cm ² (lbf*in*s ²)	Continuous Stall Torque Nm (inf-lb)	Peak Stall Torque Nm (inf-lb)	Nominal Speed RPM	Brake Holding Torque Nm (inf-lb)	Brake Coil Power (24 VDC Coil) Watts	Continuous Current Arms	Peak Current Arms
-8	4.90 (0.00434)	26.16 (231.6)	61.18 (541.5)	2,200	30.00 (265.5)	17	14.8	43

SERVOMOTOR PERFORMANCE HIGH VOLTAGE

Servomotor Stack Number	Brake Inertia kg*cm ² (lbf*in*s ²)	Continuous Stall Torque Nm (inf-lb)	Peak Stall Torque Nm (inf-lb)	Nominal Speed RPM	Brake Holding Torque Nm (inf-lb)	Brake Coil Power (24 VDC Coil) Watts	Continuous Current Arms	Peak Current Arms
-8	4.90 (0.00434)	25.44 (225.2)	66.13 (585.3)	2,800	30.00 (265.5)	17	15	43

SERVOACTUATOR PERFORMANCE

Nominal backlash	mm (in)	0.005 (0.00197)
Maximum backlash	mm (in)	0.12 (0.00394)
Lead accuracy (class 5)	mm/300mm (in/ft)	0.023 (0.000906)
Electrical resolution	mm (in)	0.00031 (0.0000122)
Maximum static load	kN (lb)	80 (17986)
Screw pitch diameter	mm (in)	45.75 (1.80)
Environmental rating		IP67
Actuator inertia	150mm kg*cm ² (lbf*in*s ²)	43.2994 (0.0383)
	300mm kg*cm ² (lbf*in*s ²)	59.899 (0.053)
Standard strokes	mm (in)	180, 300 (7.0, 11.8)
Maximum radial misalignment		0.1
Actuator mass adder / unit stroke	kg/mm (lb/in)	0.0353 (1.977)

SERVOACTUATOR PERFORMANCE LOW VOLTAGE

Servomotor Stack Number	Servoactuator Base Mass kg (lb)	Screw Lead mm	Continuous Stall Force kN (lbf)	Peak Stall Force kN (lbf)	Brake Holding Force kN (lbf)	Maximum Speed mm/sec (in/sec)	Maximum Linear Inertia kg (lb)	Dynamic Load Rating kN (lbf)
-8	21.5 (47.3)	5	28.56 (6,420)	66.84 (15,026)	33.26 (7,478)	146 (5.7)	68,376 (150,426)	59.5 (13,377)
		10	14.28 (3,210)	33.42 (7,513)	16.63 (3,739)	291 (11.5)	17094 (37,607)	73.5 (16,524)

SERVOACTUATOR PERFORMANCE HIGH VOLTAGE

Servomotor Stack Number	Servoactuator Base Mass kg (lb)	Screw Lead mm	Continuous Stall Force kN (lbf)	Peak Stall Force kN (lbf)	Brake Holding Force kN (lbf)	Maximum Speed mm/sec (in/sec)	Maximum Linear Inertia kg (lb)	Dynamic Load Rating kN (lbf)
-8	21.5 (47.3)	5	27.76 (6,242)	66.84 (15,026)	33.26 (7,478)	146 (5.7)	68376 (150,426)	59.5 (13,377)
		10	13.88 (3,121)	33.42 (7,513)	16.63 (3,739)	291 (11.5)	17094 (37,607)	73.5 (16,524)

DEFINITIONS

Continuous Stall Force:

Force produced by the servoactuator at the continuous servomotor torque and at zero speed. Continuous force declines as servomotor speed increases. Consult performance curves for force rating at higher speeds. Continuous servomotor torque is limited by temperature and thus, the continuous force will be reduced with ambient temperatures above 25°C (77°F).

Peak Stall Force: Force produced by the servoactuator at the peak servomotor torque and at zero speed. Peak force declines as servomotor speed increases. Consult performance curves for force rating at higher speeds. Peak force can be held only for short durations (typically less than 1 minute) after which a cool down period at less than the continuous rating is required.

Brake Holding Force: Maximum force that the optional brake will hold stationary. Brake should not be used to stop a moving servoactuator as damage to the brake will result.

Maximum Static Load: Mechanical load limit of the servoactuator components. This is a limitation of the structural components of the servoactuator.

Dynamic Load Rating: The load at which the estimated life of a ballscrew or bearing will be 1 million revolutions

Maximum Speed: The maximum linear speed for the servoactuator. The available force at maximum speed is significantly less than the Stall Forces. Consult the Performance curves for Force/Speed relationship.

Accuracy: The ability of a positioning system to move exactly to a commanded position.

Repeatability: The ability of a positioning system to return to the same point from the same direction with the same load.

Resolution: The smallest positioning increment possible.

Lead Accuracy: The maximum deviation from nominal lead over specified interval.

Maximum Linear Inertia: This is the maximum load mass that can be connected to the servoactuator. This mass results in 10:1 inertia match to servomotor with 180 mm stroke. Increasing stroke length will reduce this value while reducing stroke will increase this value. For exact inertia matching, refer to EMA sizing software.

Servoactuator Base Mass: This is the mass of the servoactuator with 0" stroke. To get total servoactuator mass multiply stroke X servoactuator mass adder and add to servoactuator base mass.

SIZE 5

LOW VOLTAGE

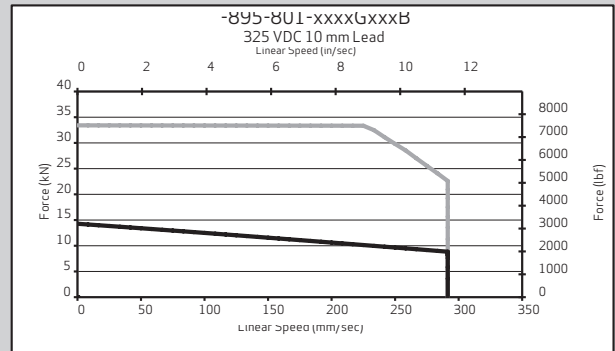
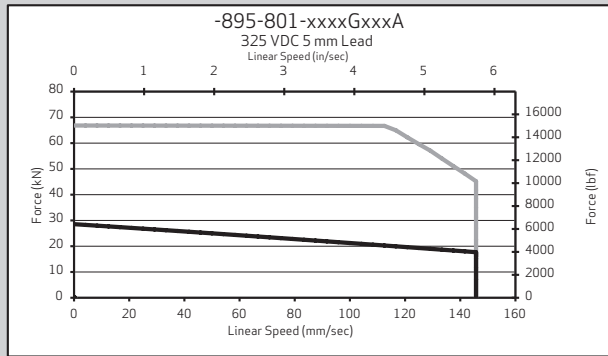

HIGH VOLTAGE

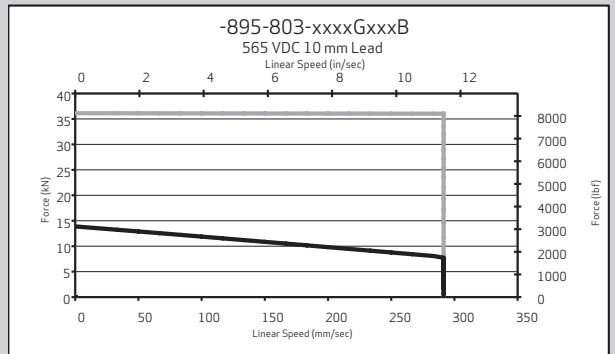
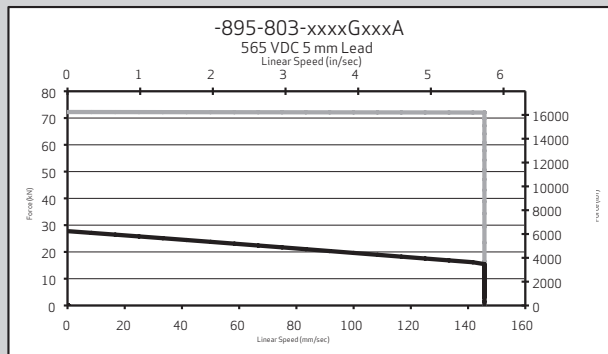

Continuous Force
Peak Force

SERVOACTUATOR

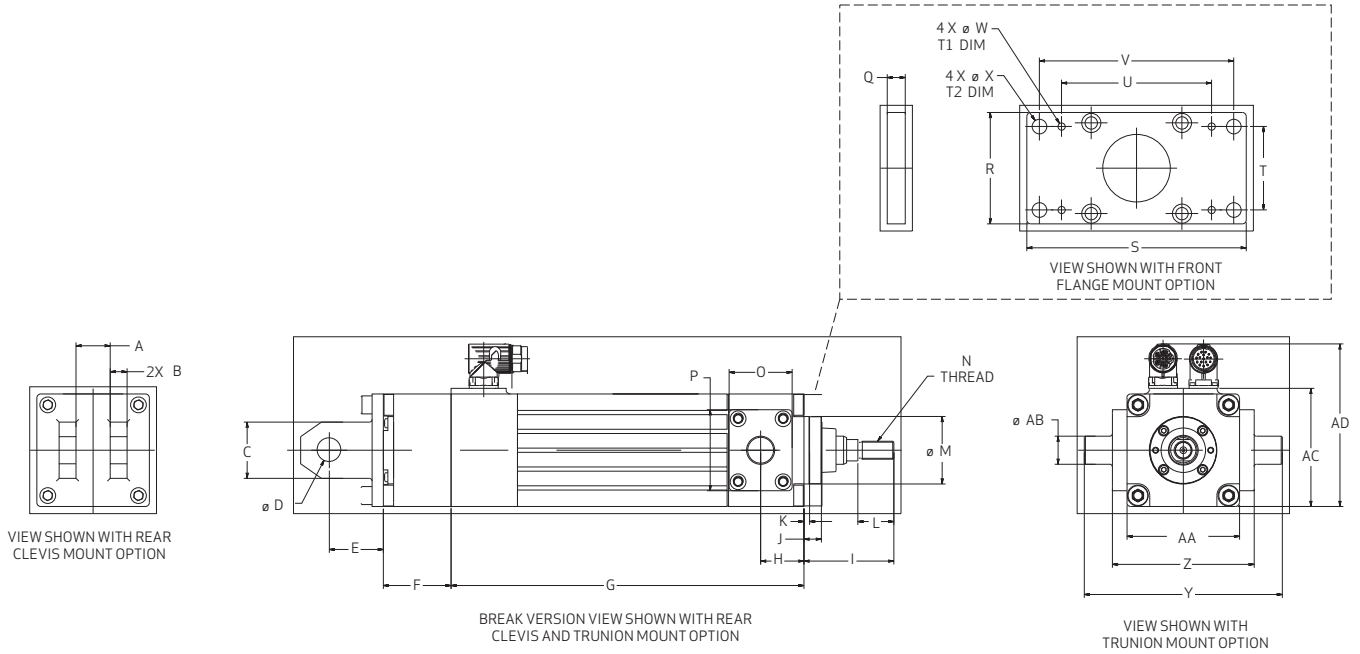

SIZE 3

Dimensions mm (in)		(brake only)														
A	B	C	D	E	F	G150	G300	H	I	J	K	L	M	N	O	
20.4 (.80)	10 (.39)	35 (1.38)	14 (.55)	29 (1.14)	44.3 (1.74)	313.5 (12.34)	463.5 (18.25)	33 (1.30)	62 (2.40)	12.3 (.49)	3.5 (.14)	20 (.79)	50.8 (2.00)	M12 -	51 (2.01)	
P	Q	R	S	T1	T2	U	V	W	X	Y	Z	AA	AB	AC	AD	
51 (2.01)	12 (.47)	76 (2.99)	150 (5.91)	62 (2.40)	62 (2.40)	93.7 (3.69)	133.4 (5.25)	6.4 (.25)	10.7 (.42)	148.2 (5.84)	98.2 (3.87)	76.2 (3.0)	20 (.79)	80 (3.15)	119 (4.69)	

SIZE 4

Dimensions mm (in)		(brake only)														
A	B	C	D	E	F	G150	G300	H	I	J	K	L	M	N	O	
30.4 (1.20)	15 (.59)	50 (1.97)	20 (.79)	48 (1.89)	41.1 (1.62)	324.6 (12.78)	474.6 (18.69)	38.5 (1.52)	79.9 (3.15)	15.5 (.61)	5 (.20)	32 (1.26)	59.99 (2.36)	M16 -	56 (2.20)	
P	Q	R	S	T1	T2	U	V	W	X	Y	Z	AA	AB	AC	AD	
72 (2.83)	16 (.63)	99 (3.90)	195 (7.68)	74.2 (2.92)	74.2 (2.92)	133.4 (5.25)	172.7 (6.80)	6.4 (.25)	13 (.51)	176 (6.93)	126 (4.96)	100 (3.94)	24.98 (.983)	105 (4.13)	144 (5.67)	

SIZE 5

Dimensions mm (in)		(brake only)														
A	B	C	D	E	F	G150	G300	H	I	J	K	L	M	N	O	
40.4 (1.59)	17 (.67)	72 (2.83)	28 (1.10)	59 (2.32)	52 (2.05)	385 (15.16)	505 (19.88)	53 (2.09)	114 (4.49)	18 (.71)	5 (.20)	50 (1.97)	88 (3.46)	M27 -	75 (2.95)	
P	Q	R	S	T1	T2	U	V	W	X	Y	Z	AA	AB	AC	AD	
99 (3.90)	17.5 (.69)	150 (5.91)	240 (9.45)	85.6 (3.37)	123.8 (4.87)	193.7 (7.63)	193.7 (7.63)	6.4 (.25)	13 (.51)	241.5 (9.51)	173.5 (6.83)	139.5 (5.49)	40 (1.57)	139.5 (5.49)	178 (7.01)	

ROD END KITS

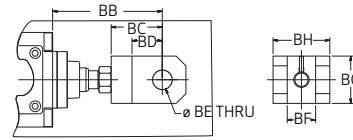

ROD END KIT, CLEVIS END OPTION

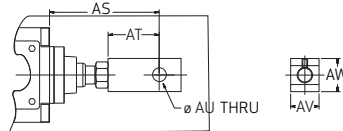

ROD EYE KIT, SPADE OPTION

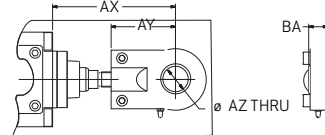

ROD END KIT, SPHERICAL BEARING OPTION

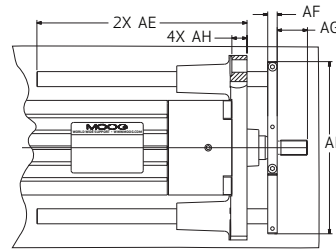

ANTI-ROTATION OPTION

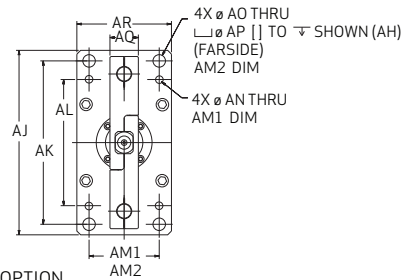

SIZE 3

Dimensions mm (in)																
AE150	AE300	AE180	AF	AG	AH	AI	AJ	AK	AL	AM1	AM2	AN	AO	AP	AQ	
224	374	-	10	20	12	151	150	133	94	62	62	6.4	10.7	18	25	
(8.82)	(14.72)	-	(.39)	(.79)	(.47)	(5.94)	(5.91)	(5.24)	(3.7)	(2.4)	(2.4)	(.25)	(.42)	(.71)	(.98)	
AR	AS	AT	AU	AV	AW	AX	AY	AZ	BA	BB	BC	BD	BE	BF	BG	BH
76	78	36	12	16	22	90	48	16	14	78	36	20	12	16	32	32
(2.99)	(3.07)	(1.4)	(.47)	(.63)	(.87)	(3.54)	(1.9)	(.63)	(.55)	(3.07)	(1.4)	(.79)	(.47)	(.63)	(1.26)	(1.26)

SIZE 4

Dimensions mm (in)																
AE150	AE300	AE180	AF	AG	AH	AI	AJ	AK	AL	AM1	AM2	AN	AO	AP	AQ	
221.1	372.1	-	10	32	16	182	195	172.7	133.4	74.2	74.2	6.4	13.2	21	30	
(8.71)	(14.65)	-	(.39)	(1.26)	(.63)	(7.17)	(7.68)	(6.8)	(5.25)	(2.92)	(2.92)	(.25)	(.52)	(.83)	(1.18)	
AR	AS	AT	AU	AV	AW	AX	AY	AZ	BA	BB	BC	BD	BE	BF	BG	BH
100	115.9	54	20	30	35	129.9	68	25	20	115.9	54	32	20	30	50	60
(3.94)	(4.56)	(2.13)	(.79)	(1.18)	(1.38)	(5.11)	(2.68)	(.98)	(.78)	(4.56)	(2.13)	(1.26)	(.79)	(1.18)	(1.97)	(2.36)

SIZE 5

Dimensions mm (in)																
AE150	AE300	AE180	AF	AG	AH	AI	AJ	AK	AL	AM1	AM2	AN	AO	AP	AQ	
-	381.7	261.7	16	53	17.5	250	240	194	194	82.6	123.8	6.4	13.2	21	41	
-	(15.03)	(10.3)	(.63)	(2.09)	(.69)	(9.84)	(9.45)	(7.64)	(7.64)	(3.25)	(4.87)	(.25)	(.52)	(.83)	(1.61)	
AR	AS	AT	AU	AV	AW	AX	AY	AZ	BA	BB	BC	BD	BE	BF	BG	BH
150	162	75	28	40	50	192	105	40	28	162	75	39	28	40	60	83
(5.91)	(6.38)	(2.95)	(1.1)	(1.57)	(1.97)	(7.56)	(4.13)	(1.57)	(1.1)	(6.38)	(2.95)	(1.54)	(1.1)	(1.57)	(2.36)	(3.27)

ELECTRICAL SCHEMATIC WITH ENCODER

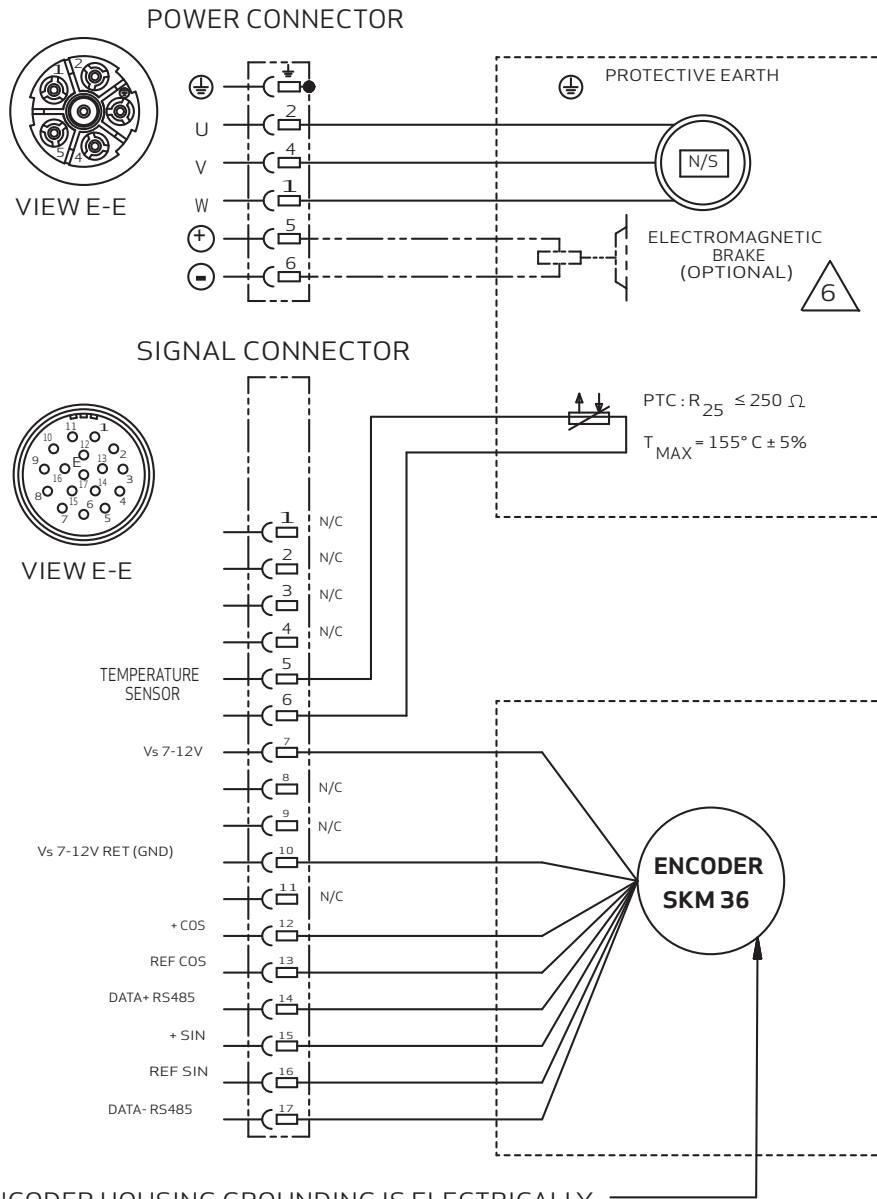

ELECTRICAL SCHEMATIC WITH ENCODER



(CODE: 1 OR 3)



CABLES (XXX = LENGTH IN METERS)
ENCODER: CA65132-003-XXX
POWER:
300V: C22294-002-XXX
600V: CA15987-002-XXX



ENERGIZE BRAKE TO RUN

TYPE CODE

STANDARD ELECTRIC LINEAR SERVOACTUATORS

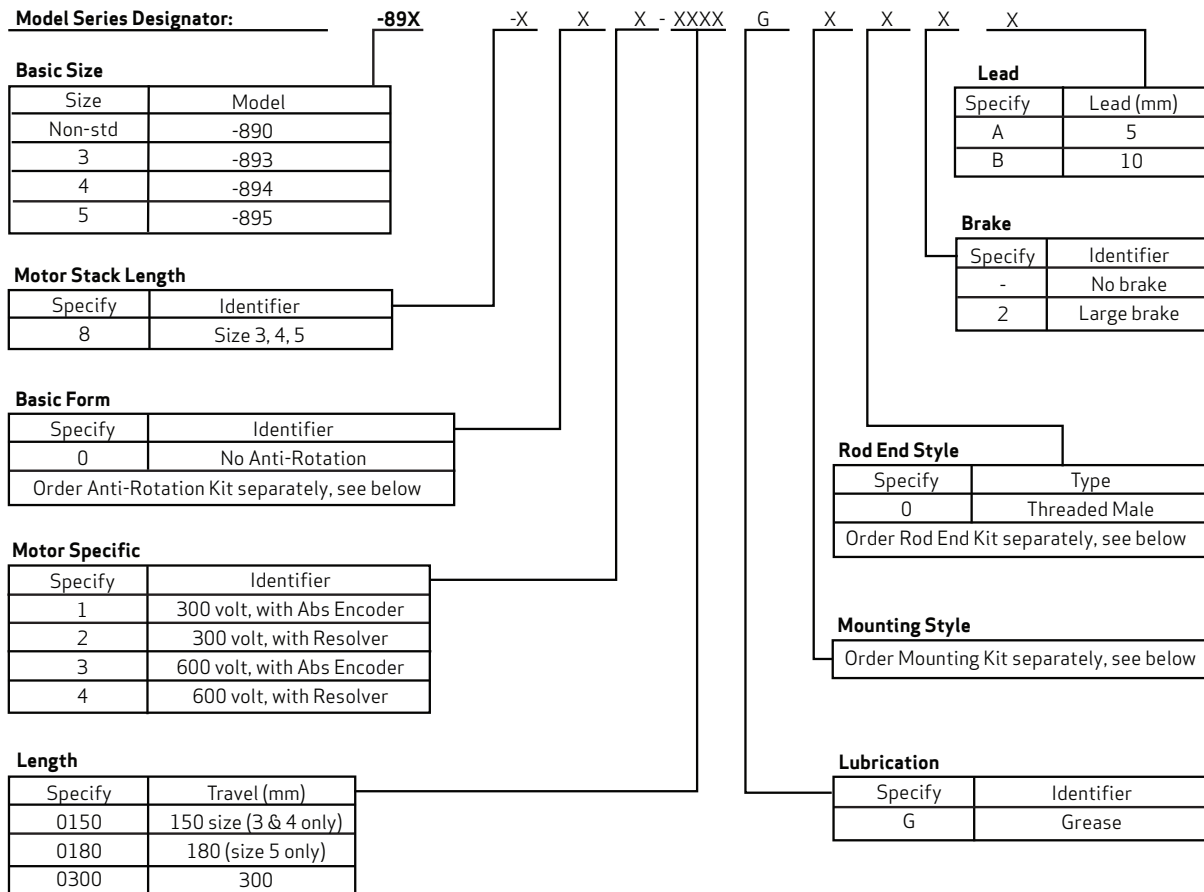

ORDERING CODES FOR SERVOACTUATOR KITS

Anti-Rotation Kit	
Front flange kit included as part of anti-rotation kit. "xxx" indicates length in mm. (example: 150 for 150mm stroke length)	CA 73092-003-XXX (size 3) CA 73092-004-XXX (size 4) CA 73092-005-XXX (size 5)

Mounting Kit	
Front Flange - (Included when anti-rotation option is used)	CA32703-003 (size 3) CA32703-004 (size 4) CA32703-005 (size 5)
Trunnion - Not available with anti-rotation	CA32702-003 (size 3) CA32702-004 (size 4) CA32702-005 (size 5)
Rear Clevis	CA32701-003 (size 3) CA32701-004 (size 4) CA32701-005 (size 5)

Rod End Kit	
Rod End Male	Standard
Rod End Clevis	CA30131-003 (size 3) CA30131-004 (size 4) CA30131-005 (size 5)
Rod Eye Spade	CA30132-003 (size 3) CA30132-004 (size 4) CA30132-005 (size 5)
Spherical Bearing	CA30133-003 (size 3) CA30133-004 (size 4) CA30133-005 (size 5)

TECHNICAL DATA AND ORDERING INFORMATION

Electrical Characteristics	
Power supply	3-phase, 65 Vac to 510 Vac, 1 phase, 103 to 243 VAC
Auxiliary power supply	24 Vdc, 2A
PWM Frequency	10 kHz
Position control loop Frequency	8 kHz
Speed control loop frequency	8 kHz
Continuous / peak output current	8A/22A with 3-phase supply; 6A/6A with single phase supply (Size 3); 10A/42A with 3-phase supply (Size 4); 20A/45A with 3-phase supply (Size 5)
Certifications include	
	UL, CE, ODVA
Environmental data	
Operating ambient temperature	0 to 40°C
Storage Temperature	-25 to +55°C
Thermal Protection	70°C to de-rating the servodrive
Ingress Protection	IP20
Protection	
	Servomotor and servodrive over temperature Out of tolerance power supply detection Encoder/Resolver missing signal detection Output Open/Short circuit detection I ² T limiting Thermal foldback

FIELD BUS

High-speed interfaces provide a fully digital link for receiving motion commands, providing feedback of status and initializing controller parameters.

Supported Fieldbuses include:

DeviceNet, Ethernet IP, and 16 bit Analog with Encoder Repeat.

Servomotor Feedback Supported:

Stegmann Absolute Encoders, Encoder Simulated Output

Digital I/O

- Hardware enable input for process control
- Servomotor Brake Control Output
- Servodrive Ready Output
- Additional 7 programmable inputs and 3 programmable outputs allowing for custom servodrive functionality and monitoring

SERVODRIVE ORDERING CODES

Servodrive Size A for Size 3 Servoactuator	
No FieldBus	G362-R08-00-B-902E
DeviceNet	G362-R08-40-A-902E
Ethernet IP	G362-R08-90-B-902E
16 Bit analog with encoder +/- 10v, 0-20mA	G362-R08-70-C-902E
Servodrive Size B for Size 4 Servoactuator	
No Fieldbus	G362-014-00-B-902E
DeviceNet	G362-014-40-A-902E
Ethernet IP	G362-014-90-A-902E
16 Bit analog with encoder +/- 10v, 0-20mA	G362-014-70-C-902E
Servodrive Size C for Size 5 Servoactuator	
No Fieldbus	G362-020-00-B-902E
DeviceNet	G362-020-40-A-902E
Ethernet IP	G362-020-90-B-902E
16 Bit analog with encoder repeat +/- 10v, 0-20mA	G362-020-70-C-902E

CONNECTIONS AND DIMENSIONS

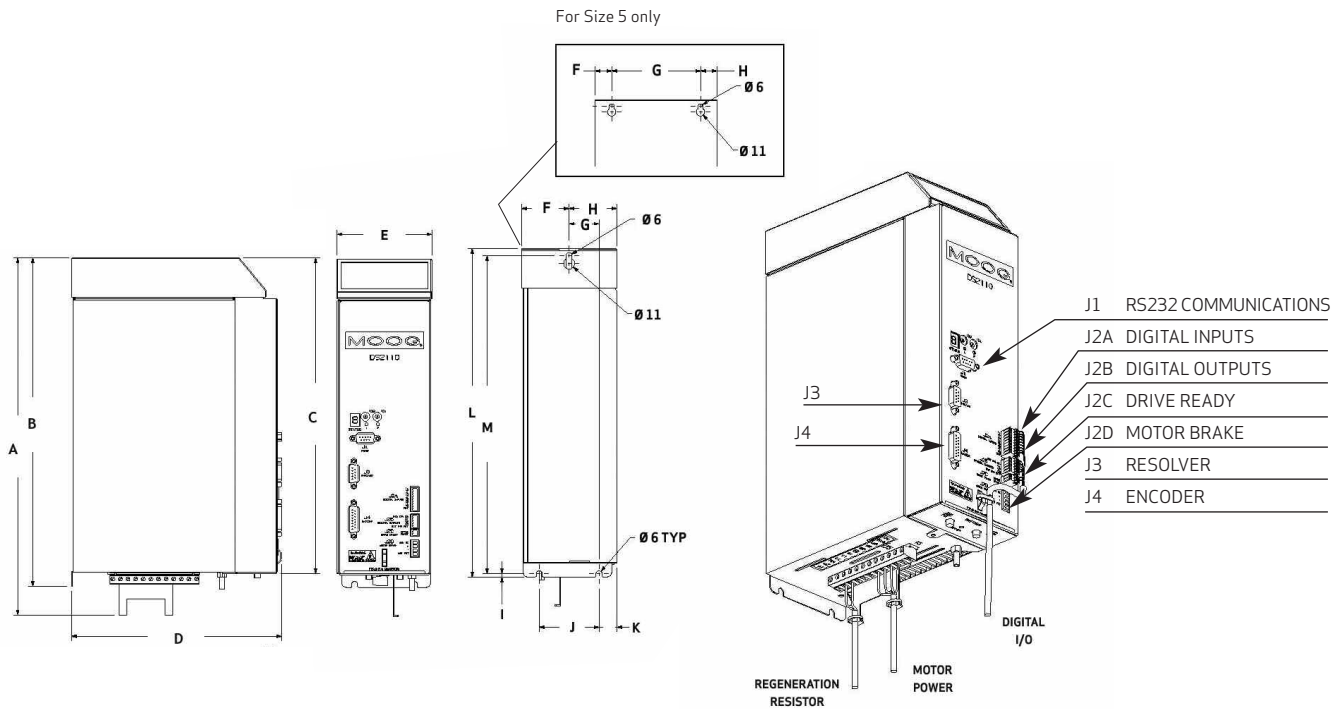

SERVO DRIVE SIZE A FOR SIZE 3 SERVOACTUATOR

Dimensions mm (in)		A	B	C	D	E	F	G	H	I	J	K	L	M
		359 (14.1)	330 (13.0)	317.2 (12.5)	210.3 (8.3)	95.5 (3.8)	47.8 (1.88)	30 (1.18)	47.8 (1.88)	3.5 (0.14)	60 (2.36)	18 (0.71)	330 (13.0)	319.5 (12.6)

SERVO DRIVE SIZE B FOR SIZE 4 SERVOACTUATOR

Dimensions mm (in)		A	B	C	D	E	F	G	H	I	J	K	L	M
		359 (14.1)	330 (13.0)	317.2 (12.5)	210.3 (8.3)	120 (4.7)	75 (2.95)	14.8 (0.60)	45 (1.78)	3.5 (0.14)	28.5 (1.12)	60 (2.36)	330 (13.0)	319.5 (12.6)

SERVO DRIVE SIZE C FOR SIZE 5 SERVOACTUATOR

Dimensions mm (in)		A	B	C	D	E	F	G	H	I	J	K	L	M
		439 (17.3)	410 (16.1)	397.2 (15.6)	211.1 (8.31)	165 (6.50)	22.5 (0.89)	120 (4.72)	22.5 (0.89)	3.5 (0.14)	120 (4.72)	22.5 (0.89)	410 (16.1)	402.5 (15.8)

TAKE A CLOSER LOOK.

Solutions for Moog's Standard Electric Linear Servoactuation Package for high performance applications are readily available by calling +1 716 652 2000 or emailing us at info.usa@moog.com

For more information, visit our Web site or locate the distributor nearest you at www.moog.com/industrial/distributorlocator.

www.moog.com/industrial

Moog is a registered trademark of Moog Inc. All trademarks as indicated herein are the property of Moog, Inc. and its subsidiaries. All rights reserved.
©2009 Moog, Inc.

Standard Electric Linear Actuation Package
TJW/PDF/CDL26660 Rev. A - 0709