

BN42 Specifications

Inside Rotor
Brushless Motors

BN42 SPECIFICATIONS - *Continuous Stall Torque 144 - 519 oz-in (1.02 - 3.67 Nm)* *Peak Torque 609 - 2560 oz-in (4.30 - 18.1 Nm)*

Part Number*		BN42-23AF- [] [] [] []			BN42-33AF- [] [] [] []			BN42-43AF- [] [] [] []			BN42-53AF- [] [] [] []		
		01	02	03	01	02	03	01	02	03	01	02	03
Winding Code**		01	02	03	01	02	03	01	02	03	01	02	03
	L = Length	inches			3.30			4.30			5.30		
		millimeters			83.8			109.2			134.6		
Terminal Voltage	volts DC	24.0	50.0	100.0	24.0	50.0	100.0	24.0	50.0	100.0	24.0	50.0	100.0
Peak Torque	oz-in	609.0	609.0	609.0	1248.0	1248.0	1248.0	1906.0	1906.0	1906.0	2560.0	2560.0	2560.0
	Nm	4.3005	4.3005	4.3005	8.8128	8.8128	8.8128	13.4592	13.4592	13.4592	18.0774	18.0774	18.0774
Continuous Stall Torque	oz-in	144.0	156.0	155.0	266.0	281.0	287.0	387.0	398.0	407.0	496.0	510.0	519.0
	Nm	1.0169	1.1016	1.0945	1.8784	1.9843	2.0267	2.7328	2.8105	2.8740	3.5025	3.6014	3.6649
Rated Speed	RPM	6050.0	5950.0	6140.0	3710.0	4710.0	4710.0	2380.0	3840.0	3840.0	1740.0	2820.0	2820.0
	rad/sec	634	623	643	389	493	493	249	402	402	182	295	295
Rated Torque	oz-in	102.0	113.0	110.0	213.0	198.0	200.0	340.0	290.0	296.0	451.0	413.0	419.0
	Nm	0.7203	0.7979	0.7768	1.5041	1.3982	1.4123	2.4009	2.0478	2.0902	3.1847	2.9164	2.9588
Rated Current	Amps	22.60	11.70	5.90	28.90	16.20	8.20	29.70	19.20	9.80	29.20	20.20	10.20
Rated Power	watts	456.0	497.0	499.0	584.0	690.0	697.0	598.0	824.0	841.0	580.0	861.0	874.0
Torque Sensitivity	oz-in/amp	5.20	11.00	21.40	8.41	14.00	28.00	12.90	17.20	34.30	17.40	23.10	46.30
	Nm/amp	0.0367	0.0777	0.1511	0.0594	0.0989	0.1977	0.0911	0.1215	0.2422	0.1229	0.1631	0.3269
Back EMF	volts/KRPM	3.80	8.20	15.80	6.22	10.40	20.70	9.52	12.70	25.40	12.80	17.10	34.20
	volts/rad/sec	0.0367	0.0777	0.1511	0.0594	0.0989	0.1977	0.0911	0.1215	0.2422	0.1229	0.1631	0.3269
Terminal Resistance	ohms	0.040	0.154	0.584	0.039	0.095	0.364	0.052	0.084	0.320	0.065	0.106	0.408
Terminal Inductance	mH	0.090	0.408	1.540	0.115	0.318	1.270	0.178	0.316	1.260	0.241	0.428	1.710
Motor Constant	oz-in/sq.rt.watt	26.00	28.03	28.00	42.59	45.42	46.41	56.57	59.35	60.63	68.25	70.95	72.49
	Nm/sq.rt.watt	0.18360	0.19794	0.19775	0.30072	0.32075	0.32772	0.39947	0.41907	0.42817	0.48194	0.50102	0.51186
Rotor Inertia	oz-in-sec ² x10 ⁻³	18.00	18.00	18.00	35.00	35.00	35.00	52.00	52.00	52.00	70.00	70.00	70.00
	g-cm ²	1270.3	1270.3	1270.3	2470.0	2470.0	2470.0	3669.6	3669.6	3669.6	4939.9	4939.9	4939.9
Weight	oz	65.0	65.0	65.0	104.0	104.0	104.0	143.0	143.0	143.0	182.0	182.0	182.0
	g	1846.0	1846.0	1846.0	2953.6	2953.6	2953.6	4061.2	4061.2	4061.2	5168.8	5168.8	5168.8
# of Poles		8.0	8.0	8.0	8.0	8.0	8.0	8.0	8.0	8.0	8.0	8.0	
Timing		120°	120°	120°	120°	120°	120°	120°	120°	120°	120°	120°	
Mech. Time Constant	ms	3.8	3.2	3.2	2.7	2.4	2.3	2.3	2.1	2.0	2.1	2.0	1.9
Electrical Time Constant	ms	2.25	2.65	2.64	2.95	3.35	3.49	3.42	3.76	3.94	3.71	4.04	4.19
Thermal Resistivity	deg. C/watt	1.2	1.2	1.2	1.0	0.9	0.9	0.9	0.8	0.8	0.9	0.7	0.7
Speed/Torque Gradient	rpm/oz-in	2.0	1.7	1.7	0.7	0.7	0.6	0.4	0.4	0.4	0.3	0.3	0.3

Notes:

- Motor mounted to a 10 x 10 x 1/4 inches aluminum plate, still air.
- Maximum winding temperature of 155°C.
- Typical electrical specifications at 25°C.
- Motor Terminal Voltages are representative only; motors may be operated at voltages other than those listed in the table. For assistance please contact our applications engineer.
- For MS (military style) connector, please specify connector housing and terminal.
- Data for informational purposes only. Should not be considered a binding performance agreement. For specific applications, please contact the factory.

*Many other custom mechanical options are available – consult factory.

**Many other winding options are available – consult factory.

Select your options below and place their code in its corresponding block as shown on page 5.

- | | | |
|--|---|--|
| <input checked="" type="checkbox"/> TERMINATION | <input checked="" type="checkbox"/> FEEDBACK OPTIONS | <input checked="" type="checkbox"/> OTHER OPTIONS |
| L – Leads (std) | H – Hall Effect (std) | E – Encoder |
| C – Connector | R – Resolver | G – Gearhead |
| M – MS connector | S – Sensorless | |

BN42 Typical Outline

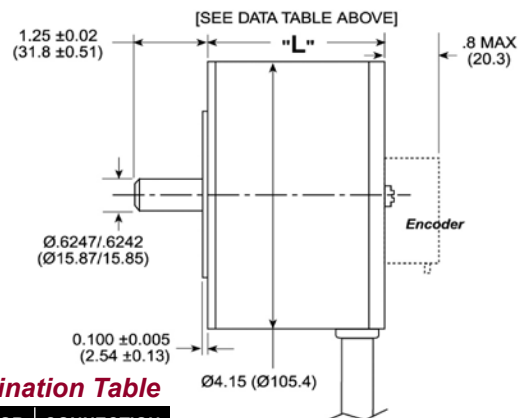
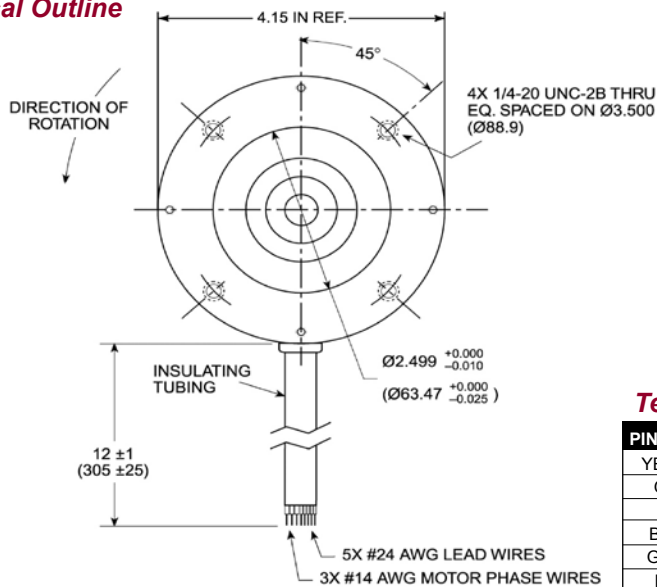

Termination Table

PIN COLOR	CONNECTION
YELLOW	V _{CC}
GRAY	GROUND
RED	A COIL
BLACK	B COIL
GREEN	C COIL
BLUE	S2 OUT
BROWN	S1 OUT
ORANGE	S3 OUT

Dimensions are in inches (millimeters)

Note: An optional 4.15 (105.4) square front end cap is available.

REVISED 05/19

BN42 Performance Curves

BN42 Performance Curves

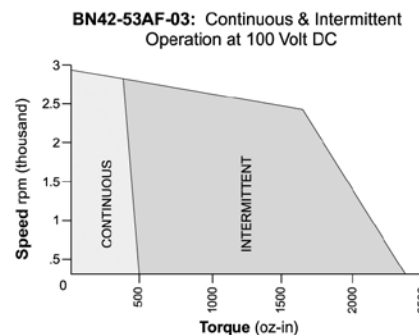
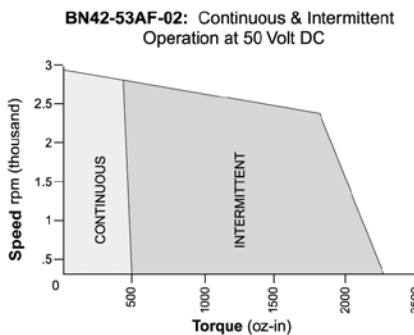
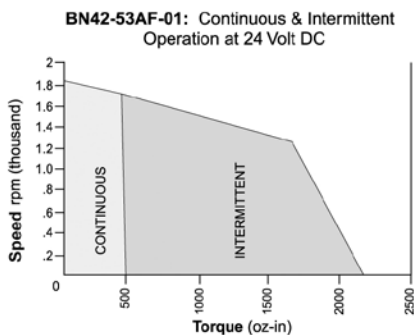
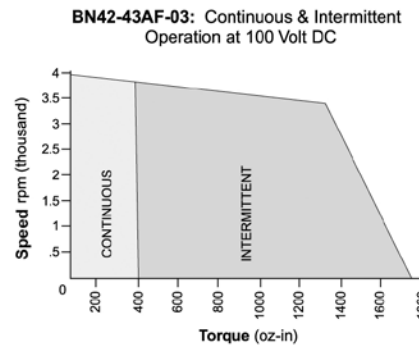
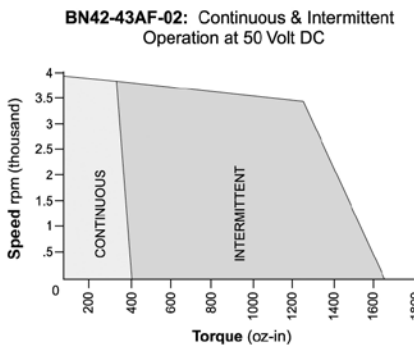
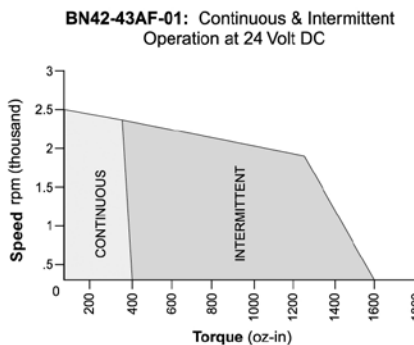
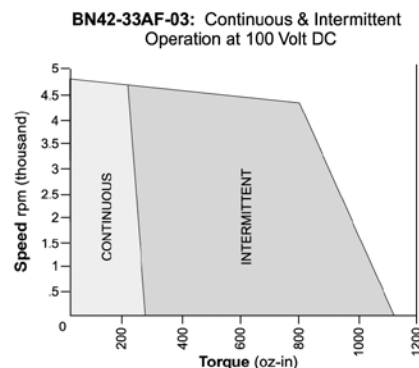
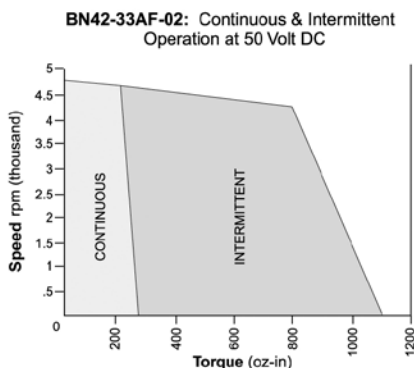
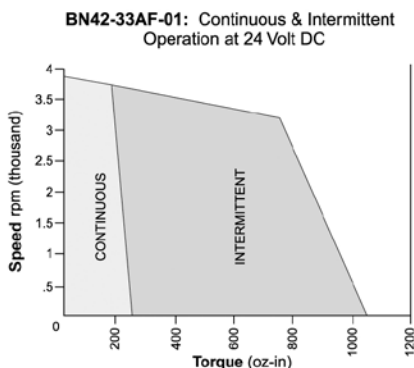
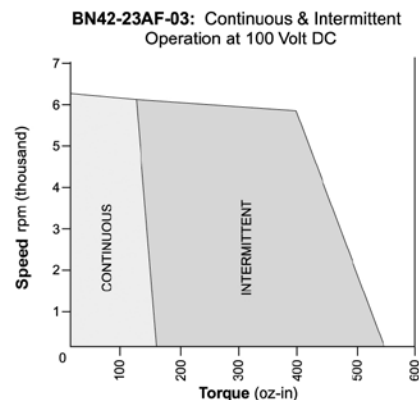
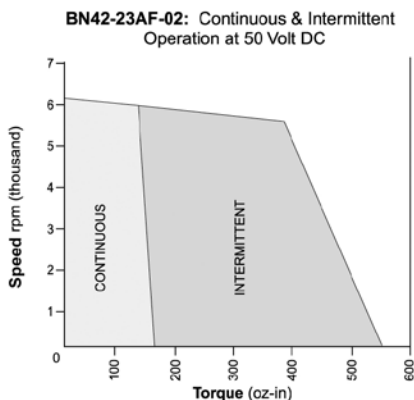
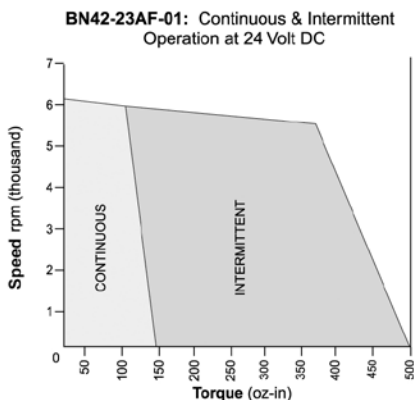

Note: Intermittent operation is based on a 20% duty cycle of one minute on, four minutes off.
Please contact the factory regarding the duty cycle of your application.

BN42 EU Specifications

BN42 EU SPECIFICATIONS -

Continuous Stall Torque 144 - 519 oz-in (1.02 - 3.67 Nm)
Peak Torque 609 - 2560 oz-in (4.30 - 18.1 Nm)

Inside Rotor
Brushless Motors

Part Number*		BN42-23EU- <input type="checkbox"/> <input type="checkbox"/> <input type="checkbox"/> <input type="checkbox"/>			BN42-33EU- <input type="checkbox"/> <input type="checkbox"/> <input type="checkbox"/> <input type="checkbox"/>			BN42-43EU- <input type="checkbox"/> <input type="checkbox"/> <input type="checkbox"/> <input type="checkbox"/>			BN42-53EU- <input type="checkbox"/> <input type="checkbox"/> <input type="checkbox"/> <input type="checkbox"/>		
Winding Code**		01	02	03	01	02	03	01	02	03	01	02	03
L = Length	inches	2.30			3.30			4.30			5.30		
	millimeters	58.5			83.9			109.3			134.7		
Terminal Voltage	volts DC	24	50	100	24	50	100	24	50	100	24	50	100
Peak Torque	oz-in	609	609	609	1248	1248	1248	1906	1906	1906	2560	2560	2560
	Nm	4.30	4.30	4.30	8.82	8.82	8.82	13.5	13.5	13.5	18.1	18.1	18.1
Continuous Stall Torque	oz-in	144	156	155	266	281	287	387	398	407	496	510	519
	Nm	1.02	1.11	1.10	1.88	1.99	2.03	2.74	2.81	2.88	3.51	3.61	3.67
Rated Speed	RPM	6050	5950	6140	3710	4710	4710	2380	3840	3840	1740	2820	2820
	rad/sec	634	623	643	389	494	494	250	403	403	183	296	296
Rated Torque	oz-in	102	113	110	213	198	200	340	290	296	451	413	419
	Nm	0.721	0.798	0.777	1.51	1.40	1.42	2.41	2.05	2.09	3.19	2.92	2.96
Rated Current	Amps	22.6	11.7	5.9	28.9	16.2	8.2	29.7	19.2	9.8	29.2	20.2	10.2
Rated Power	watts	456	497	499	584	690	697	598	824	841	580	861	874
Torque Sensitivity	oz-in/amp	5.20	11.0	21.4	8.41	14.0	28.0	12.9	17.2	34.3	17.4	23.1	46.3
	Nm/amp	0.0363	0.0783	0.151	0.0594	0.0992	0.198	0.0909	0.122	0.243	0.123	0.164	0.327
Back EMF	volts/KRPM	3.80	8.20	15.8	6.22	10.4	20.7	9.52	12.7	25.4	12.8	17.1	34.2
	volts/rad/sec	0.0363	0.0783	0.151	0.0594	0.0992	0.198	0.0909	0.122	0.243	0.123	0.164	0.327
Terminal Resistance	ohms	0.040	0.154	0.584	0.039	0.095	0.364	0.052	0.084	0.320	0.065	0.106	0.408
Terminal Inductance	mH	0.090	0.408	1.54	0.115	0.318	1.27	0.178	0.316	1.26	0.241	0.428	1.71
Motor Constant	oz-in/sq.rt.watt	27.8	28.6	28.2	45.7	46.8	46.8	59.5	61.2	61.1	71.0	73.0	72.9
	Nm/sq.rt.watt	0.197	0.202	0.199	0.323	0.331	0.331	0.421	0.433	0.432	0.502	0.516	0.515
Rotor Inertia	oz-in-sec ²	0.018	0.018	0.018	0.035	0.035	0.035	0.052	0.052	0.052	0.070	0.070	0.070
	g-cm ²	1271	1271	1271	2472	2472	2472	3672	3672	3672	4943	4943	4943
Weight	oz	65	65	65	104	104	104	143	143	143	182	182	182
	g	1843	1843	1843	2949	2949	2949	4054	4054	4054	5160	5160	5160

Notes:

- Motor mounted to a 10 x 10 x 1/4 inches aluminum plate, still air.
- Maximum winding temperature of 155°C.
- Typical electrical specifications at 25°C.
- Motor Terminal Voltages are representative only; motors may be operated at voltages other than those listed in the table. For assistance please contact our applications engineer.
- For MS (military style) connector, please specify connector housing and terminal.
- Data for informational purposes only. Should not be considered a binding performance agreement. For specific applications, please contact the factory.

*Many other custom mechanical options are available – consult factory.

**Many other winding options are available – consult factory.

Select your options below and place their code in its corresponding block as shown on page 5.

- | | | |
|--|---|--|
| <input checked="" type="checkbox"/> TERMINATION | <input checked="" type="checkbox"/> FEEDBACK OPTIONS | <input checked="" type="checkbox"/> OTHER OPTIONS |
| L – Leads (std) | H – Hall Effect (std) | E – Encoder |
| C – Connector | R – Resolver | G – Gearhead |
| M – MS connector | S – Sensorless | |

BN42 EU Typical Outline

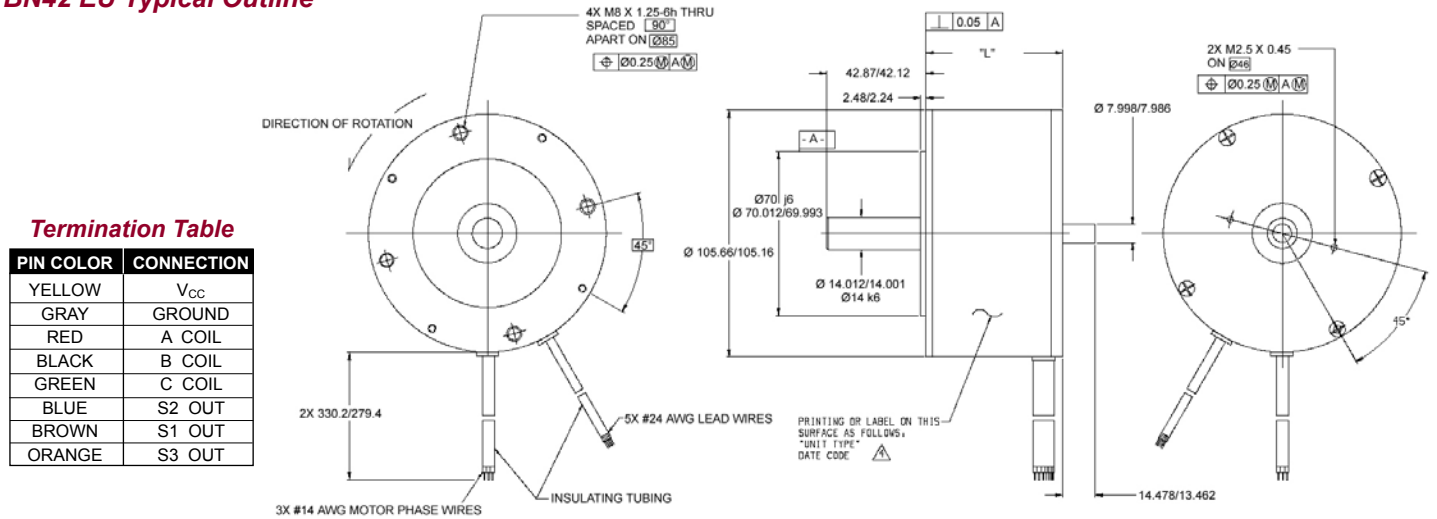

Dimensions are in inches

Termination Table

PIN COLOR	CONNECTION
YELLOW	V _{CC}
GRAY	GROUND
RED	A COIL
BLACK	B COIL
GREEN	C COIL
BLUE	S2 OUT
BROWN	S1 OUT
ORANGE	S3 OUT

BN42 EU Performance Curves

BN42 EU Performance Curves

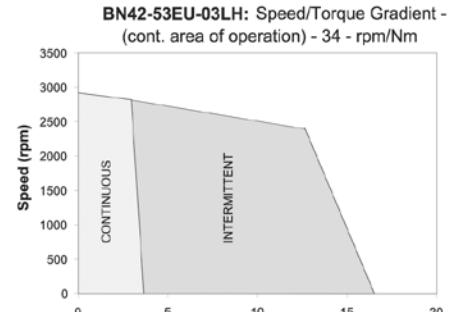
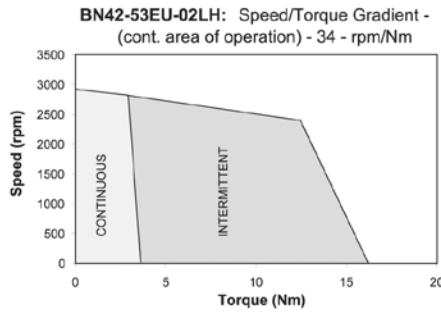
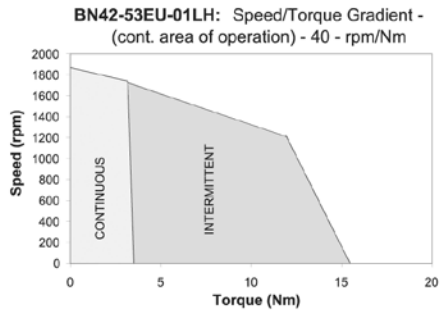
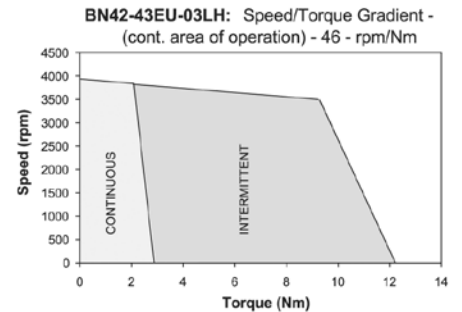
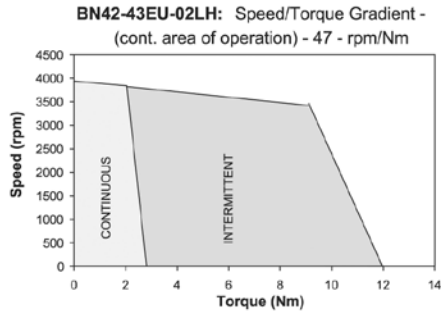
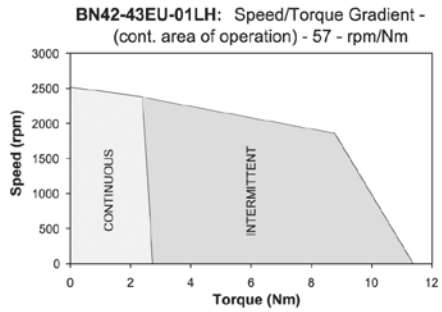
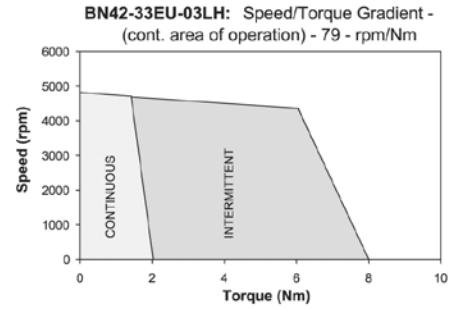
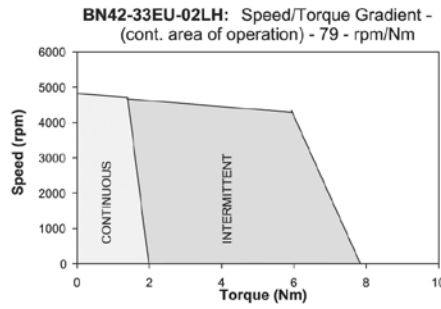
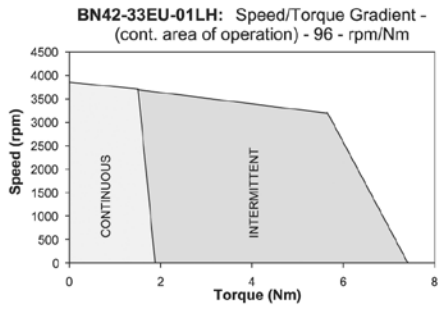
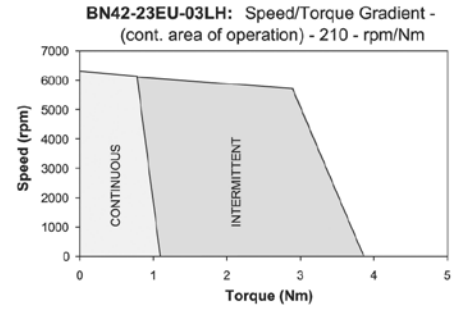
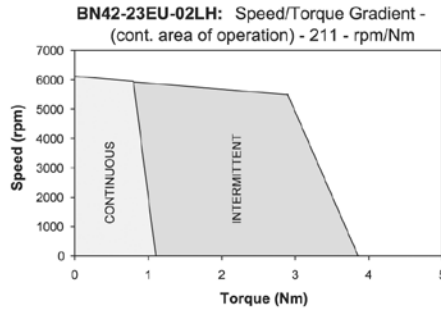
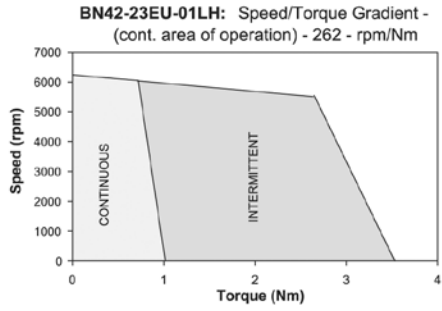

Note: Intermittent operation is based on a 20% duty cycle of one minute on, four minutes off. Please contact the factory regarding the duty cycle of your application.

BN42 IP65 Specifications

Inside Rotor
Brushless Motors

BN42 IP65 SPECIFICATIONS - Continuous Stall Torque 144 - 519 oz-in (1.02 - 3.67 Nm) Peak Torque 609 - 2560 oz-in (4.30 - 18.1 Nm)

Part Number*		BN42-23IP - <input type="checkbox"/> <input type="checkbox"/> <input type="checkbox"/> <input type="checkbox"/> <input type="checkbox"/> <input type="checkbox"/>			BN42-33IP - <input type="checkbox"/> <input type="checkbox"/> <input type="checkbox"/> <input type="checkbox"/> <input type="checkbox"/> <input type="checkbox"/>			BN42-43IP - <input type="checkbox"/> <input type="checkbox"/> <input type="checkbox"/> <input type="checkbox"/> <input type="checkbox"/> <input type="checkbox"/>			BN42-53IP - <input type="checkbox"/> <input type="checkbox"/> <input type="checkbox"/> <input type="checkbox"/> <input type="checkbox"/> <input type="checkbox"/>		
Winding Code**		01	02	03	01	02	03	01	02	03	01	02	03
L = Length	inches	2.30			3.30			4.30			5.30		
	millimeters	58.4			83.8			109.2			134.6		
Terminal Voltage	volts DC	24.0	50.0	100.0	24.0	50.0	100.0	24.0	50.0	100.0	24.0	50.0	100.0
Peak Torque	oz-in	609.0	609.0	609.0	1248.0	1248.0	1248.0	1906.0	1906.0	1906.0	2560.0	2560.0	2560.0
	Nm	4.3005	4.3005	4.3005	8.8128	8.8128	8.8128	13.4592	13.4592	13.4592	18.0774	18.0774	18.0774
Continuous Stall Torque	oz-in	144.0	156.0	155.0	266.0	281.0	287.0	387.0	398.0	407.0	496.0	510.0	519.0
	Nm	1.0169	1.1016	1.0945	1.8784	1.9843	2.0267	2.7328	2.8105	2.8740	3.5025	3.6014	3.6649
Rated Speed	RPM	6050.0	5950.0	6140.0	3710.0	4710.0	4710.0	2380.0	3840.0	3840.0	1740.0	2820.0	2820.0
	rad/sec	634	623	643	389	493	493	249	402	402	182	295	295
Rated Torque	oz-in	102.0	113.0	110.0	213.0	198.0	200.0	340.0	290.0	296.0	451.0	413.0	419.0
	Nm	0.7203	0.7979	0.7768	1.5041	1.3982	1.4123	2.4009	2.0478	2.0902	3.1847	2.9164	2.9588
Rated Current	Amps	22.60	11.70	5.90	28.90	16.20	8.20	29.70	19.20	9.80	29.20	20.20	10.20
Rated Power	watts	456.0	497.0	499.0	584.0	690.0	697.0	598.0	824.0	841.0	580.0	861.0	874.0
Torque Sensitivity	oz-in/amp	5.20	11.00	21.40	8.41	14.00	28.00	12.90	17.20	34.30	17.40	23.10	46.30
	Nm/amp	0.0367	0.0777	0.1511	0.0594	0.0989	0.1977	0.0911	0.1215	0.2422	0.1229	0.1631	0.3269
Back EMF	volts/KRPM	3.80	8.20	15.80	6.22	10.40	20.70	9.52	12.70	25.40	12.80	17.10	34.20
	volts/rad/sec	0.0367	0.0777	0.1511	0.0594	0.0989	0.1977	0.0911	0.1215	0.2422	0.1229	0.1631	0.3269
Terminal Resistance	ohms	0.040	0.154	0.584	0.039	0.095	0.364	0.052	0.084	0.320	0.065	0.106	0.408
Terminal Inductance	mH	0.090	0.408	1.540	0.115	0.318	1.270	0.178	0.316	1.260	0.241	0.428	1.710
Motor Constant	oz-in/sq.rt.watt	26.00	28.03	28.00	42.59	45.42	46.41	56.57	59.35	60.63	68.25	70.95	72.49
	Nm/sq.rt.watt	0.18360	0.19794	0.19775	0.30072	0.32075	0.32772	0.39947	0.41907	0.42817	0.48194	0.50102	0.51186
Rotor Inertia	oz-in-sec ² x10 ⁻³	18.00	18.00	18.00	35.00	35.00	35.00	52.00	52.00	52.00	70.00	70.00	70.00
	g-cm ²	1270.3	1270.3	1270.3	2470.0	2470.0	2470.0	3669.6	3669.6	3669.6	4939.9	4939.9	4939.9
Weight	oz	65.0	65.0	65.0	104.0	104.0	104.0	143.0	143.0	143.0	182.0	182.0	182.0
	g	1846.0	1846.0	1846.0	2953.6	2953.6	2953.6	4061.2	4061.2	4061.2	5168.8	5168.8	5168.8
# of Poles		8.0	8.0	8.0	8.0	8.0	8.0	8.0	8.0	8.0	8.0	8.0	8.0
Timing		120°	120°	120°	120°	120°	120°	120°	120°	120°	120°	120°	120°
Mech. Time Constant	ms	3.8	3.2	3.2	2.7	2.4	2.3	2.3	2.1	2.0	2.1	2.0	1.9
Electrical Time Constant	ms	2.25	2.65	2.64	2.95	3.35	3.49	3.42	3.76	3.94	3.71	4.04	4.19
Thermal Resistivity	deg. C/watt	1.2	1.2	1.2	1.0	0.9	0.9	0.9	0.8	0.8	0.9	0.7	0.7
Speed/Torque Gradient	rpm/oz-in	2.0	1.7	1.7	0.7	0.7	0.6	0.4	0.4	0.4	0.3	0.3	0.3

Notes:

- Motor mounted to a 10 x 10 x 1/4 inches aluminum plate, still air.
- Maximum winding temperature of 155°C.
- Typical electrical specifications at 25°C.
- Motor Terminal Voltages are representative only; motors may be operated at voltages other than those listed in the table. For assistance please contact our applications engineer.
- Calculated (theoretical) speed/torque gradient.
- For MS (military style) connector, please specify connector housing and terminal.
- Data for informational purposes only. Should not be considered a binding performance agreement. For specific applications, please contact the factory.

*Many other custom mechanical options are available – consult factory.

**Many other winding options are available – consult factory.

Select your options below and place their code in its corresponding block as shown on page 5.

- | | | |
|--|---|--|
| <input checked="" type="checkbox"/> TERMINATION | <input checked="" type="checkbox"/> FEEDBACK OPTIONS | <input checked="" type="checkbox"/> OTHER OPTIONS |
| L – Leads (std) | H – Hall Effect (std) | E – Encoder |
| C – Connector | R – Resolver | G – Gearhead |
| M – MS connector | S – Sensorless | |

BN42 IP65 Typical Outline

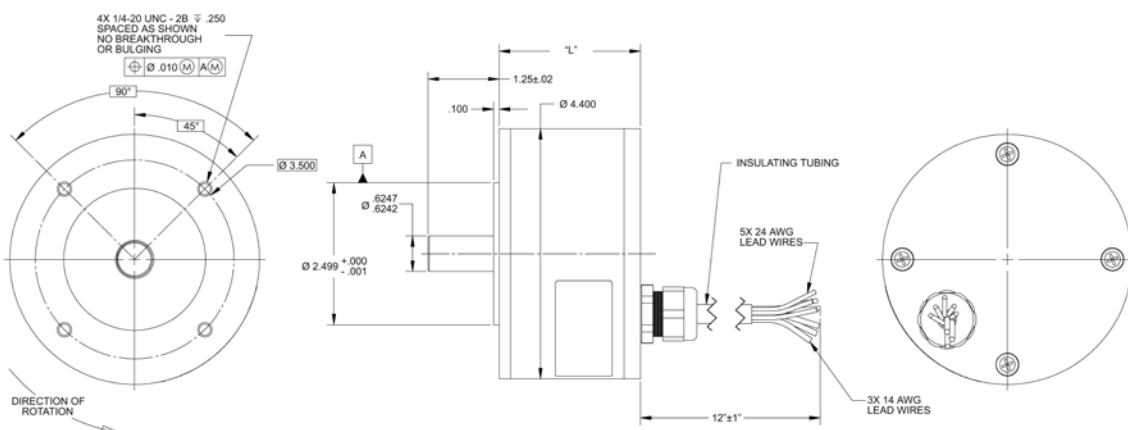

Termination Table

PIN COLOR	CONNECTION
YELLOW	V _{CC}
GRAY	GROUND
RED	A COIL
BLACK	B COIL
GREEN	C COIL
BLUE	S2 OUT
BROWN	S1 OUT
ORANGE	S3 OUT

Dimensions are in inches

Note: An optional 4.15 (105.4) square front end cap is available.

BN42 IP65 Performance Curves

BN42 IP65 Performance Curves

BN42-23IP-01: Continuous & Intermittent Operation at 24 Volt DC

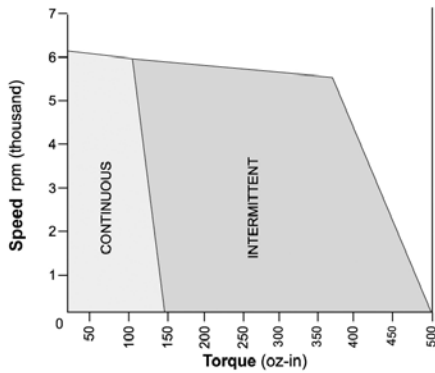

BN42-23IP-02: Continuous & Intermittent Operation at 50 Volt DC

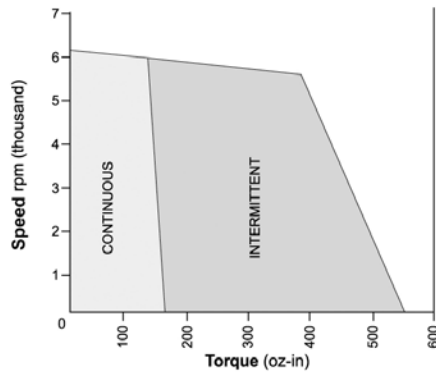

BN42-23IP-03: Continuous & Intermittent Operation at 100 Volt DC

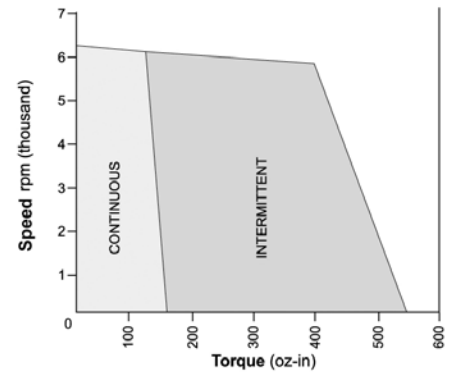

BN42-33IP-01: Continuous & Intermittent Operation at 24 Volt DC

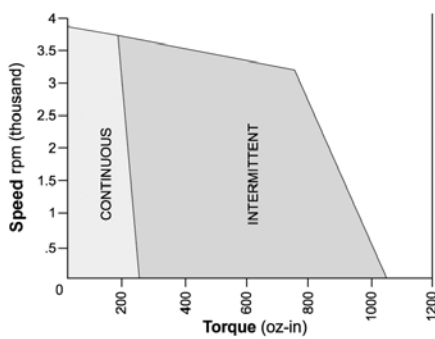

BN42-33IP-02: Continuous & Intermittent Operation at 50 Volt DC

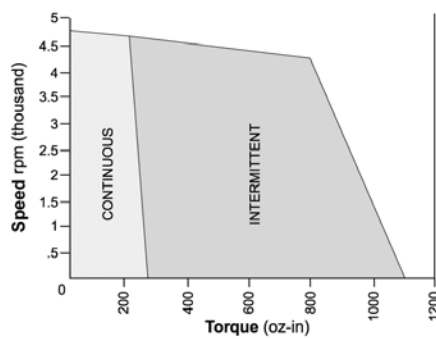

BN42-33IP-03: Continuous & Intermittent Operation at 100 Volt DC

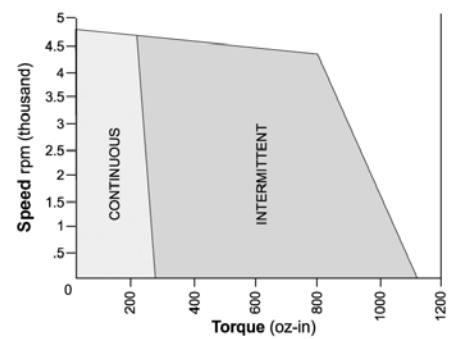

BN42-43IP-01: Continuous & Intermittent Operation at 24 Volt DC

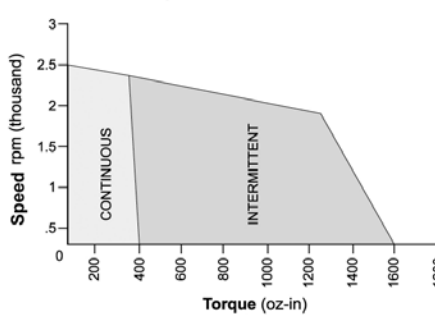

BN42-43IP-02: Continuous & Intermittent Operation at 50 Volt DC

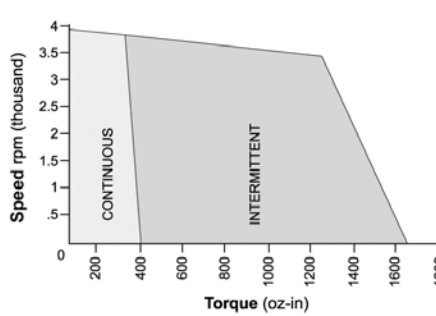

BN42-43IP-03: Continuous & Intermittent Operation at 100 Volt DC

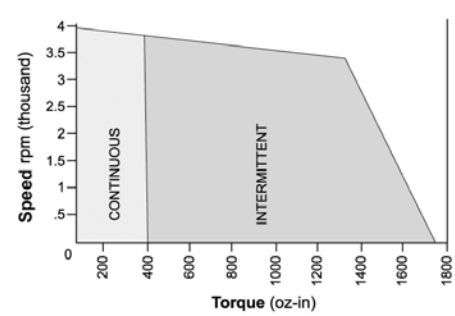

BN42-53IP-01: Continuous & Intermittent Operation at 24 Volt DC

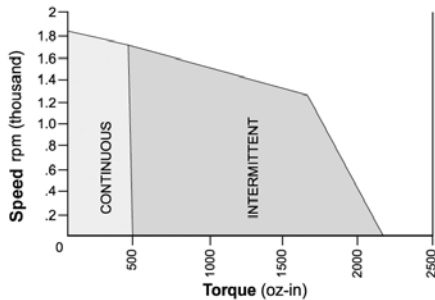

BN42-53IP-02: Continuous & Intermittent Operation at 50 Volt DC

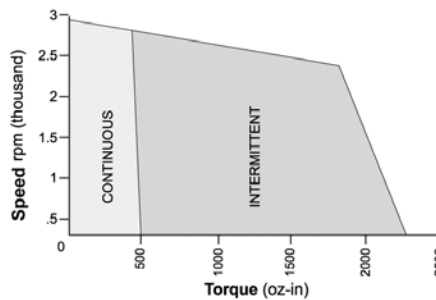

BN42-53IP-03: Continuous & Intermittent Operation at 100 Volt DC

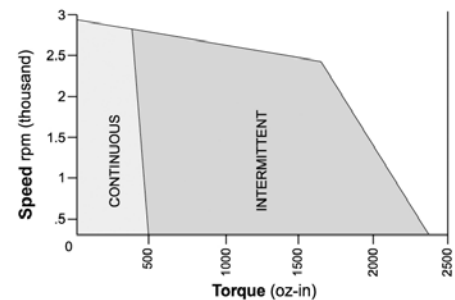

Note: Intermittent operation is based on a 20% duty cycle of one minute on, four minutes off. Please contact the factory regarding the duty cycle of your application.